

AGENDA
SAN ELIJO JOINT POWERS AUTHORITY
MONDAY NOVEMBER 9, 2015 AT 9:00 AM
SAN ELIJO WATER RECLAMATION FACILITY – CONFERENCE ROOM
2695 MANCHESTER AVENUE
CARDIFF BY THE SEA, CALIFORNIA

1. CALL TO ORDER
2. ROLL CALL
3. PLEDGE OF ALLEGIANCE
4. ORAL COMMUNICATIONS (NON-ACTION ITEM)
5. PRESENTATION OF AWARDS
None
6. * **CONSENT CALENDAR**
7. * APPROVAL OF MINUTES FOR THE OCTOBER 12, 2015 MEETING
8. * APPROVAL FOR PAYMENT OF WARRANTS AND MONTHLY INVESTMENT REPORTS
9. * SAN ELIJO WATER RECLAMATION FACILITY TREATED EFFLUENT FLOWS – MONTHLY REPORT
10. * SAN ELIJO JOINT POWERS AUTHORITY RECYCLED WATER PROGRAM – MONTHLY REPORT
11. * ITEMS REMOVED FROM CONSENT CALENDAR

Items on the Consent Calendar are routine matters and there will be no discussion unless an item is removed from the Consent Calendar. Items removed by a "Request to Speak" form from the public will be handled immediately following adoption of the Consent Calendar. Items removed by a Board Member will be handled as directed by the Board.

REGULAR AGENDA

12. COLIFORM STUDY REPORT ACCEPTANCE
 1. Accept and file the Trussell Technologies Coliform Study Report; and
 2. Discuss and take action as appropriate.

Staff Reference: General Manager

13. 2014-15 FINANCIAL AUDIT ACCEPTANCE

1. Accept and file the 2014-15 Fiscal Year Audit for the San Elijo Joint Powers Authority; and
2. Discuss and take action as appropriate.

Staff Reference: Director of Finance and Administration

14. UPDATE ON THE FINAL PROGRAM ENVIRONMENTAL IMPACT REPORT – NORTH SAN DIEGO REGIONAL RECYCLED WATER PROJECT

No action required. This memorandum is submitted for information only.

Staff Reference: General Manager

15. CAPITAL IMPROVEMENT PROJECT – PRELIMINARY TREATMENT UPGRADES

1. Accept and file the Preliminary Design Report;
2. Approve the Agreement with Dudek for Final Design for an amount not to exceed \$263,522; and
3. Discuss and take action as appropriate.

Staff Reference: General Manager

16. VILLAGE PARK RECYCLED WATER PROJECT UPDATE

No action required. This memorandum is submitted for information only.

Staff Reference: General Manager

17. GENERAL MANAGER'S REPORT

Informational report by the General Manager on items not requiring Board action.

18. GENERAL COUNSEL'S REPORT

Informational report by the General Counsel on items not requiring Board action.

19. BOARD MEMBER COMMENTS

This item is placed on the agenda to allow individual Board Members to briefly convey information to the Board or public, or to request staff to place a matter on a future agenda and/or report back on any matter. There is no discussion or action taken on comments by Board Members.

20. CLOSED SESSION

None

A closed session may be held at any time during this meeting of the San Elijo Joint Powers Authority for the purposes of discussing potential or pending litigation or other appropriate matters pursuant to the "Ralph M. Brown Act".

21. ADJOURNMENT

The next regularly scheduled San Elijo Joint Powers Authority Board Meeting will be Monday, December 14, 2015 at 9:00 a.m.

NOTICE:

The San Elijo Joint Powers Authority's open and public meetings meet the protections and prohibitions contained in Section 202 of the Americans With Disabilities Act of 1990 (42 U.S.C Section 12132), and the federal rules and regulations adopted in implementation thereof. Any person with a disability who requires a modification or accommodation, including auxiliary aids or services, in order to participate in a public meeting of the SEJPA Board of Directors may request such modification or accommodation from Michael T. Thornton, General Manager, (760) 753-6203 ext. 72.

The agenda package and materials related to an agenda item submitted after the packet's distribution to the Board is available for public review in the lobby of the SEJPA Administrative Office during normal business hours. Agendas and minutes are available at www.sejpa.org. The SEJPA Board meetings are held on the second Monday of the month, except August.

AFFIDAVIT OF POSTING

I, Michael T. Thornton, Secretary of the San Elijo Joint Powers Authority, hereby certify that I posted, or have caused to be posted, a copy of the foregoing agenda in the following locations:

San Elijo Water Reclamation Facility, 2695 Manchester Avenue, Cardiff, California
City of Encinitas, 505 South Vulcan Avenue, Encinitas, California
City of Solana Beach, 635 South Highway 101, Solana Beach, California

The notice was posted at least 72 hours prior to the meeting, in accordance with Government Code Section 54954.2(a).

Date: November 4, 2015



Michael T. Thornton, P.E.
Secretary / General Manager

SAN ELIJO JOINT POWERS AUTHORITY
MINUTES OF THE BOARD MEETING
HELD ON OCTOBER 12, 2015
AT THE
SAN ELIJO WATER RECLAMATION FACILITY

David Zito, Chair

Catherine S. Blakespear, Vice Chair

A meeting of the Board of Directors of the San Elijo Joint Powers Authority (SEJPA) was held Monday, October 12, 2015, at 9:00 a.m., at the San Elijo Water Reclamation Facility at 2695 Manchester Avenue, Cardiff by the Sea, California.

1. CALL TO ORDER

Chair Zito called the meeting to order at 9:02 a.m.

2. ROLL CALL

Directors Present:

Catherine S. Blakespear
Ginger Marshall
Mark Muir
David Zito

Directors Absent:

None

Others Present:

General Manager
Director of Operations
Director of Finance & Administration
Administrative Assistant/Board Clerk

Michael Thornton
Christopher Trees
Paul Kinkel
Jennifer Basco

SEJPA Counsel:

Procopio, Cory, Hargreaves & Savitch

Adriana Ochoa

City of Solana Beach

City Manager
Director of Engineering/Public Works

Greg Wade
Mohammad "Mo" Sammak

City of Encinitas:

Director of Engineering and Public Works
Public Works Management Analyst

Glenn Pruum
Bill Wilson

3. PLEDGE OF ALLEGIANCE

Chair Zito led the Pledge of Allegiance.

4. ORAL COMMUNICATIONS

None

5. PRESENTATION OF AWARDS

Chair Zito recognized General Manager Michael Thornton for 15 years of service to the agency.

6. CONSENT CALENDAR

Moved by Board Member Muir and seconded by Board Member Marshall to approve the Consent Calendar.

Motion carried with unanimous vote of approval.

Consent Calendar:

Agenda Item No. 7	Approval of Minutes for the September 14, 2015 meeting
Agenda Item No. 8	Approval for Payment of Warrants and Monthly Investment Report
Agenda Item No. 9	San Elijo Water Reclamation Facility Treated Effluent Flows – Monthly Report
Agenda Item No. 10	San Elijo Joint Powers Authority Recycled Water Program – Monthly Report
Agenda Item No. 11	Acceptance of Completion – Construction Contract for the San Elijo Water Reclamation Facility and San Elijo Hills Pump Station Emergency Power Project
Agenda Item No. 12	Acceptance of Completion – Construction Contract for the Shaftless Screw Conveyor Project for the San Elijo Water Reclamation Facility
Agenda Item No. 13	Professional Services Contract for Blower Replacement Project

14. ITEMS REMOVED FROM CONSENT CALENDAR

None

15. CONSOLIDATION EVALUATION REQUEST – SAN ELIJO JOINT POWERS AUTHORITY (SEJPA) AND ENCINA WASTEWATER AUTHORITY (EWA)

General Manager Thornton updated the Board of Directors on the SEJPA/EWA consolidation evaluation request, which was discussed by EWA at the October 6, 2015 member managers meeting. Mr. Thornton stated that there were some concerns expressed at the member managers meeting. Board Member Muir suggested collaborative agreements may be a better first step towards consolidation. The General Manager stated that he will approach EWA again to clarify that the initial step being proposed is with cooperative agreements between the agencies, similar to the Employee

Leasing Agreement, that have the potential for creating win-win results. Staff will examine possible areas of collaboration between the agencies and discuss them with the Board of Directors at a future meeting.

16. BUILDING IMPROVEMENT PROGRAM

General Manager Thornton provided an update and summary of proposed next steps for the building improvement program. He noted that from the last Board meeting, critical items that should be addressed includes seismic deficiencies, site security and access control, improving public and ADA access, eliminate health and safety risks, improving the fire suppression system, and upgrading specific areas including the process control room, IT infrastructure, laboratory, and constructing additional office space.

Mr. Thornton stated that staff will focus on being cost conscious and will review the initial conceptual design for areas of cost reductions. Specific attention will be given to addressing the identified code and safety issues. After a brief discussion, all parties agreed that due to the level of deficiencies identified, the Administration Building must be relocated or combined with another option. Mr. Thornton also stated that there could be an opportunity to develop a building design that could provide lease tenant space. He stated that the location of the San Elijo Water Reclamation Facility (SEWRF) is attractive to engineering and water research firms. Mr. Thornton reported that he will examine this option as means of creating revenues to support the building program and reduce the financial impact to the ratepayers. Mr. Thornton also noted that the Caltrans North Corridor Project will likely impact the SEWRF site and can create opportunities for cost sharing site improvements. Two significant topics are the proposed bike path along the west side of the SEWRF property and a new roundabout located on Manchester at the entrance to the SEWRF. Staff is working with the Caltrans' project team to create win-win solutions for both agencies.

17. SAN ELIJO JOINT POWERS AUTHORITY END OF YEAR REVIEW OF THE FISCAL YEAR 2014-15 FINANCIAL STATEMENT EXPENSES

Paul Kinkel, Director of Finance and Administration provided a financial review for Fiscal Year 2014-15. Overall, the SEJPA was below budget by \$154,806 or 2.9% for all programs. Wastewater Treatment, Pump Stations, Ocean Outfall, and Storm Water programs were under budget by \$211,800 or 5.0%. The Reclaimed Water program, which is funded through the sale of recycled water, experienced significant sales growth in Fiscal Year 2014-15 and revenues exceeded budget by \$222,116 or 9.6%. The Reclaimed Water program expenses exceeded budget by \$56,994 or 5.1%. SEJPA was also able to proactively pay down CalPERS unfunded pension costs by \$125,000.

No action required. This memorandum was submitted for information only.

18. GENERAL MANAGER'S REPORT

None

19. GENERAL COUNSEL'S REPORT

None

20. BOARD MEMBER COMMENTS

None

21. CLOSED SESSION

None

22. ADJOURNMENT

The meeting adjourned at 9:54 a.m. The next Board of Directors meeting will be held on November 9, 2015.

Respectfully submitted,

A handwritten signature in black ink, appearing to read "M. Thornton", written over a horizontal line.

Michael T. Thornton, P.E.
General Manager

SAN ELIJO JOINT POWERS AUTHORITY**PAYMENT OF WARRANTS****16-11****For the Month of October 2015**

Warrant #	Vendor Name	G/L Account	Warrant Description	Amount
32103	Abcana Industries	Supplies - Chemicals	Hydrochloric Acid	440.39
32104	Advanced Air & Vacuum	Services - Maintenance	Thermal valve and pressure valve	1,547.29
32105	Aire Filter Products	Repair Parts Expense	Filters for aeration blowers	140.80
32106	Anthem Blue Cross EAP	Employee Assistance Program	EAP - 12/01/15 - 06/30/16	322.00
32107	Applied Industrial Tech.	Repair Parts Expense	Spherical rollers, double row ball, and seals	434.27
32108	Arizona Instrument	Services - Maintenance	Recalibration	648.61
32109	ASCE Membership	Dues & Memberships	Membership	275.00
32110	AT&T	Utilities - Telephone	Phone service - 08/13/15 - 09/12/15	349.80
32111	AT&T	Utilities - Telephone	DSL - 08/10/15 - 09/09/15	100.38
32112	AT&T	Utilities - Telephone	DSL - 08/20/15 - 09/19/15	100.85
32113	Atlas Pumping Service Inc.	Services - Grease & Scum	Grease and scum pumping, grit and screening	1,297.23
32114	Barracuda Networks, Inc.	Utilities - Internet	Network back-up	50.00
32115	B.J.'s Rental Store	Equipment Rental/Lease	Air compressor	528.00
32116	Marisa Buckles	Subsistence - Travel	Seminar, mileage, and supplies	74.13
32117	City of Solana Beach	Contribution	Return sediment drying pad Capital Contributor	4,681.00
32118	Complete Office	Supplies - Office	Office supplies	175.73
32119	Cummins Cal Pacific, Inc.	Repair Parts Expense	Sender-water temp	24.83
32120	D&H Water Systems	Repair Parts Expense	Peristaltic metering pump	494.40
32121	Del Mar Blue Print	Printing	Converting plans to PDF	17.28
32122	City of Encinitas	Contribution	Return sediment drying pad Capital Contributor	7,022.00
32123	Global Capacity	Utilities - Internet	T-1 Service - September and October	558.54
32124	Guardian	Dental/Vision	Dental - October	2,007.89
32125	Health and Human Resource	Employee Assistance Program	EAP	334.40
32126	Paul Kinkel	Subsistence - Travel	Mileage - meetings	10.36
32127	The Lawton Group	Services - Intern Program	Weeks worked - 09/07/15 - 09/18/15	1,775.57
32128	Leaf & Cole, LLP	Services - Accounting	Audit - progress billing	6,000.00
32129	Liebert Cassidy Whitmore	Seminars/Education	Webinars	120.00
32130	McMaster-Carr Supply Co.	Supplies - Shop & Field	Plumbing and field supplies	1,104.01
32131	Metro Fire & Safety	Services - Maintenance	Sprinklers annual inspection	295.00
32132	NeWest Construction	Services - Construction	Emergency generator	137,826.00
32133	Olin Corp - Chlor Alkali	Supplies - Chemicals	Sodium Hypochlorite	3,110.83
32134	Pacific Green Landscape	Services - Landscape	September	2,975.00
32135	Parada Painting	Services - Contractors	Prep, prime, and paint	10,504.43
32136	Penhall Company	Services - Maintenance	Scanning and coredrill service	815.00
32137	Public Employees - Retirement	Retirement Plan - PERS	Retirement - 09/12/15 - 09/25/15	11,842.88
32138	ReadyRefresh	Supplies - Lab	Kitchen and laboratory supplies	275.32
32139	Rosemount Inc.	Repair Parts Expense	Magnetic flowtube	1,843.04
32140	Santa Fe Irrigation District	Utilities - Water	Recycled water	61.57
32141	San Diego Gas & Electric	Utilities - Gas & Electric	Gas and electric - 08/08/15 - 09/03/15	66,130.37
32142	Sun Life Financial	Life Insurance/Disability	Life and disability insurance - October	1,448.78
32143	Tesco Controls	Service - IT Support	Cyber security	23,345.00
32144	Christopher A. Trees	Fuel	SCCWRP meeting	43.00
32145	Trussell Technologies, Inc.	Services - Engineering	Process engineering, evaluation, coliform study	3,642.00
32146	Unifirst Corporation	Services - Uniforms	Uniform service	187.96
32147	Underground Service Alert/SC	Services - Alarm	Dig alert - September	67.50
32148	Vantagepoint Transfer Agents	EE Deduction Benefits	ICMA - 457	6,157.58
32149	Vantagepoint Transfer Agents	ICMA Retirement	ICMA - 401a	2,871.91
32150	Verizon Wireless	Utilities - Telephone	Cell phone service - 08/08/15 - 09/07/15	805.98
32151	VWR International, Inc.	Supplies - Lab	Lab, shop, and field supplies	1,324.07
32152	WageWorks	Payroll Processing Fees	Administration and compliance fees	128.75
32153	Aflac	EE Deduction Benefits	Aflac - October	1,040.04
32154	Ag Tech, LLC	Services - Biosolids Hauling	Biosolids hauling - September	12,060.00
32155	AT&T	Utilities - Telephone	Phone service - 09/13/15 - 10/12/15	345.62
32156	AT&T	Utilities - Telephone	DSL - 09/10/15 - 10/09/15	100.37
32157	AT&T	Utilities - Telephone	Alarm service	402.58
32158	Atlas Pumping Service Inc.	Services - Grease & Scum	Grease and scum pumping	832.32
32159	BankCard Center	Supplies - Office	Parts, office supplies, and meetings	1,492.20
32160	California Water Technologies	Supplies - Chemicals	Ferric Chloride	4,102.01
32161	Calpers	Retirement Plan - PERS	Calpers	11,906.00
32162	Carlsbad Optical	Supplies - Safety	Safety glasses	150.00
32163	Coast Waste Management, Inc.	Services - Grit & Screenings	Roll-off service	1,240.10

SAN ELIJO JOINT POWERS AUTHORITY**PAYMENT OF WARRANTS****16-11****For the Month of October 2015**

Warrant #	Vendor Name	G/L Account	Warrant Description	Amount
32164	Complete Office	Supplies - Office	Office supplies	222.82
32165	Corodata	Rent	Storage rent - September	99.21
32166	CWEA Membership	Dues & Memberships	Membership	81.00
32167	CWEA Membership	Dues & Memberships	Membership	81.00
32168	CWEA Membership	Dues & Memberships	Membership	164.00
32169	CWEA Membership	Dues & Memberships	Membership	164.00
32170	D&H Water Systems	Services - Maintenance	Motor parts	4,059.19
32171	Dezurik	Repair Parts Expense	Butterfly valve	1,060.09
32172	DMV	Services - Other	Safety records - 07/01/15 - 09/30/15	3.00
32173	Dudek & Associates	Services - Engineering	Preliminary design - Headworks	26,977.55
32174	EDCO Waste & Recycling Service	Utilities - Trash	Trash service - September	235.97
32175	City of Encinitas	Service - IT Support	Admin Network	2,500.00
32176	Endress & Hauser	Repair Parts Expense	Terminal 3-pole	118.75
32177	Forte of San Diego	Services - Janitorial	Janitorial Service	1,000.00
32178	Jose Garcia	Seminars/Education	CWEA prep class	35.00
32179	Harbor Freight	Supplies - Shop & Field	Tools, emery cloth, glove, and shop supplies	383.46
32180	Harrington Industrial Plastics	Repair Parts Expense	Valve ball check	139.66
32181	Hoch Consulting, APC	Services - Engineering	Project engineering and grant support	1,505.00
32182	Emmanuel Hurtado	Various	Reimbursement	193.95
32183	Jennifer Basco	Subsistence - Travel	Mileage and meeting	62.22
32184	Konica Minolta	Services - Maintenance	Copier maintenance service	158.91
32185	Lee Michael Konicke	Subsistence - Travel	Reimbursement, conference meals, and parking	184.65
32186	The Lawton Group	Services - Intern Program	Week worked - 09/21/15 - 09/25/15	1,007.41
32187	McMaster-Carr Supply Co.	Supplies - Shop & Field	Electrical and plumbing supplies	438.15
32188	Olin Corp - Chlor Alkali	Supplies - Chemicals	Sodium Hypochlorite	3,208.57
32189	Olivenhain Municipal Water District	Rent	Pipeline rental payment	4,113.00
32190	Pacific Green Landscape	Services - Landscape	Landscape service - October	2,975.00
32191	Penn Valley Pump Co., Inc.	Repair Parts Expense	Gaskets	1,613.00
32192	P.E.R.S.	Medical Insurance - PERS	Health - November	19,209.69
32193	Public Employees - Retirement	Retirement Plan - PERS	Retirement - 09/26/15 - 10/09/15	11,878.73
32194	Preferred Benefit Insurance	Dental/Vision	Vision - October	301.50
32195	ProBuild Company, LLC	Supplies - Shop & Field	Repair parts, office supplies, and tools	497.55
32196	Process Pump Sale's, Inc.	Repair Parts Expense	Repair kit	380.48
32197	Procopio Cory Hargreaves	Services - Legal	General - September	3,043.75
32198	Rosemount Inc.	Repair Parts Expense	Pressure transmitter	2,490.00
32199	San Dieguito Water District	Utilities - Water	Recycled water	9,023.34
32200	Santa Fe Irrigation District	Utilities - Water	Recycled water	98.07
32201	Santa Fe Irrigation District	SFID Distribution Pipeline	Pipeline purchase payment - September	2,007.23
32202	San Diego Gas & Electric	Utilities - Gas & Electric	Gas and electric - 09/03/15 - 10/05/15	63,694.16
32203	SimplexGrinnell	Supplies - Safety	Fire extinguishers service and parts	2,193.28
32204	Board of Equalization	Accrued Sales Tax Payable	Sales Tax 3rd Qtr - 2015	371.00
32205	Test America	Services - Laboratory	Water sample testing	787.50
32206	Christopher A. Trees	Subsistence - Travel	Mileage - SDCWA	21.33
32207	Unifirst Corporation	Services - Uniforms	Uniform service	303.16
32208	UPS	Postage/Shipping	Mailing parts	126.34
32209	Vantagepoint Transfer Agents	EE Deduction Benefits	ICMA - 457	6,162.93
32210	Vantagepoint Transfer Agents	ICMA Retirement	ICMA - 401a	2,885.55
32211	WEX Bank	Fuel	Fuel	824.20
	San Elijo Payroll Account	Payroll	Payroll - 10/02/15	61,463.38
	San Elijo Payroll Account	Payroll	Payroll - 10/16/15	62,841.50
				<u>\$ 643,397.20</u>

SAN ELIJO JOINT POWERS AUTHORITY

PAYMENT OF WARRANTS SUMMARY

**For the Month of October 2015
As of October 26, 2015**

PAYMENT OF WARRANTS		\$ 643,397.20
Reference Number	16-11	

I hereby certify that the demands listed and covered by warrants are correct and just to the best of my knowledge, and that the money is available in the proper funds to pay these demands. The cash flows of the SEJPA, including the Member Agency commitment in their operating budgets to support the operations of the SEJPA, are expected to be adequate to meet the SEJPA's obligations over the next six months. I also certify that the SEJPA's investment portfolio complies with the SEJPA's investment policy.



Paul F. Kinkel
Director of Finance & Administration

STATEMENT OF FUNDS AVAILABLE FOR PAYMENT OF WARRANTS
AND INVESTMENT INFORMATION
As of October 26, 2015

<u>FUNDS ON DEPOSIT WITH</u>	<u>AMOUNT</u>
 LOCAL AGENCY INVESTMENT FUND <i>(SEPTEMBER 2015 YIELD 0.337%)</i>	
RESTRICTED SRF RESERVE	\$ 630,000.00
UNRESTRICTED DEPOSITS	\$ 6,572,154.01
 CALIFORNIA BANK AND TRUST <i>(OCTOBER 2015 YIELD 0.01%)</i>	
REGULAR CHECKING	\$ 6,623.66
PAYROLL CHECKING	\$ 5,000.00
 TOTAL RESOURCES	 \$ 7,213,777.67

SAN ELIJO JOINT POWERS AUTHORITY
MEMORANDUM

November 9, 2015

TO: Board of Directors
San Elijo Joint Powers Authority

FROM: General Manager

SUBJECT: SAN ELIJO WATER RECLAMATION FACILITY TREATED EFFLUENT FLOWS –
MONTHLY REPORT

RECOMMENDATION

No action required. This memorandum is submitted for information only.

DISCUSSION

Monthly Treatment Plant Performance and Evaluation

Wastewater treatment for the San Elijo Joint Powers Authority (SEJPA) met all NPDES ocean effluent limitation requirements for the month of September 2015. The primary indicators of treatment performance include the removal of Carbonaceous Biochemical Oxygen Demand (CBOD) and Total Suspended Solids (TSS). The SEJPA is required to remove a minimum of 85 percent of the CBOD and TSS from the wastewater. For the month of September, treatment levels for CBOD and TSS were 98.6 and 98.4 percent removal, respectively, (as shown in Figure 1 and Figure 2).

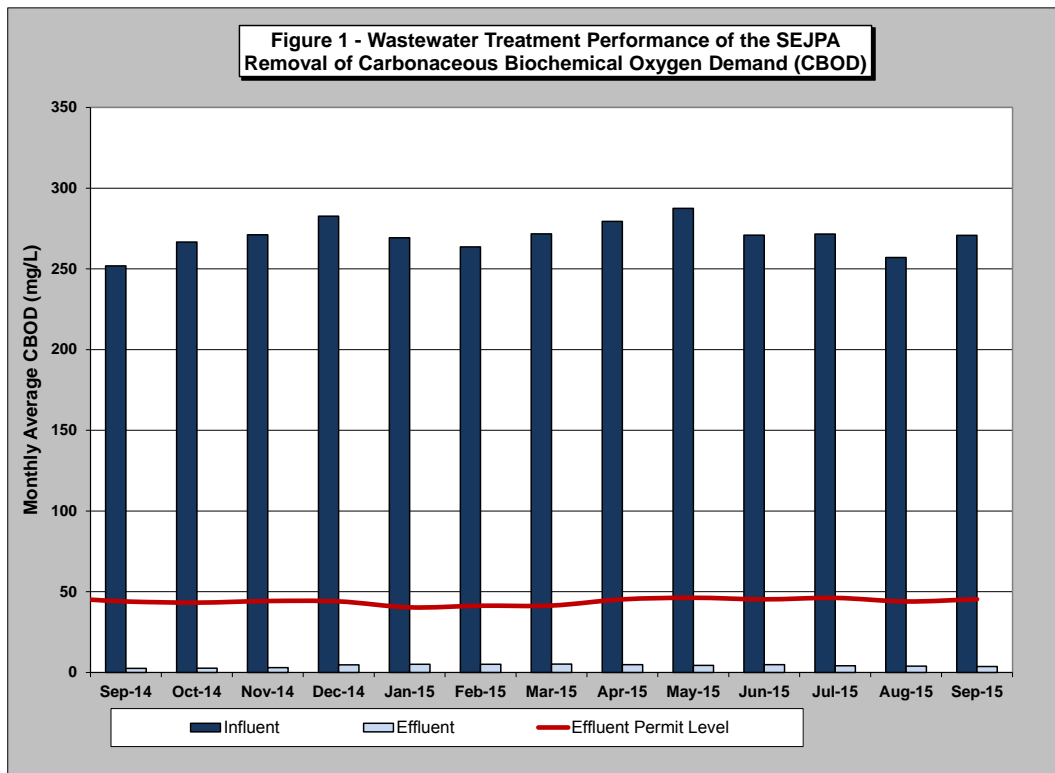

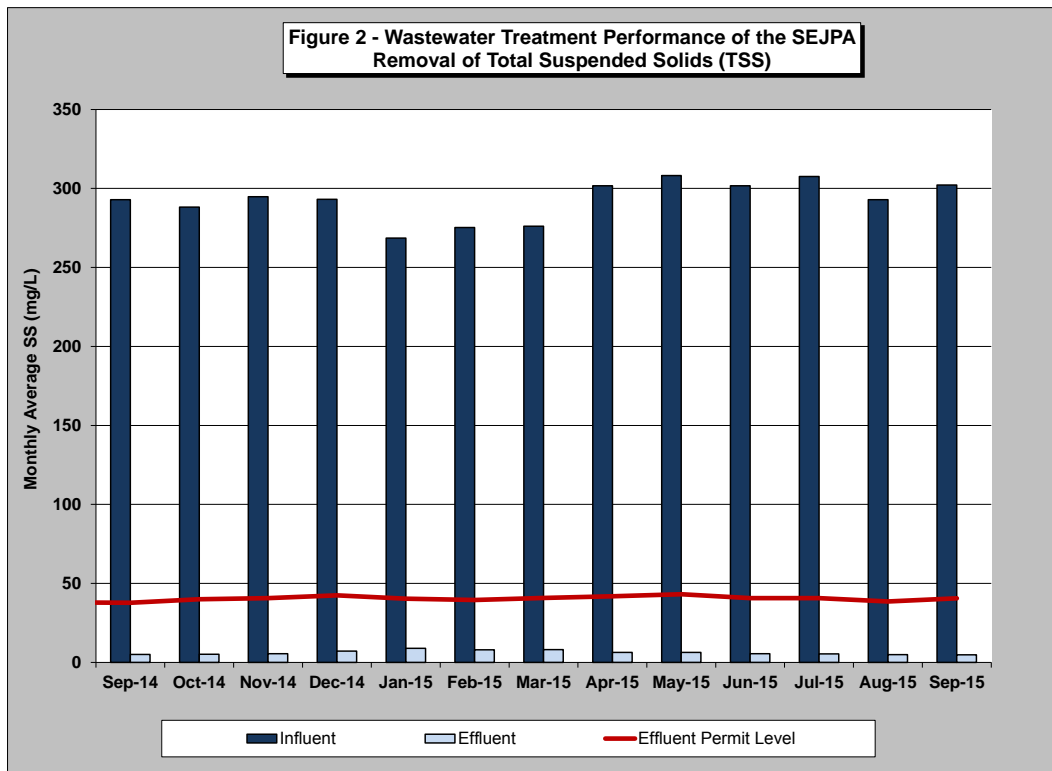

Member Agency Flows

Presented below are the influent and effluent flows for the month of September. Average daily influent flows were recorded for each Member Agency. Total effluent flow was calculated for the San Elijo Water Reclamation Facility.

	September	
	<u>Influent (mgd)</u>	<u>Effluent (mgd)*</u>
Cardiff Sanitary Division	1.256	0.457
City of Solana Beach	1.001	0.364
Rancho Santa Fe SID	0.105	0.038
Total San Elijo WRF Flow	2.362	0.859

* Effluent is calculated by subtracting the recycled water production from the influent wastewater.

Table 1 (next page) presents the historical average, maximum, and unit influent and effluent flow rates per month for each of the Member Agencies during the past 5 years. It also presents the number of connected Equivalent Dwelling Units (EDUs) for each of the Member Agencies during this same time period.

TABLE 1 - SAN ELIJO WATER RECLAMATION FACILITY MONTHLY REPORT - FLOWS AND EDUS

MONTH	AVERAGE DAILY INFLUENT FLOW RATE (MGD)				AVERAGE DAILY EFFLUENT FLOW RATE (MGD)				CONNECTED EDUS				AVERAGE UNIT INFLUENT FLOW RATE (GAL/EDU/DAY)			
	CSD	RSF	SB	TOTAL PLANT	CSD	RSF	SB	TOTAL PLANT	CSD EDUS	RSF EDUS	SB EDUS	TOTAL EDUS	CSD	RSF	SB	TOTAL PLANT
Oct-10	1.413	0.123	1.311	2.847	1.177	0.102	1.092	2.371	8,207	477	7,728	16,412	172	258	170	173
Nov-10	1.399	0.117	1.297	2.813	1.090	0.091	1.011	2.192	8,209	478	7,728	16,415	170	245	168	171
Dec-10	1.605	0.215	1.375	3.195	1.417	0.189	1.214	2.820	8,212	478	7,728	16,418	195	450	178	195
Jan-11	1.452	0.158	1.338	2.948	1.272	0.139	1.172	2.583	8,227	478	7,728	16,433	176	331	173	179
Feb-11	1.413	0.156	1.339	2.908	1.176	0.130	1.114	2.420	8,228	480	7,728	16,436	172	325	173	177
Mar-11	1.387	0.208	1.343	2.938	1.186	0.178	1.148	2.512	8,229	480	7,728	16,437	169	434	174	179
Apr-11	1.320	0.181	1.323	2.824	0.867	0.118	0.869	1.854	8,248	482	7,728	16,458	160	376	171	172
May-11	1.327	0.162	1.320	2.809	0.564	0.069	0.561	1.194	8,248	483	7,728	16,459	161	336	171	171
Jun-11	1.343	0.156	1.390	2.889	0.545	0.063	0.564	1.172	8,249	483	7,728	16,460	163	323	180	176
Jul-11	1.293	0.151	1.430	2.874	0.425	0.050	0.470	0.945	8,250	484	7,728	16,462	157	312	185	175
Aug-11	1.292	0.150	1.405	2.847	0.479	0.056	0.521	1.056	8,252	485	7,728	16,465	157	310	182	173
Sep-11	1.262	0.146	1.333	2.741	0.564	0.066	0.596	1.226	8,254	486	7,728	16,468	153	301	172	166
Oct-11	1.260	0.142	1.303	2.705	0.730	0.082	0.755	1.567	8,260	486	7,728	16,474	153	292	169	164
Nov-11	1.338	0.167	1.307	2.812	1.099	0.137	1.074	2.310	8,261	486	7,728	16,475	162	344	169	171
Dec-11	1.299	0.164	1.305	2.768	1.103	0.139	1.108	2.350	8,264	487	7,728	16,479	157	337	169	168
Jan-12	1.291	0.145	1.303	2.739	1.032	0.116	1.042	2.190	8,266	488	7,728	16,482	160	232	169	166
Feb-12	1.259	0.137	1.283	2.679	1.006	0.109	1.025	2.140	8,268	488	7,728	16,484	152	281	166	163
Mar-12	1.313	0.153	1.255	2.721	0.968	0.113	0.925	2.006	8,269	488	7,728	16,485	159	314	162	165
Apr-12	1.348	0.145	1.209	2.702	0.906	0.097	0.813	1.816	8,278	488	7,728	16,494	163	297	156	164
May-12	1.333	0.150	1.211	2.694	0.577	0.065	0.525	1.167	8,280	488	7,728	16,496	161	308	157	163
Jun-12	1.365	0.143	1.237	2.745	0.547	0.057	0.496	1.100	8,284	489	7,728	16,501	165	293	160	166
Jul-12	1.372	0.126	1.296	2.794	0.457	0.042	0.431	0.930	8,289	489	7,728	16,506	166	258	168	169
Aug-12	1.383	0.128	1.291	2.802	0.473	0.044	0.441	0.958	8,290	490	7,728	16,508	167	261	167	170
Sep-12	1.349	0.142	1.220	2.711	0.544	0.058	0.492	1.094	8,291	490	7,728	16,509	163	290	158	164
Oct-12	1.327	0.123	1.203	2.653	0.678	0.063	0.615	1.356	8,294	490	7,728	16,512	160	251	156	161
Nov-12	1.343	0.128	1.181	2.652	0.862	0.082	0.758	1.702	8,299	490	7,728	16,517	162	261	153	161
Dec-12	1.383	0.141	1.197	2.721	1.261	0.129	1.091	2.481	8,300	490	7,728	16,518	167	288	155	165
Jan-13	1.357	0.145	1.215	2.717	1.155	0.124	1.034	2.313	8,300	490	7,728	16,518	163	296	157	164
Feb-13	1.349	0.138	1.201	2.688	1.048	0.108	0.933	2.089	8,301	490	7,728	16,519	163	282	155	163
Mar-13	1.402	0.154	1.235	2.791	0.905	0.100	0.797	1.802	8,302	493	7,728	16,521	169	314	160	169
Apr-13	1.297	0.124	1.237	2.658	0.531	0.051	0.506	1.088	8,304	493	7,728	16,523	156	253	160	161
May-13	1.339	0.126	1.185	2.650	0.376	0.036	0.333	0.745	8,304	493	7,728	16,525	161	256	153	160
Jun-13	1.341	0.126	1.190	2.657	0.269	0.025	0.239	0.533	8,307	493	7,728	16,528	161	256	154	161
Jul-13	1.366	0.144	1.269	2.779	0.482	0.050	0.448	0.980	8,309	493	7,728	16,530	164	292	164	168
Aug-13	1.342	0.168	1.258	2.768	0.380	0.048	0.356	0.784	8,311	494	7,728	16,533	161	340	163	167
Sep-13	1.343	0.117	1.193	2.653	0.403	0.036	0.358	0.797	8,311	494	7,728	16,533	162	237	154	160
Oct-13	1.319	0.132	1.184	2.635	0.629	0.063	0.565	1.257	8,314	494	7,728	16,536	159	267	153	159
Nov-13	1.348	0.133	1.194	2.675	0.932	0.092	0.826	1.850	8,315	494	7,728	16,537	162	270	155	162
Dec-13	1.341	0.134	1.191	2.666	1.030	0.103	0.915	2.048	8,316	494	7,728	16,538	161	272	154	161
Jan-14	1.322	0.135	1.194	2.651	0.851	0.087	0.768	1.706	8,318	495	7,728	16,541	159	273	155	160
Feb-14	1.314	0.127	1.172	2.613	0.954	0.093	0.851	1.898	8,323	495	7,728	16,546	158	257	152	158
Mar-14	1.339	0.134	1.185	2.658	0.858	0.086	0.760	1.704	8,324	496	7,728	16,548	161	270	153	161
Apr-14	1.326	0.128	1.128	2.582	0.449	0.043	0.382	0.874	8,328	498	7,728	16,554	159	257	146	156
May-14	1.353	0.124	1.127	2.604	0.159	0.015	0.132	0.306	8,333	498	7,728	16,559	162	249	146	157
Jun-14	1.341	0.126	1.188	2.655	0.207	0.020	0.183	0.410	8,333	498	7,728	16,559	161	253	154	160
Jul-14	1.271	0.130	1.307	2.708	0.232	0.024	0.239	0.495	8,338	499	7,728	16,565	152	261	169	163
Aug-14	1.228	0.130	1.298	2.656	0.227	0.024	0.239	0.490	8,345	500	7,728	16,573	147	260	168	160
Sep-14	1.215	0.113	1.232	2.560	0.211	0.019	0.214	0.444	8,351	500	7,728	16,579	145	226	159	154
Oct-14	1.204	0.114	1.198	2.516	0.394	0.038	0.392	0.824	8,353	500	7,728	16,581	144	228	155	152
Nov-14	1.237	0.118	1.198	2.553	0.667	0.063	0.646	1.376	8,354	502	7,728	16,584	148	235	155	154
Dec-14	1.323	0.147	1.229	2.699	1.163	0.129	1.081	2.373	8,355	502	7,728	16,585	158	293	159	163
Jan-15	1.253	0.130	1.232	2.615	0.984	0.102	0.967	2.053	8,359	503	7,977	16,838	150	259	154	155
Feb-15	1.229	0.132	1.228	2.589	0.757	0.081	0.757	1.595	8,361	504	7,977	16,841	147	262	154	154
Mar-15	1.269	0.135	1.231	2.635	0.583	0.062	0.566	1.211	8,365	504	7,977	16,846	152	268	154	156
Apr-15	1.183	0.124	1.196	2.503	0.350	0.036	0.354	0.740	8,366	504	7,977	16,847	141	246	150	149
May-15	1.209	0.117	1.149	2.475	0.545	0.053	0.518	1.116	8,367	505	7,977	16,848	144	232	144	147
Jun-15	1.287	0.113	1.052	2.452	0.362	0.032	0.296	0.690	8,369	506	7,977	16,852	154	224	132	146
Jul-15	1.282	0.110	1.176	2.568	0.392	0.034	0.359	0.785	8,370	510	8,003	16,883	153	216	147	152
Aug-15	1.264	0.095	1.087	2.446	0.315	0.023	0.271	0.609	8,371	510	8,003	16,884	151	186	136	145
Sep-15	1.256	0.105	1.001	2.362	0.457	0.038	0.364	0.859	8,372	511	8,003	16,885	150	206	125	140

CSD: Cardiff Sanitary Division

RSF CSD: Ranch Santa Fe Community Service District

SB: Solana Beach

EDU: Equivalent Dwelling Unit

ASSUMPTIONS: SB average flow includes San Elijo Hills flow of 0.131 mgd

SB Connected EDUs includes 300 EDUs for the City of San Diego

EDU Numbers Revised by Dudek for March and April 2013

Figure 3 (below) presents the 5-year historical average daily flows per month for each Member Agency. This is to provide a historical overview of the average treated flow by each agency. As shown in the figure, the average treated flow has been approximately 2.4 million gallons per day (mgd). Also shown in Figure 3 is the total wastewater treatment capacity of the plant, 5.25 mgd, of which each Member Agency has the right to 2.5 mgd, and Rancho Santa Fe Community Service District leases 0.25 mgd.

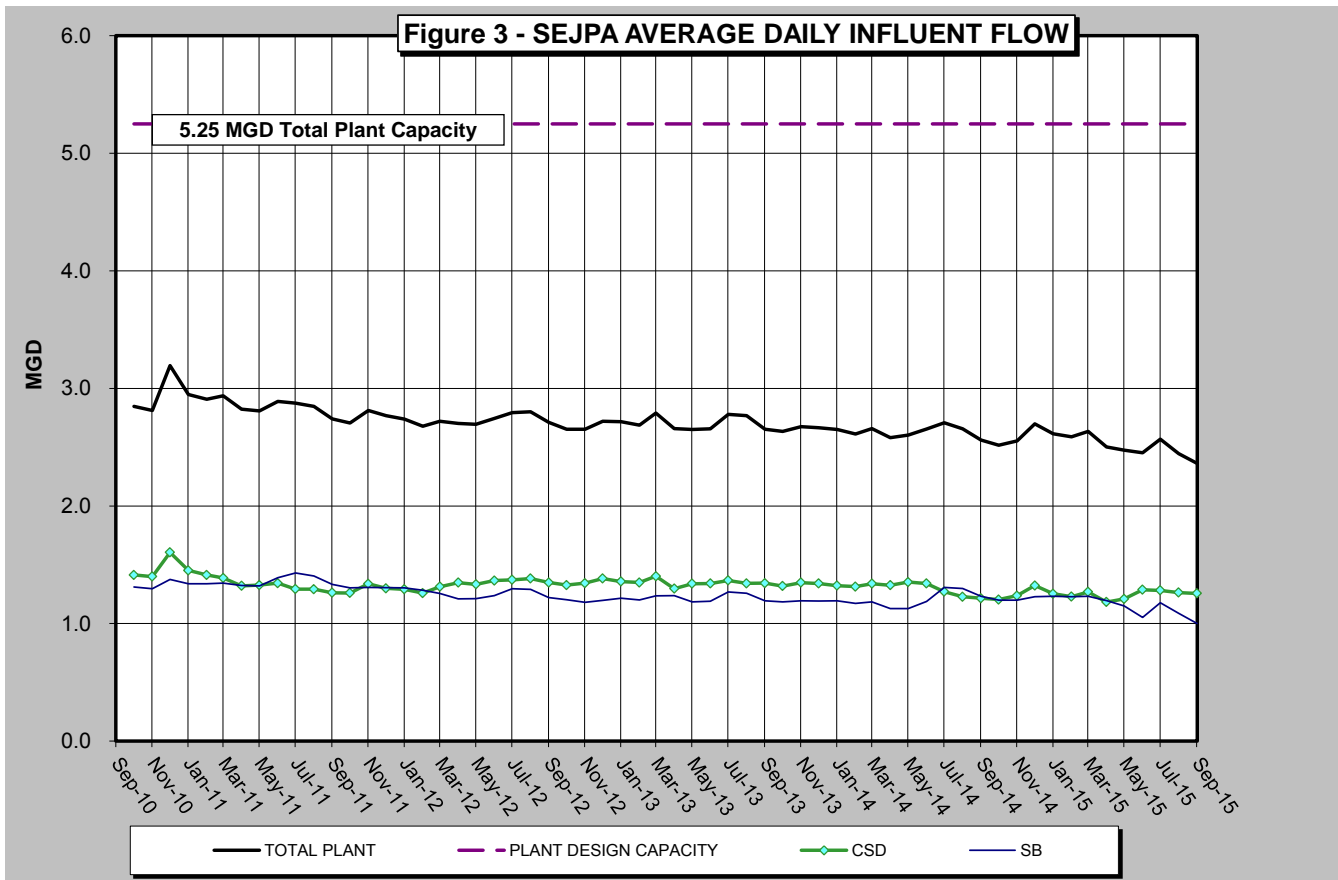

City of Escondido Flows

The average and peak flow rate from the City of Escondido Hale Avenue Resource Recovery Facility, which discharges through the San Elijo Ocean Outfall, is reported below. The following average flow rate and peak flow rate is reported by the City of Escondido for the month of September 2015.

	Flow (mgd)
Escondido (Average flow rate)	7.46
Escondido (Peak flow rate)	19.0

Connected Equivalent Dwelling Units

The City of Solana Beach updated the connected EDUs number that is reported to the SEJPA in July 2015. The City of Encinitas and Rancho Santa Fe CSD report their connected EDUs every month. The number of EDUs connected for each of the Member Agencies is as follows:

	Connected (EDU)
Cardiff Sanitary Division	8,372
Rancho Santa Fe SID	511
City of Solana Beach	7,666
San Diego (to Solana Beach)	337
Total EDUs to System	16,885

Respectfully submitted,



Michael T. Thornton, P.E.
General Manager

*

SAN ELIJO JOINT POWERS AUTHORITY
MEMORANDUM

November 9, 2015

TO: Board of Directors
San Elijo Joint Powers Authority

FROM: General Manager

SUBJECT: SAN ELIJO WATER RECLAMATION PROGRAM – MONTHLY REPORT

RECOMMENDATION

No action required. This memorandum is submitted for information only.

DISCUSSION

Recycled Water Production

For the month of September 2015, recycled water demand was 153.24 acre-feet (AF), which was met using 152.93 AF of recycled water and 0.31 AF of supplementation with potable water. The distribution system was designed to use potable water during peak summer demands. Demand was down from the past three years due to higher than normal rainfall in September 2015.

Figure 1 (attached) provides monthly supply demands for recycled water since September 2000. Figure 2 (attached) provides a graphical view of annual recycled water demand spanning fifteen fiscal years. Figure 3 (attached) shows the monthly recycled water demand for each September since the program began.

Respectfully submitted,



Michael T. Thornton, P.E.
General Manager

Figure 1 - MONTHLY RECYCLED WATER DEMAND

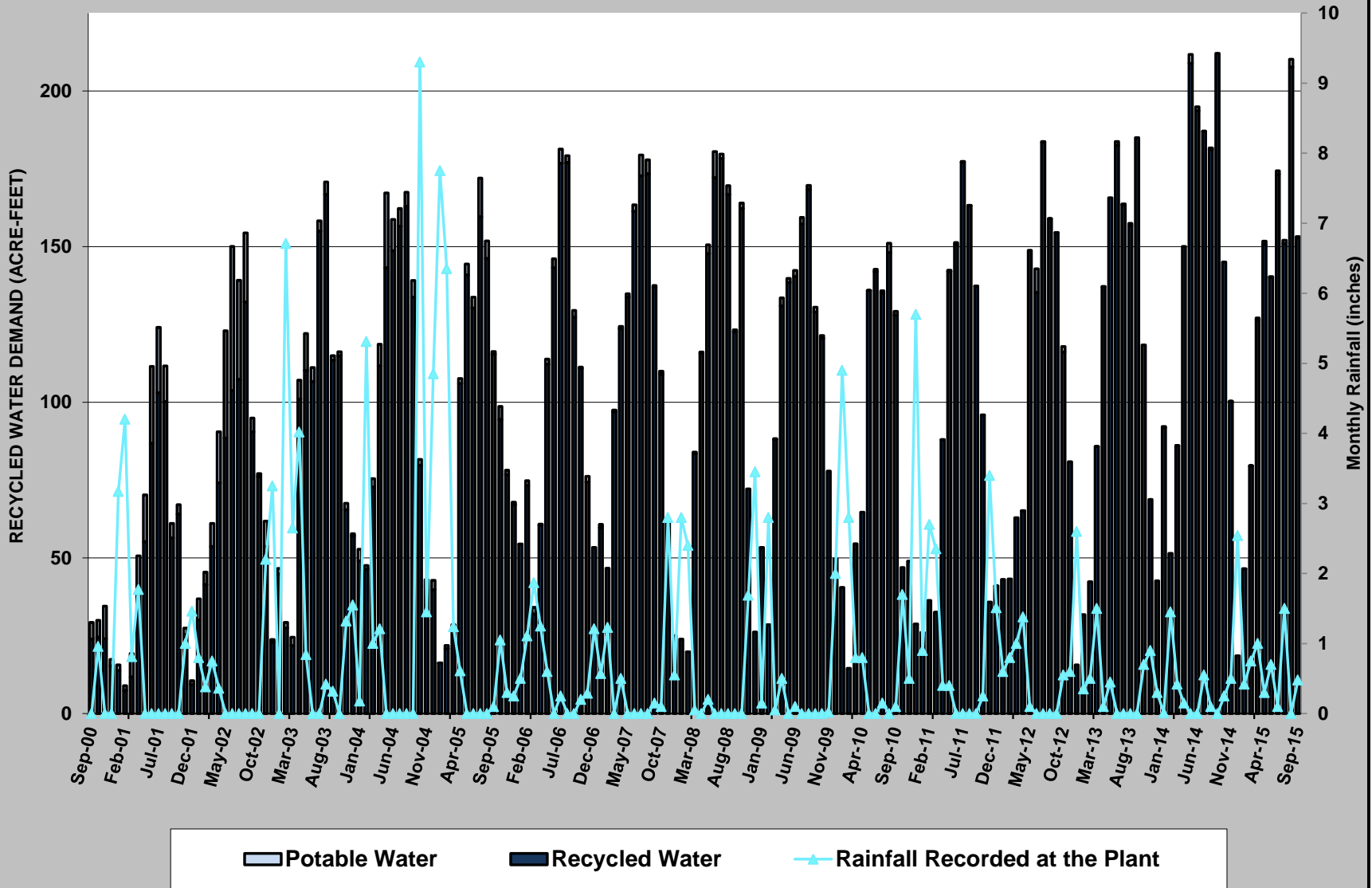

Figure 2 - RECYCLED WATER DEMAND by FISCAL YEAR

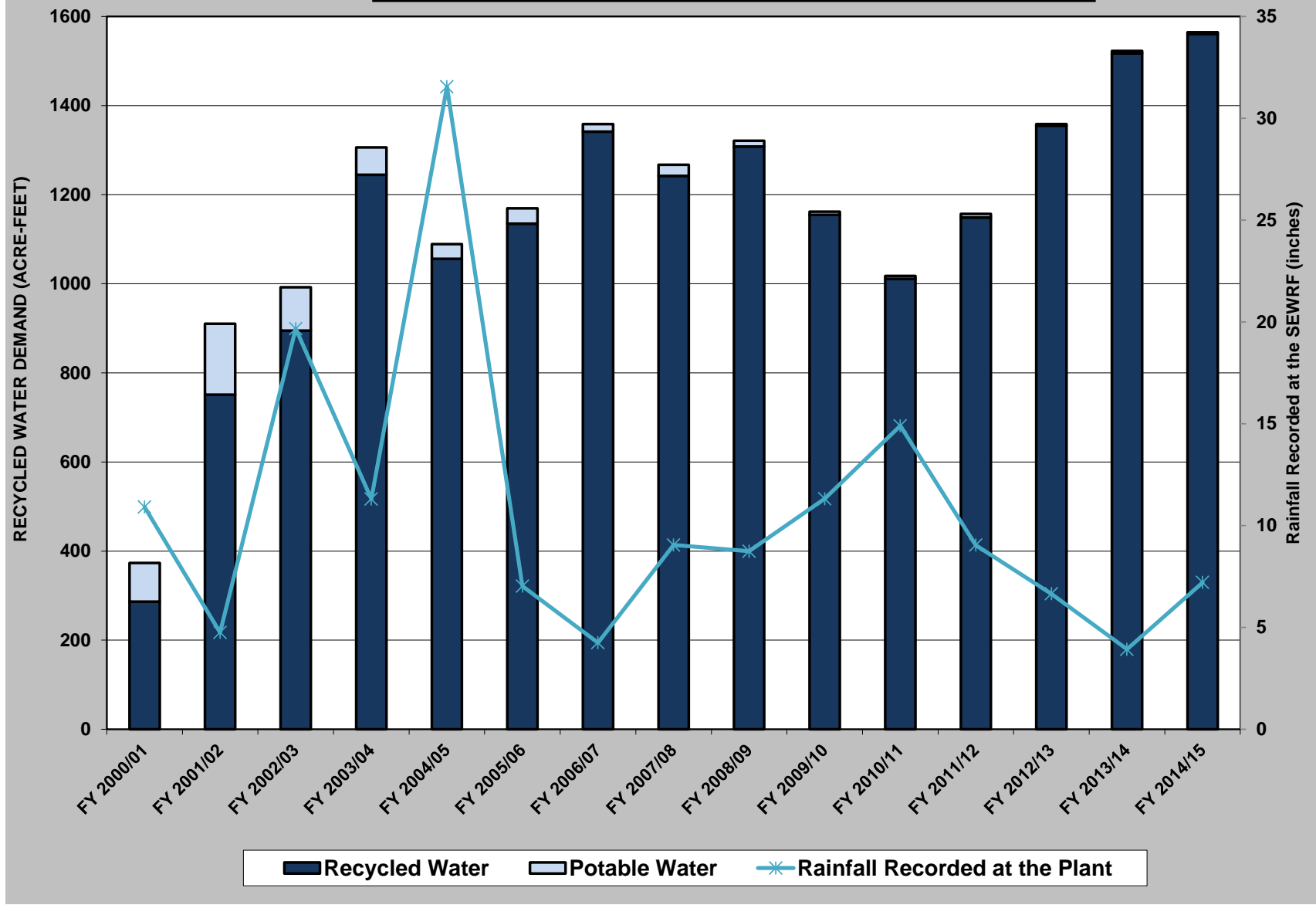
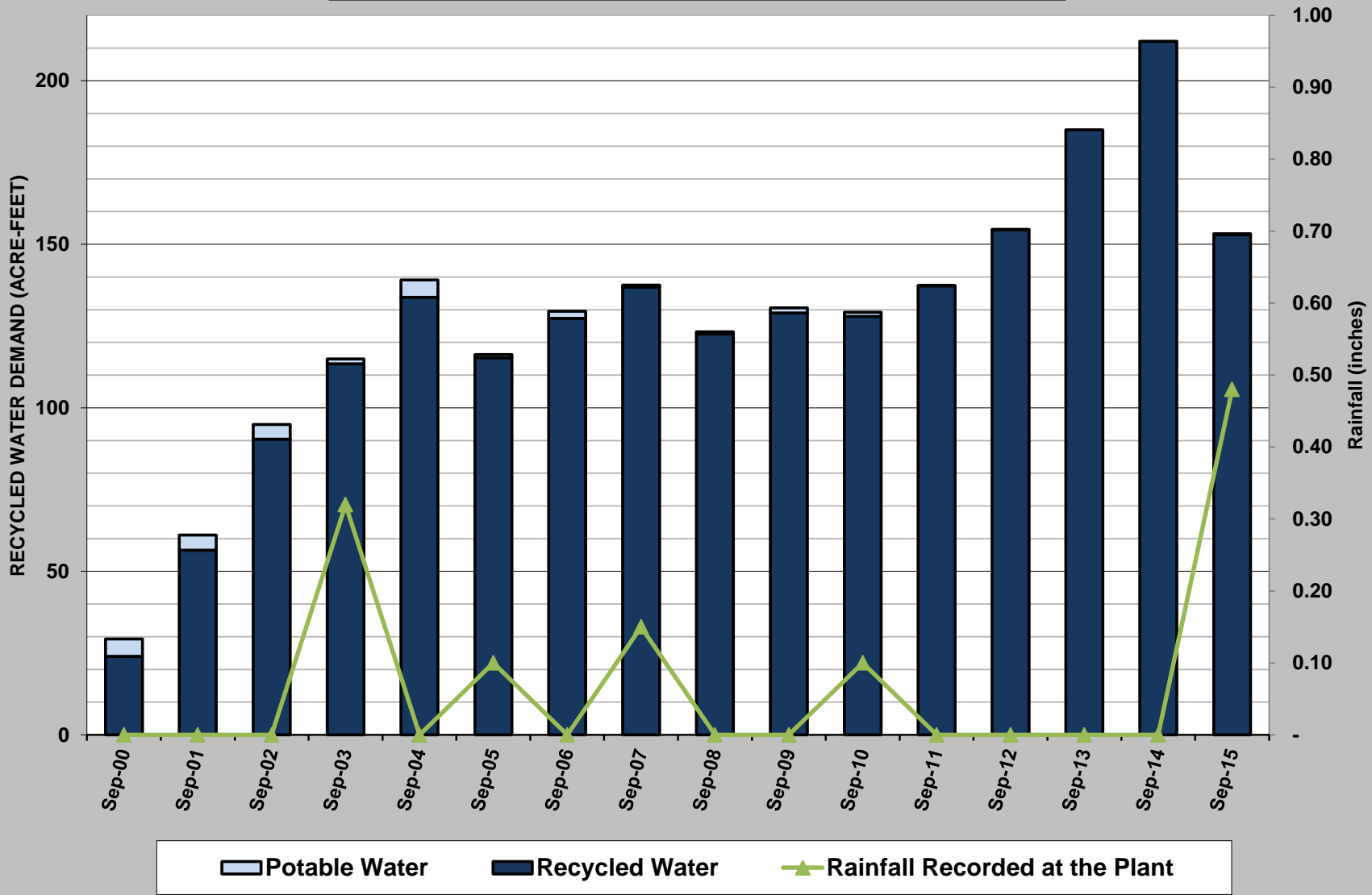

Figure 3 - SEPTEMBER RECYCLED WATER DEMAND



SAN ELIJO JOINT POWERS AUTHORITY
MEMORANDUM

November 9, 2015

TO: Board of Directors
San Elijo Joint Powers Authority

FROM: General Manager

SUBJECT: COLIFORM STUDY REPORT ACCEPTANCE

RECOMMENDATION

It is recommended that the Board of Directors:

1. Accept and file the Trussell Technologies Coliform Study Report; and
2. Discuss and take action as appropriate.

BACKGROUND

The San Elijo Joint Powers Authority owns and operates a 3.02 MGD capacity recycled water treatment and delivery system in accordance with the California Regional Water Quality Control Board, San Diego Region Order No. 2000-010, as amended. This treatment process was installed in the year 2000 and includes granular media filters (GMF) and a chlorine contact tank for filtration and disinfection. A side-stream process of microfiltration and reverse osmosis (MF/RO) was installed in 2013 to reduce salinity in the recycled water and produce a better quality product. The SEJPA is required to collect samples of the recycled water on a daily basis and analyze the samples for total coliform bacteria. Since the system began operation, sample results have shown occasional total coliform results above the acceptable limits.

When the MF/RO system began operation in 2013, the frequency of high total coliform results increased. Staff investigated, and identified multiple issues that likely contributed to the high coliform. Several actions were implemented and noticeable improvements were achieved. However, the complete elimination of the problem was not obtained. In March 2014, Trussell Technologies was retained by the SEJPA to review the tertiary treatment process and water quality data, and to provide conclusions and recommendations.

Trussell reviewed several years of water quality data, developed a test plan, and performed fieldwork to execute the test plan. A technical memorandum was prepared summarizing the results. In April 2015, sand filter operations likely caused three exceedances within a 30-day period and the information was reported to the Regional Board in the monthly report. On October 13, 2015 the RWQCB issued a Staff Enforcement Letter to the SEJPA relating to

coliform exceedances in November 2014 and April 2015, and a minimum contact time calculation issue in July 2015.

DISCUSSION

Since March 2014, the SEJPA has been working with Dr. Shane Trussell and his firm Trussell Technologies to investigate and eliminate sporadic coliform issues associated with the recycled water treatment process. The random nature of the total coliform exceedances has made it difficult to determine the cause, and has required a lengthy analysis to determine the effectiveness of actions taken. Staff has been able to decrease the coliform frequency back to what has historically been seen in the process. However, staff is determined to find the cause and eliminate the problem. The results of this investigation are outlined in the attached technical memorandum.

The memorandum identifies two probable causes of the increased total coliform: (1) particle shielding as a result of biological activity within the GMF and (2) possible sample contamination from the sample location or technique. Based on these findings, Trussell Technologies has recommended three operational changes and two long-term capital projects.

The operational changes include (1) increased manual cleaning of the GMF, (2) reduced acceleration and deceleration of flow rates through the GMF, and (3) changes to the sample location to help eliminate false positive results. These recommendations are being implemented.

The recommended long-term capital projects include replacing the GMF with membrane filtration and adding recycled water storage at the treatment facility. Membrane filtration is a substantially superior filtration process compared to GMF. This recommendation would eliminate the problem through the use of a more advanced treatment technology. The second recommendation, the construction of on-site recycled water storage, separates treatment production from distribution demands. The current recycled water treatment system requires water production to occur in concert with system demands. This places strain on the treatment system as it must increase and decrease production throughout the day. Adding storage between the treatment process and the distribution pumps would greatly reduce treatment strain and would create a more reliable treatment and distribution system.

FINANCIAL IMPACT

There is no financial impact associated with accepting and filing this report. Evaluation of the long-term recommendations will be incorporated into future planning documents for the recycled water system.

It is therefore recommended that the Board of Directors:

1. Accept and file the Trussell Technologies Coliform Study Report; and
2. Discuss and take action as appropriate.

Respectfully submitted,

A handwritten signature in black ink, appearing to read 'M. Thornton', written over a horizontal line.

Michael T. Thornton, PE
General Manager

Attachment: Technical Memorandum from Trussell Technologies dated October 23, 2015, Recommended Actions to Address Coliform Issues at the San Elijo Water Reclamation Facility.



TECHNICAL MEMORANDUM

San Elijo Joint Powers Authority

Draft Date: July 27, 2015

Final Date: October 23, 2015

Authors: Brett Faulkner
Yan Qu, Ph.D.
Shane Trussell, Ph.D., P.E., BCEE

Reviewed by: Christopher Trees, P.E., Director of Operations, SEJPA
Michael Thornton, P.E., General Manager, SEJPA

Subject: **Recommended Actions to Address Coliform Issues at the San Elijo Water Reclamation Facility**

Executive Summary

The San Elijo Water Reclamation Facility (SEWRF) has been experiencing issues with occasional total coliform detections in recycled water post-filtration and chlorine disinfection. Although historical positive coliform detections have occurred in the past, the occasions were rare and the frequency increased in 2013. The increase in the number of coliform detections coincides with the SEWRF expansion to include an advanced water purification facility (AWPF) to produce an additional 0.5 MGD of desalinated recycled water for non-potable purposes. The AWPF treats secondary effluent with Pall microfiltration (MF) membranes followed by reverse osmosis (RO) membranes before blending the 0.5 MGD of RO water with 2.48 MGD of filtered secondary effluent for chlorine disinfection. The AWPF was commissioned in 2013 and has been in operation since then. Since the AWPF operates at a constant production rate, the conventional Dynsand filter was programmed to automatically vary the filtration rate as necessary to meet Title 22 demands. It was determined that rapid changes in sand filter flows through 2013 and part of 2014 contributed significantly to the coliform detections. Programming changes were made in 2014 and coliform detections were greatly reduced. However, occasional coliform detections remain an issue that SEWRF seeks to address. To that end, this Technical Memorandum presents a summary of the data reviewed from the full-scale plant as well as bench-scale work that was performed to provide insight on the likely causes of the coliform detections and develop recommendations.



Two plausible causes were identified as a result of this work:

- Particle shielding as a result of biological activity in the sand filters
- Contamination of samples from the sample line and/or sampling technique

Based on these findings, the following recommendations have been developed to minimize the probability of future coliform violations:

- *Increase the frequency of manual cleanings of the granular media filters* – In lieu of annual cleanings, a routine cleaning schedule is recommended such that one filter is cleaned each month. With four (4) filters in service, this means that each filter will be cleaned three times a year. The cleaning procedure should follow the manufacturer's recommendations. It is also recommended that each filter be chlorinated on an annual basis with an overnight soak at approximately 2000 mg/L as Cl₂.
- *Decrease tertiary pump ramp speed* – In 2013 with the addition of the advanced water treatment system, the flow through the tertiary filters became much more variable in order to match recycled water demands and contributed to increased coliform events in 2013. In 2014 limiting the ramp speed for the pumps to a maximum change of 1 gpm/second decreased surging and as a result decreased coliform events. Further reducing the ramp speed to 0.5 gpm/second, or lower if possible, will further reduce hydraulic surging through the filters that can exacerbate sloughing and particle shielding events.
- *Collect coliform compliance grab sample directly from the effluent weir* – Historically, a sample pump that delivers water for the effluent chlorine analyzer for the chlorine contact basin has been used for sample collection. It is recommended that an autoclaved bottle be used to directly collect this sample from the effluent weir to avoid any possible contamination or false positives. It is also recommended that the sample only be collected when water is flowing over the weir, or when the recycled water system is in production.

The following long-term capital projects should be evaluated to eliminate the coliform issues:

- Replace the continuously backwashing filters with a membrane filtration system (micro- or ultrafiltration) to filter out the coliform and eliminate the potential for particles that could provide a coliform shielding environment.
- Provide on-site recycled water storage to alleviate the hydraulic variability of the tertiary process that is driven by the recycled water demand. Currently SEWRF has limited recycled water storage, which puts pressure on the tertiary facilities to respond quickly in order to meet recycled water demands. The 2015 facilities plan describes the conversion of an existing on-site flow equalization basins that is currently used for primary effluent flow equalization to become a recycled water storage/equalization basin.



1 - BACKGROUND

The SEWRF is located in Cardiff by the Sea, California and is owned and operated by the San Elijo Joint Powers Authority (SEJPA). The SEWRF is permitted to produce up to 3.0 million gallons per day (MGD) of tertiary treated wastewater in compliance with the California Department of Public Health Title 22 Code of Regulations for recycled water users and discharge up to 5.25 MGD of secondary treated wastewater in compliance with their Environmental Protection Agency's (EPA) National Pollutant Discharge Elimination System (NPDES) permit to the Pacific Ocean via an ocean outfall. The recycled water treatment train includes primary sedimentation, secondary aeration and clarification, filtration, and chlorine disinfection. Up to 2.5 MGD of recycled water is filtered with granular media filters (GMF), and as of 2013, an additional 0.5 MGD can be filtered with microfiltration (MF) and reverse osmosis (RO) to reduce the recycled water salinity. After the filtration process, up to 0.5 MGD from the AWPf is combined with the GMF filtrate at the entrance to the chlorine contact basin for chlorine disinfection, which is a rapid mix chamber.

The permits for the SEWRF do not require that nitrogen compounds be removed so biological nitrogen removal is not performed. To prevent nitrification, the SEJPA operates the SEWRF at a low solids retention time (SRT) of ~ 1 to 2 days and ammonia is always present at significant concentrations in the secondary effluent (35 to 45 mg/L). As a result, the addition of sodium hypochlorite for chlorine disinfection in the recycled water facility produces chloramines that serve as the disinfectant. Recycled water demands vary throughout the year ranging from 1.5 MGD in the summer to 0.6 MGD in the winter, but instantaneous flow rates through the tertiary treatment can vary from 0.8 to 3.0 MGD throughout the day. Secondary effluent flows in excess of the recycled water demands are discharged directly to the ocean via outfall. Figures 1 and 2 present 10 days worth of plant influent, equalized primary effluent, and granular media influent flow rates that are representative of summer and winter conditions, respectively. In the winter, when recycled water demands are low, a minimum flow of 600 gpm is maintained through the granular media filters to prevent septicity and upsets.

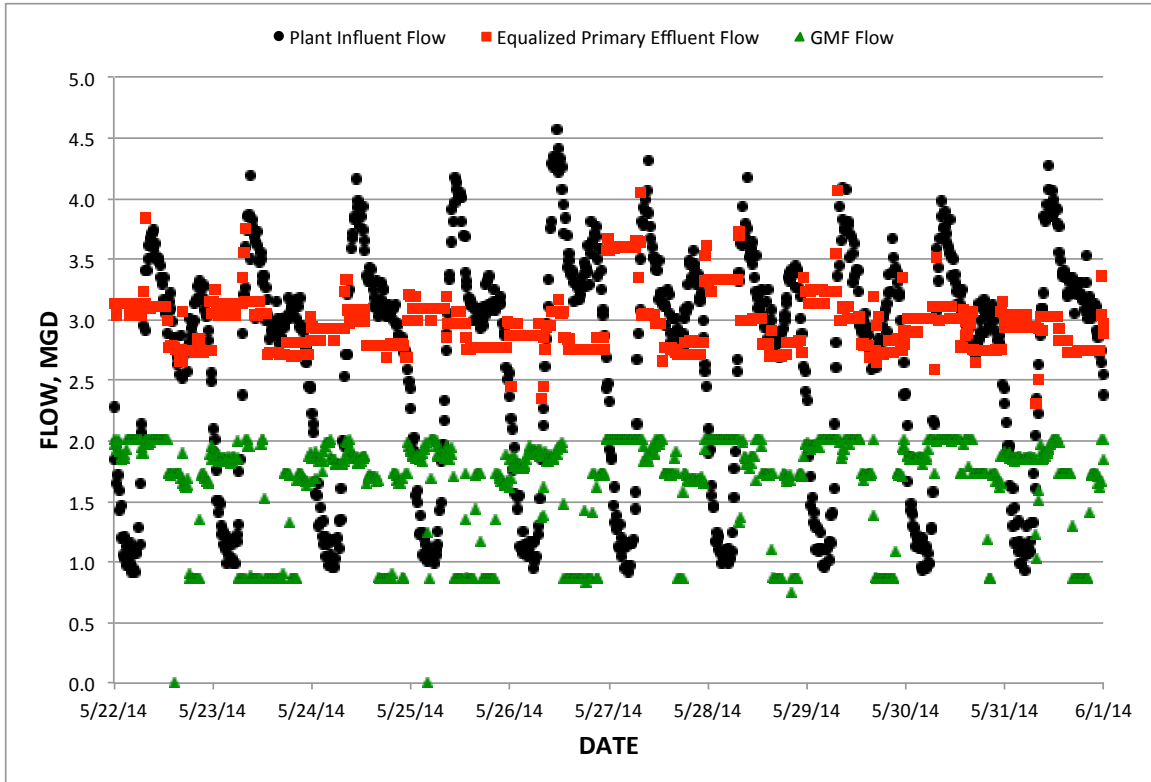

Figure 1 - GMF production rate for ten days in summer at the SEWRF

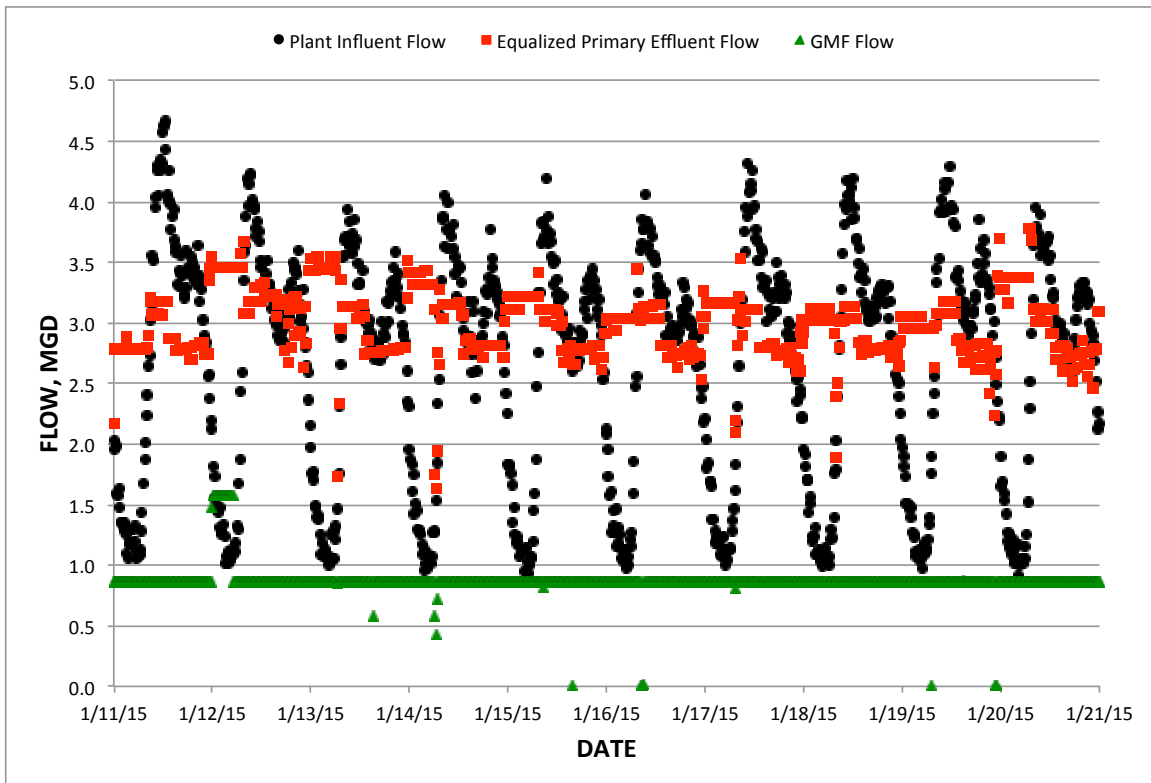

Figure 2 - GMF production rate for ten days in winter at the SEWRF



SEWRF has been experiencing issues with occasional total coliform detections in recycled water post-filtration and chlorine disinfection. Figure 3 presents a probability plot of the daily coliform data for the past six years, beginning in January 2009. Since the majority of samples are non-detect coliform concentrations of <2 MPN/100mL, Figure 3 is focused on the rare occurrences where total coliform was quantified. With the exception of 2013, 99% of the samples collected to date have coliform concentrations less than 23 MPN/100mL. However, the coliform data reveals that there have been coliform detections every year at a concentration greater than 50 MPN/100mL. The 2015 dataset was excluded from this figure since it is incomplete, but there have been positive coliforms recorded in 2015.

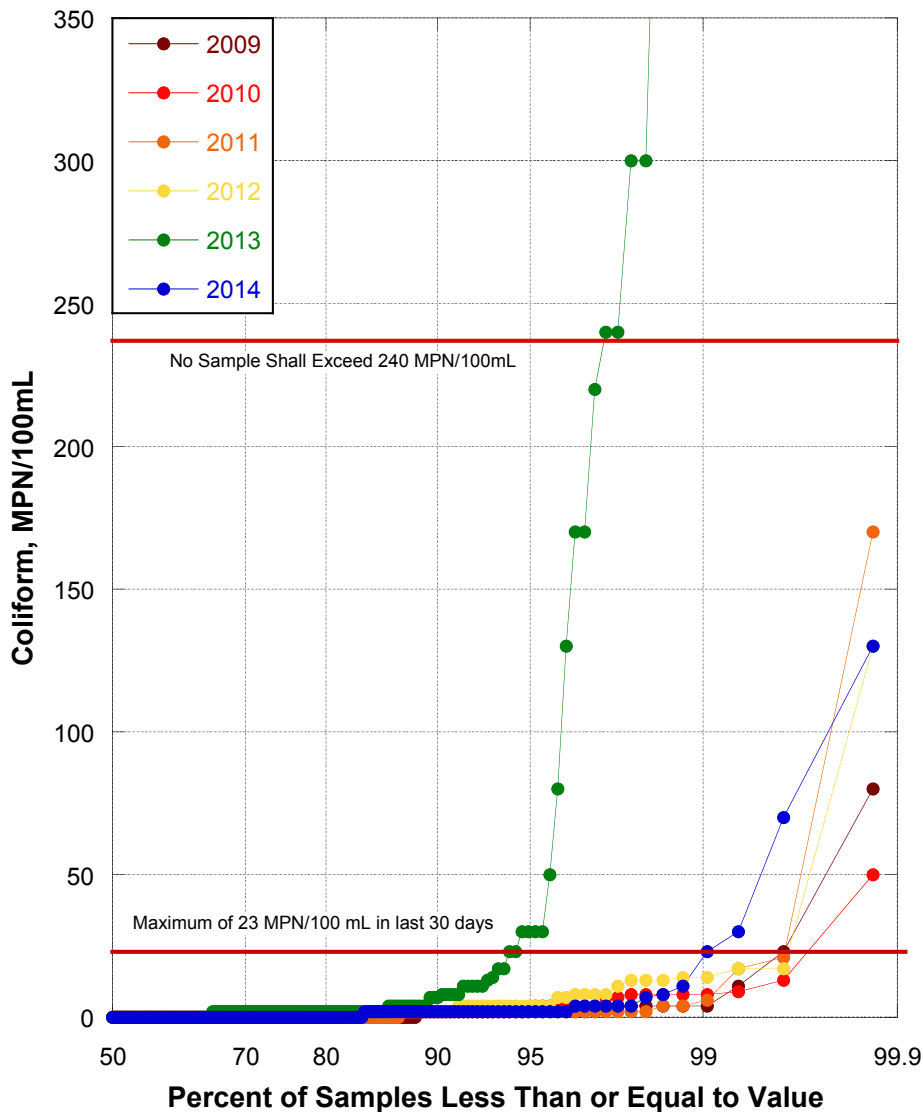

Figure 3 – SEWRF Daily Total Coliform Data from 2008 to 2015

Figure 4 presents probability plots of daily secondary effluent and granular media filter effluent turbidity data since July 2008. The turbidity data shows that the



secondary process has steadily improved over the past seven years, while the filter effluent turbidity has remained consistent. Figure 4 also shows that the filter effluent turbidity always meets the Title 22 turbidity requirement. It is evident from this data that deterioration in secondary effluent or filtered effluent quality is not the root cause of any coliform detections observed at the SEWRF.

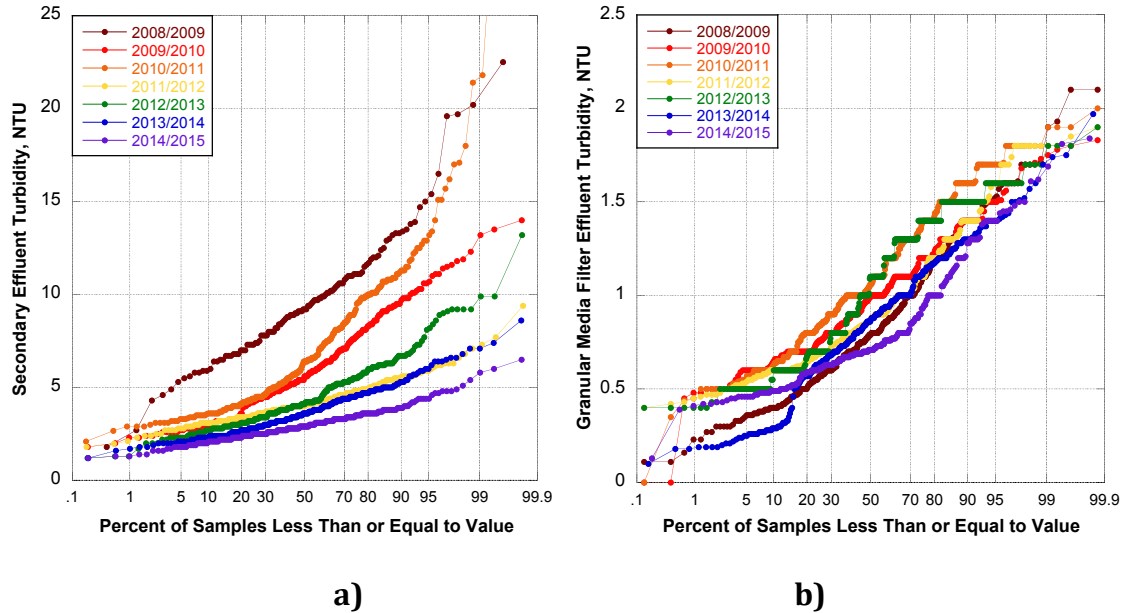

Figure 4 – a) Historical Secondary Effluent Turbidity Data, b) Historical Filter Effluent Turbidity Data

Figures 5 and 6 present the chlorine concentration x time (CT) provided by the disinfection system that highlights the significant CT provided for the recycled water produced at the SEWRF. These data highlight that adequate CT is provided on a consistent basis and it is unlikely that increasing the chlorine residual would improve the frequency of coliform detections. In fact, the winter CT value often exceed the maximum recorded value of 2000 mg*min/L due to lower flow rates.

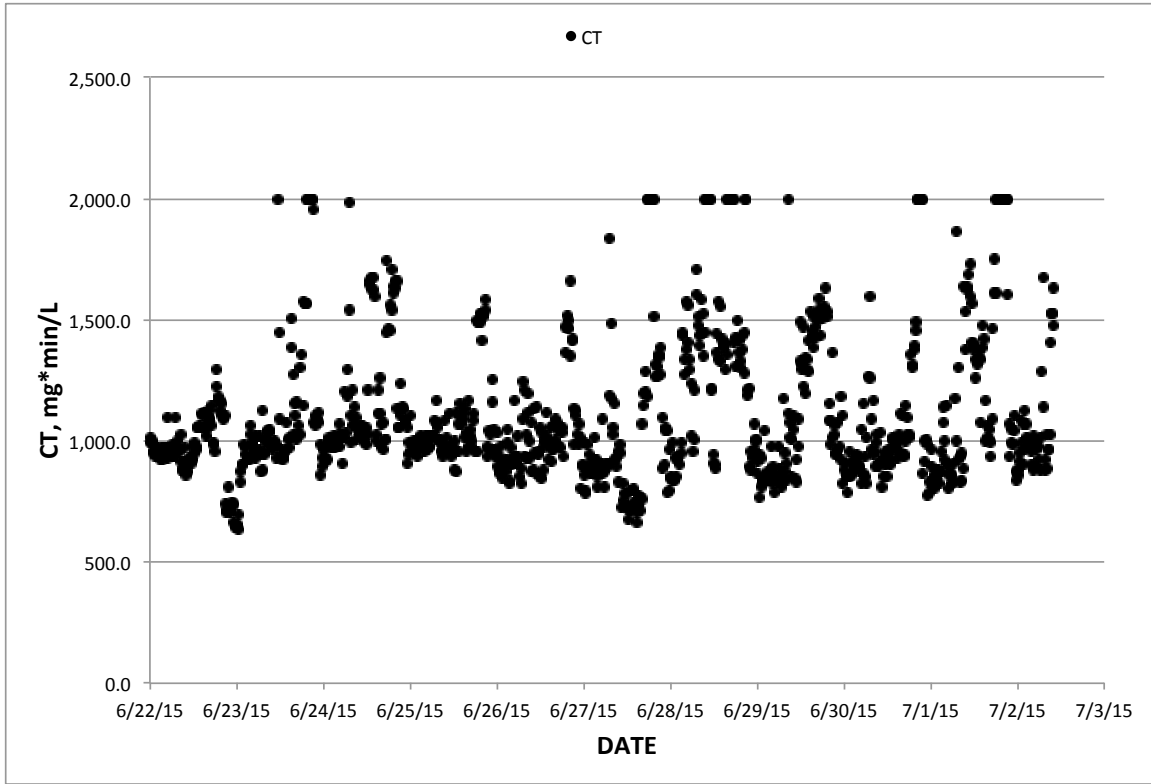

Figure 5 – Summer chlorine concentration x time (CT) for 10 days at the SEWRF

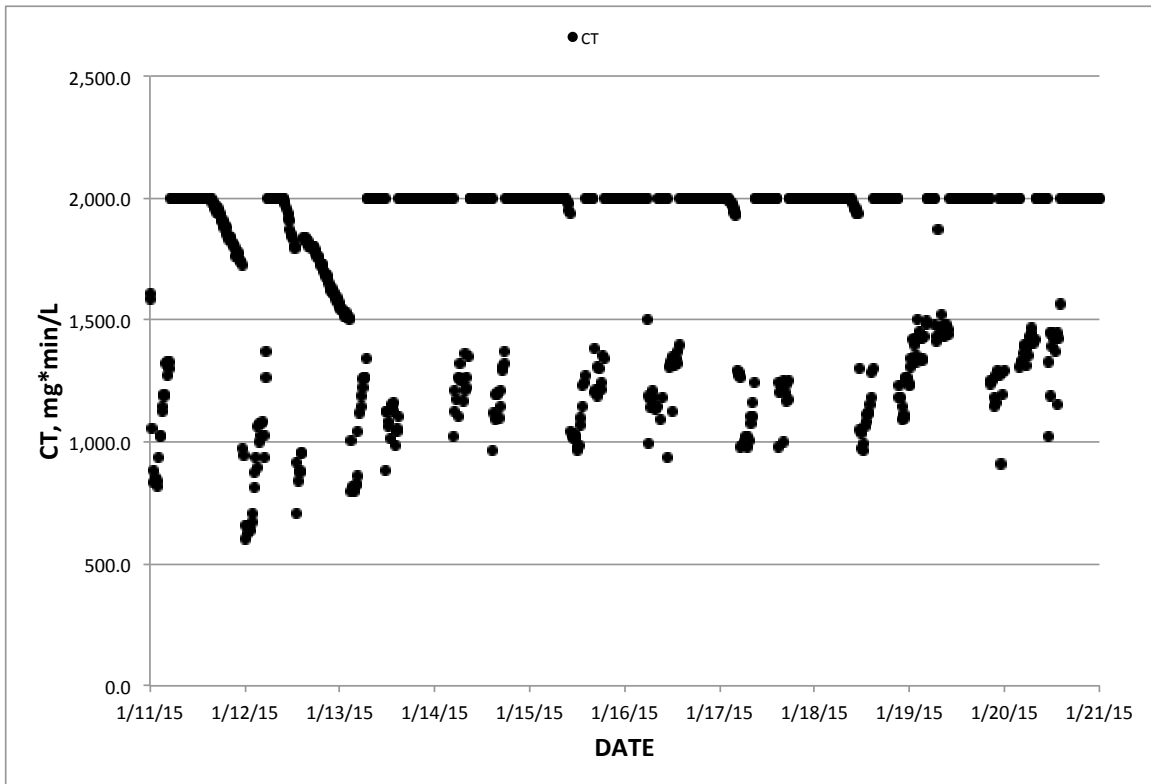

Figure 6 – Winter chlorine concentration x time (CT) for 10 days at the SEWRF

2 - DYNASAND FILTERS

Four Dynasand filters treat non-nitrified secondary effluent at the SEWRF. The granular media filters (GMF) are an up-flow, 36 inch deep filter with continuous backwash. The filter media is cleaned by an internal washing system that scours and cleans a small stream of media from the bottom of the filter bed and redistributes the clean media on the top of the media bed (see Figure 7). The continuous backwashing of the media bed allows for continuous operation and significantly reduces the infrastructure required for filter backwashing and washwater management. Unfortunately, this filter design also allows bio-growth to occur in the media bed in a manner similar to a trickling filter. Table 1 presents the design conditions and flow rates for these filters per design and typical operation. The SEWRF filters have historically been cleaned annually with an air lance to break up and flush the media bed of the accumulated bio-growth and solids that were not effectively removed by the continuous backwashing. The most recent cleanings were performed in October 2014, January 2015 and February 2015.

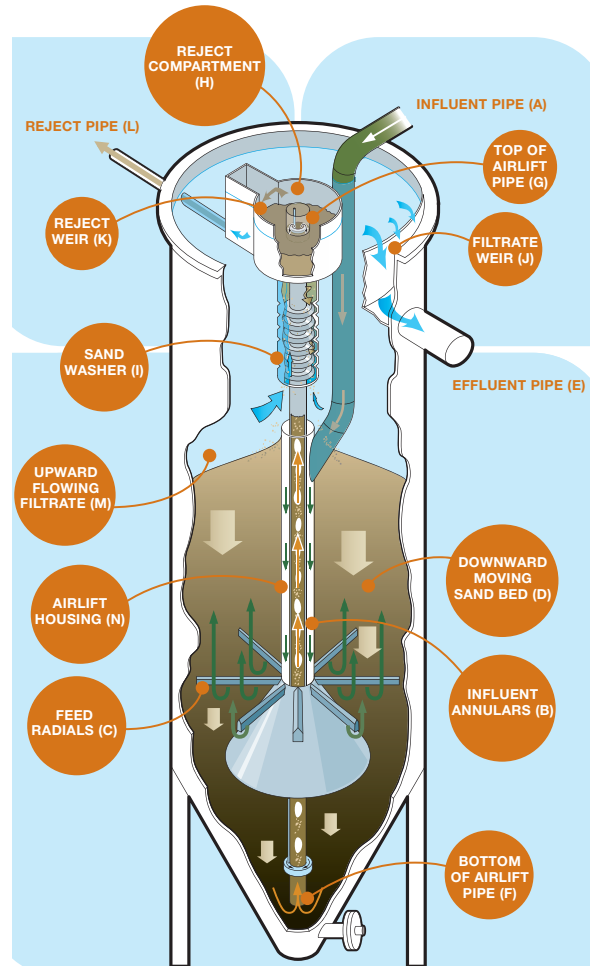

Figure 7 – Illustration of continuous backwash Dynasand® filter flow

Table 1: Filter Design Criteria and Operating Conditions

Parameter	Units	Current	Design
Number of Filters	#	4	
Number of Modules per Filter	#	2	
Area per Module	ft ²	50	
Total Filter Area	ft ²	400	
Media Depth	inches	36	
Media Material	-	sand	
Media Effective Size	-	0.9	
Flow	MGD	1.6	2.88
Filtration Rate	gpm/ft ²	2.8	5.0

Trussell Technologies made a site visit on January 24, 2015 to observe and gather information on the operation, maintenance, and cleaning of the Dynasand filters. During the site visit, significant biological growth was observed in filtrate from the Dynasand filters and this is presented in Figure 8. Operations staff was completing a manual clean of the filters to remove accumulated solids and biological growth from the filter bed. The staged cleanings of the filters allows the biological growth to be observed and documented (see Figure 8). It is recommended that the manual filter cleaning frequency be increased from annually to three times per year. At this frequency, one of four filters will be manually cleaned each month. SEWRF staff has implemented this new cleaning frequency and procedure in February 2015.



Figure 8 – Biogrowth observed on filtrate pipes from three Dynasand filters at the SEWRF: Filter 3 after 1 week of operation (left), Filter 2 after 2 weeks of operation (center), Filter 1 after 8 weeks of operation (right)

The Dynasand filter’s biological nature can produce colloidal particles that shield coliform from chlorine disinfection. The majority of the time this colloidal material is negligible, but biofilms can go through periods of sloughing, in which colloidal particles are released. With colloidal or particulate solids present, coliform can be protected from the chlorine residual and pass through the chlorine contact basin



unharmful (i.e., particle shielding). Also, the colloidal solids do not significantly increase turbidity so it is difficult to determine when these particulates are released.

3 - ALUM AND POLYMER USE

Aluminum sulfate (alum) and polymer are used directly upstream of the filters to enhance filtration and improve filter effluent turbidity. Similar to biological activity, chemical coagulation can form particles that shield coliform from disinfection (i.e., cause particle shielding). The alum and polymer dosing strategy and control logic was changed in June 2011 to automatically dose chemical based on the filter effluent turbidity¹. This resulted in significant reductions in alum and polymer use (see Figure 9) and the realization that much of the time alum and/or polymer is not necessary to enhance filtration due to the improvements in the secondary process performance (see Figure 4a). Beginning in February 2015, a constant minimum dose of alum is applied as required by Title 22 regulations to serve a new cooling tower recycled water customer.

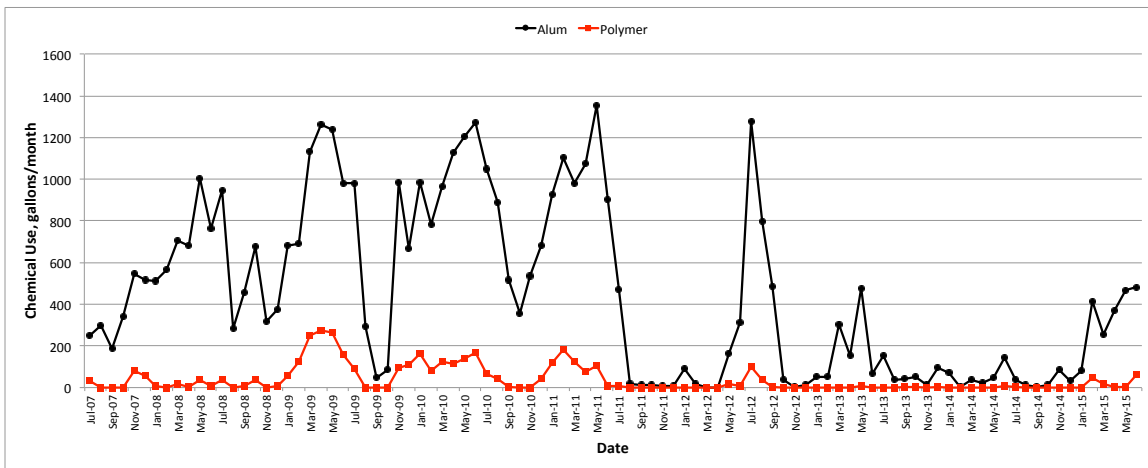

Figure 9 – Historical Monthly Alum and Polymer Use

Figure 10 presents the historical coliform data since the summer of 2008. A comparison of Figures 9 and 10 provides evidence that the coliform events are not correlated to higher alum or polymer use. Chemical addition is a frequent cause of particle shielding that leads to positive coliform detections, but this data suggests that chemical particle shielding is not the cause of the coliform detections at the SEWRF.

¹ Prior to June 2011 the operator would manually set the alum and polymer pump speed twice per day.

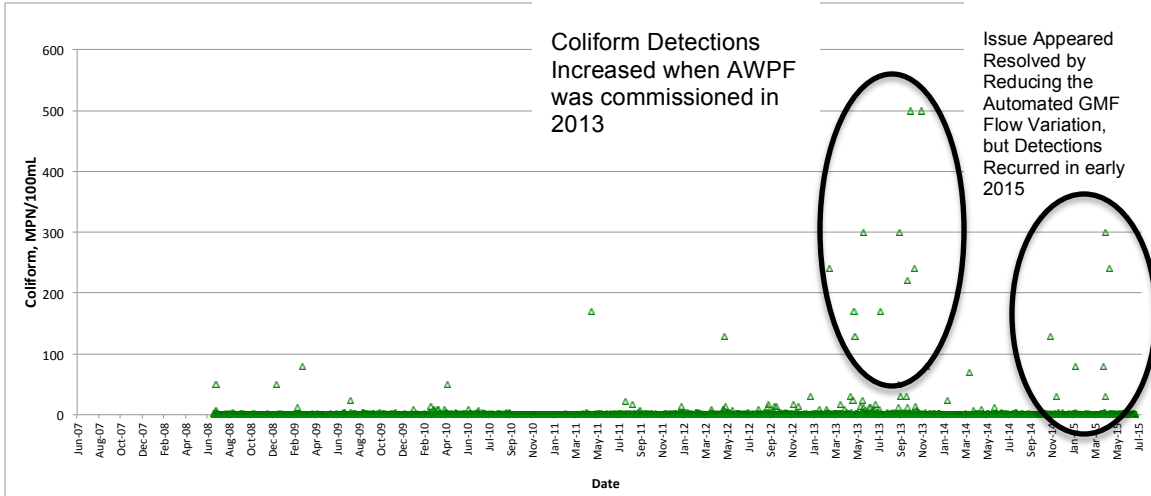

Figure 10 – Historical Daily Coliform Data

In 2013, the flow through the tertiary filters became more variable and rapid changes to the flow set point were made to make up the difference between the constant AWPF output and recycled water demands. The rapid changes to the flow setpoint contributed to the coliform events that were observed in 2013 (Figure 10). In early 2014, the ramp speed for the tertiary pumps was re-programmed to gradually transition the flow setpoint and the reduction in coliform detections was notable. Although the issue has not been completely resolved, the experience confirms that particle shielded coliform are being released with changes in flow.

Figures 11 and 12 present filtration rates as well as filter influent and effluent turbidity data from representative weeks in April and June 2015, respectively. On 4/3/15, 4/4/15, 4/5/15, 4/6/15, and 4/7/15 there were positive coliform concentrations of 4, 4, 2, 300, and 30 MPN/100mL respectively, resulting in a violation. The approximate sample collection time (assumed to be 9:30) is also presented in Figure 11 along with the laboratory determination of whether the sample was positive for coliform or non-detect.

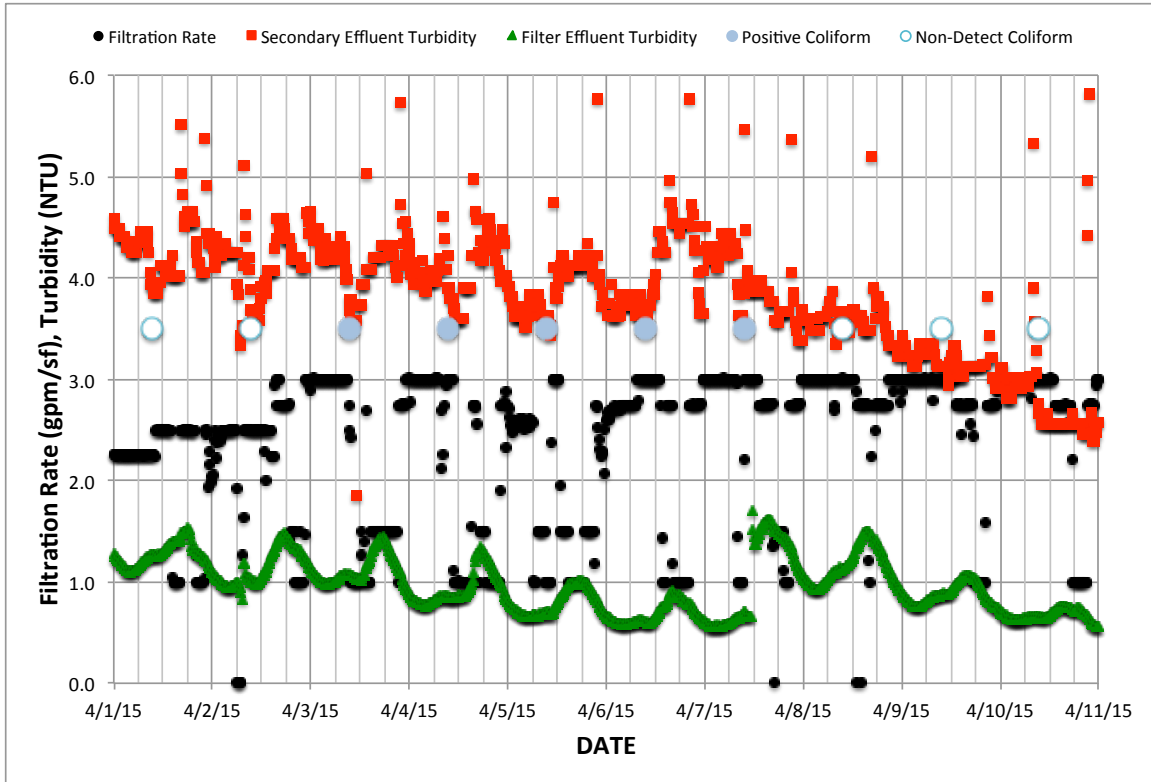

Figure 11 – Granular Media Filter Performance and Chemical Usage April 2015

Figure 11 highlights that flow variability was more significant preceding positive coliform samples and the filtration rate was more consistent when non-detect coliform were collected. A peak coliform concentration of 300 MPN/100 mL was observed on 4/6/15 following a period of significant flow variation. Figure 12 presents an operational period in June when no coliform detections were reported and illustrates that the flow was relatively more consistent prior to each sample.

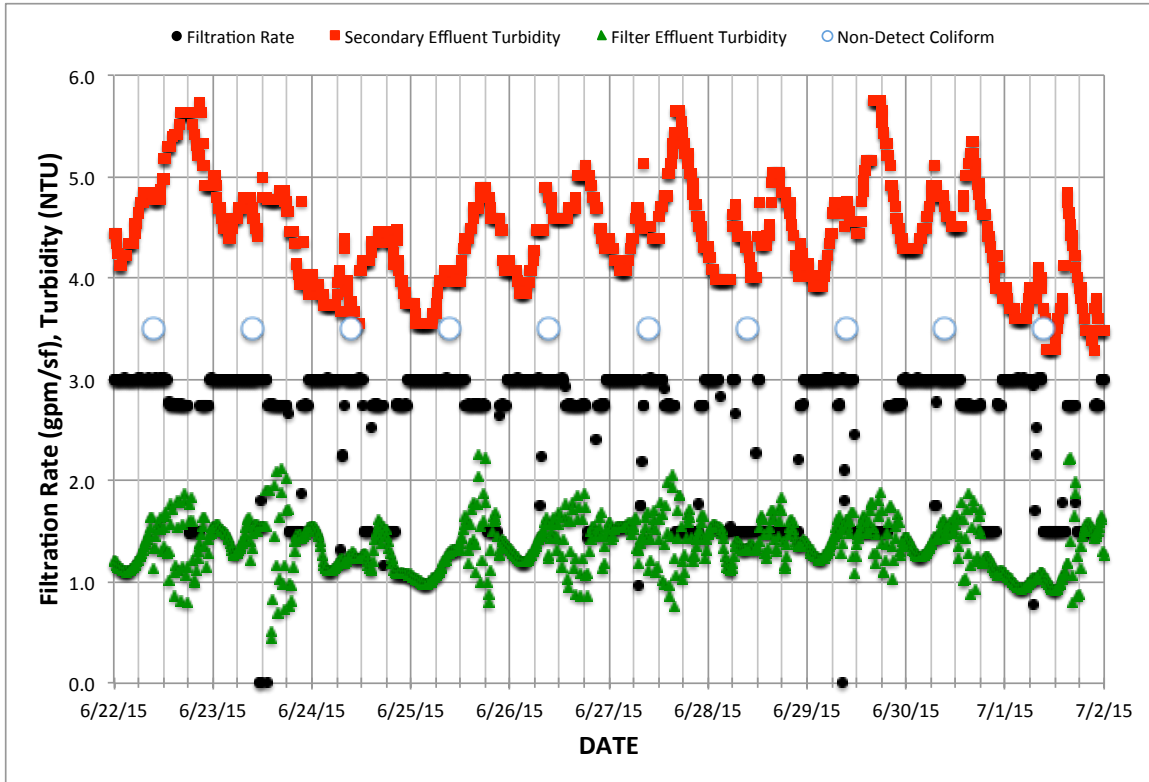

Figure 12 – Granular Media Filter Performance and Chemical Usage June 2015

The cause of the flow variation is the limited on-site storage and the need to meet recycled water demands. The GMF is programmed to run at different flow set points based on tank levels in the recycled water distribution system and peak demand typically occurs overnight. Although there is a capital improvement project to nearly double the storage in the recycled water distribution system, the need for on-site storage remains a critical factor to allow the tertiary operations to reduce flow variations and provide a stable tertiary production rate.

4 - CHLORINE DISINFECTION SYSTEM

Chlorine is dosed into the 12” diameter GMF filtrate pipeline using a 12.5% sodium hypochlorite solution through a 1” PVC pipe (Figure 11). This chlorine injection setup should provide adequate mixing as conditions are turbulent in the 12” pipe ($Re > 4000$ at minimum flow) and flow travels approximately two feet prior to entering a rapid mix chamber at the head of the CCB.

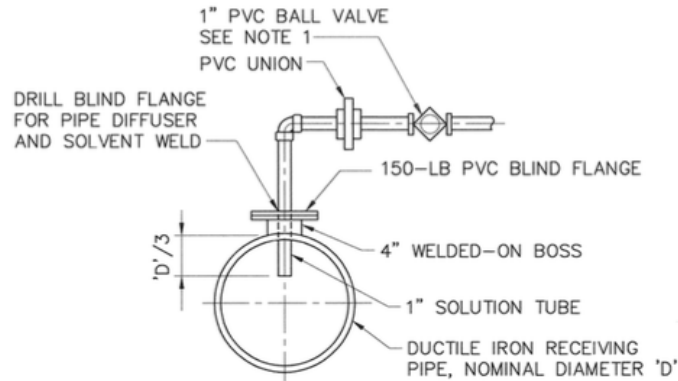

Figure 13 – Chlorine Injection Detail

In the rapid mix chamber up to 0.5 MGD of MF/RO product water is also introduced. The RO product water is already chloraminated as a chloramine residual between 3 and 5 mg/L is maintained to prevent biofouling on the MF and RO membranes. The AWPf product water has been demonstrated to have insignificant coliform concentrations in a sampling study that was conducted from November 2013 through April 2014 (Figure 14). Figure 14 compares the coliform concentrations present in the GMF filtrate to the MF/RO product water, highlighting that the GMF filtrate is the source of coliform that must be disinfected through the chlorine contact basin.

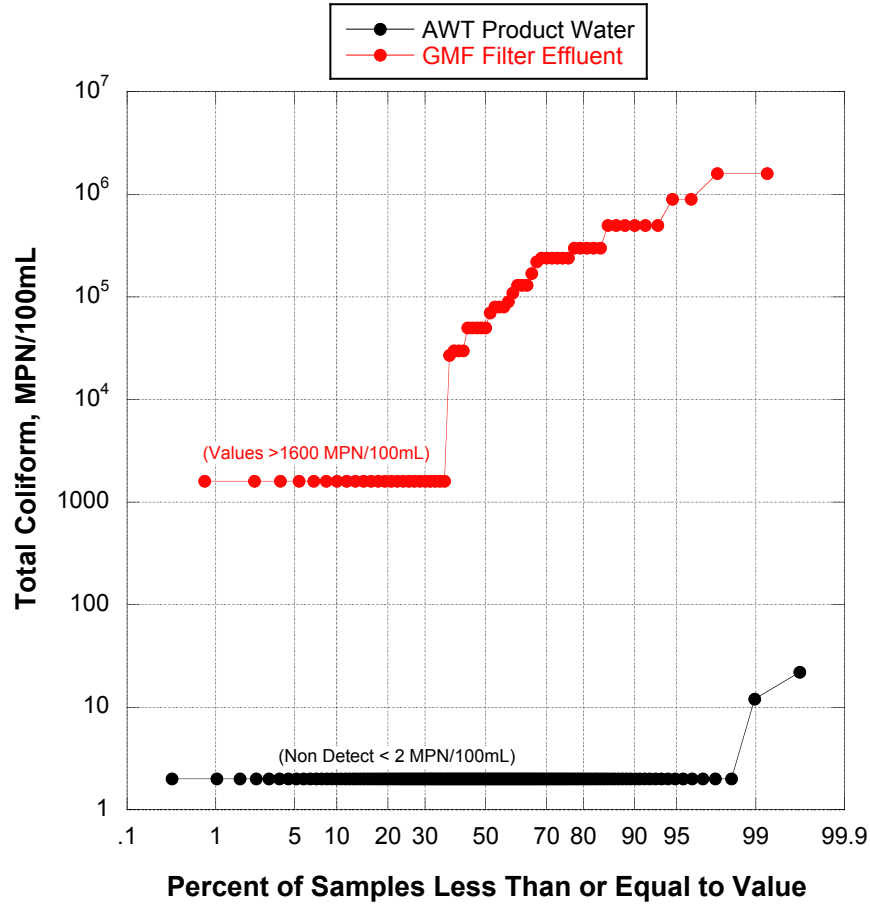

Figure 14 – Filtered Water Coliform Comparison (Pre-Disinfection)

After the chlorine addition and rapid mix, the blend of GMF filtrate and AWPf product water enter the chlorine contact basin. The chlorine contact basin (CCB) is covered to prevent algae growth and contamination (e.g., bird droppings) as well as minimize chlorine destruction due to sunlight. The CCB consists of four-passes and each pass has a length to width ratio of 10:1 (88 ft long by 8.83 ft width). The CCB effluent weir, which is at a fixed height, sets the water level and volume of the CCB. The design sidewater depth is 8.83 ft. Trussell Technologies performed tracer studies in 2009 and 2010 that demonstrated a modal contact time of 99 minutes at 3.02 MGD. Additional tracer tests at flows of 0.84, 1.72 and 2.60 MGD resulted in longer detention times (i.e., 221, 166, and 114 minutes, respectively).

Coliform is sampled daily from the effluent chlorine analyzer’s sample line. This technique is common practice at many operating facilities. The sample bottle contains a de-chlorinating agent so the chlorine residual is quenched at the time of the sample. The samples are then analyzed in SEWRF’s on-site laboratory using the multiple tube method to determine the most probable number of coliform (MPN) per 100 mL of sample.



Parallel sampling was performed for coliform analysis, (1) directly from the recycled water wet well using a long pole and autoclaved sampling container and (2) from the chlorine analyzer sample line as per typical compliance sampling from December 2013 through April 2014. This was a trial experiment to see if the sample line that is typically used for coliform sampling could be contaminating samples. After collecting both data sets for nearly 5 months, the sampling location did not appear to have much influence because certain days the chlorine analyzer sample would be positive while the recycled water wet well would be negative and vice-versa. Since little significance was perceived at the time, parallel sampling was discontinued and compliance sampling resumed from the chlorine analyzer sample line. Figure 15 presents both sets of coliform sampling data as a probability plot below.

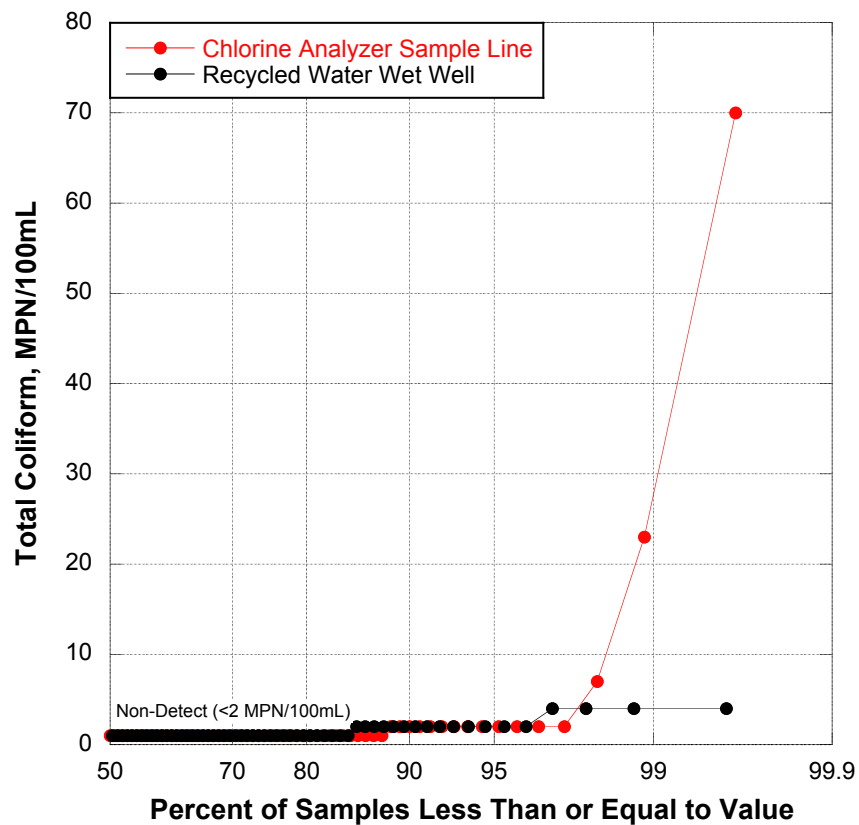

Figure 15 – Probability of Total Coliform for Two Sample Points from December 2013 to April 2014

Figure 15 reveals that there were similar number of positive coliform results at each sample location, however there were several samples taken from the chlorine analyzer sample line that were significantly higher than anything observed in the recycled water wet well. This result indicates that there may be microbiological contamination associated with using the chlorine analyzer sample line. An EPA white paper documented this type of occurrence in 2002 (EPA, 2002).



5 - BENCH-SCALE TESTING

Some bench-scale testing was performed to investigate the coliform particle shielding and the sampling conditions are summarized in Table 2. The intent of these tests was to investigate (1) the impact that the varying filtration rate had on the coliform concentrations and (2) the ability to inactivate coliform with chloramines.

Table 2 – Test Plan and Execution of SEWRF Total Coliform Violation Study

Sample No.	Filter Cell #	Filter Loading Rate (gpm/ft ²)	Test Date
1	4	3	April 22, 2015
2	4	5	April 22, 2015
3	3	1.5	May 19, 2015
4	3	5	May 19, 2015

Four filter effluent samples were collected at different filter loading rates. Sample 1 was taken at a typical loading rate of 3 gpm/ft² and then the flow was increased to 5 gpm/ft² prior to collecting Sample 2. A similar procedure was used to collect Samples 3 and 4 but with a lower starting filtration rate of 1.5 gpm/ft². The collected water samples were analyzed for coliform and then dosed with 10 mg/L of chlorine and mixed on a stir plate. Coliform samples were then collected at specific time intervals to determine the inactivation as CT increased.

Figures 16 and 17 present the results from the bench-scale testing. Both figures show that the coliform concentration is increased with an increase in the filter loading rate, which will require a greater inactivation of coliform to achieve regulatory compliance. The increase in the initial coliform concentrations of Samples 2 and 4 compared to Samples 1 and 3 resulted in higher coliform concentrations even as CT was increased. Figure 16 shows that coliform concentrations reach 2 MPN/100 mL after approximately 190 mg/L-min. Although Sample 2 achieved non-detect at 190 mg/L-min, samples collected after this resulted in positive coliform detections 3 out of 6 times with a tailing coliform concentration of 4 MPN/100 mL observed at 920 mg/L-min. This particular data point highlights that the water contained particles that were adequately shielded from the chloramines that they could be cultured to a concentration above the detection limit. Although Sample 1 also experienced a positive of 2 MPN/100 mL at 920 mg/L-min, there were a total of six coliform samples that were all at 2



MPN/100 mL or less after 190 mg/L-min, which is below the median concentration required for regulatory compliance.

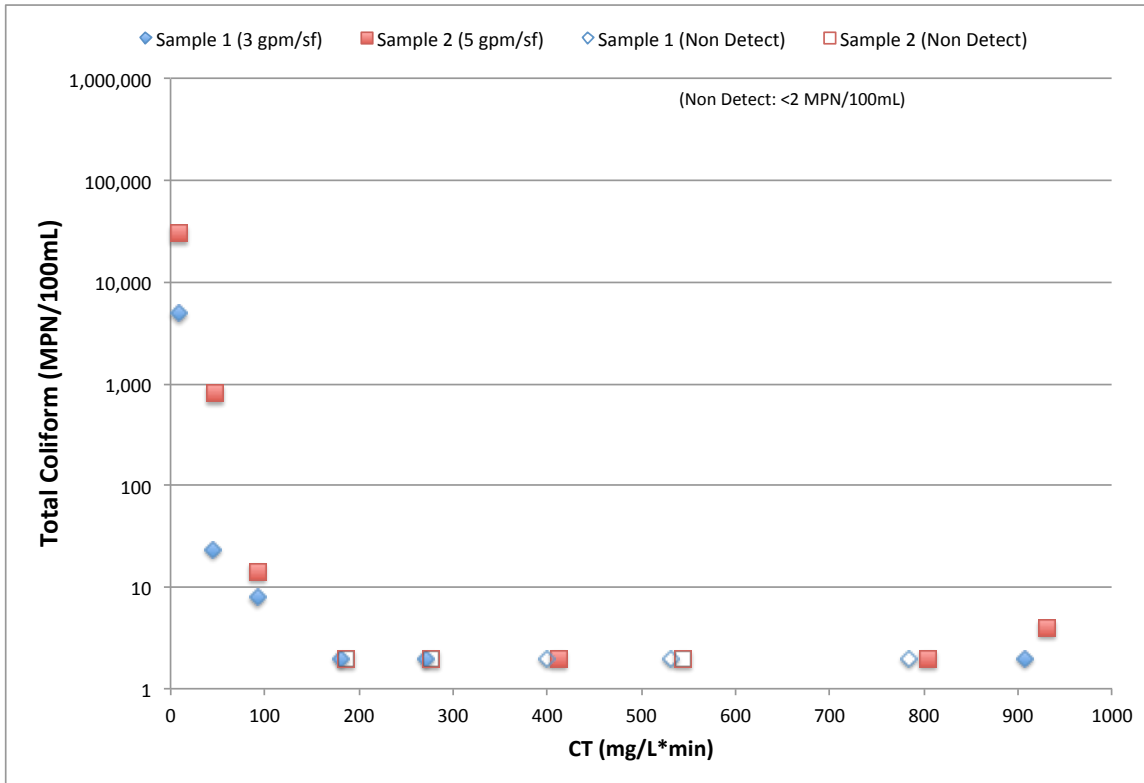

Figure 16 – Filter Effluent Total Coliform Versus CT at 3 vs. 5 gpm/sf

Similar to Figure 16, Figure 17 also shows that coliform concentrations reached less than 2 MPN/100 mL at approximately 150 mg/L-min. The coliform concentrations for Sample 4 were higher than Sample 3 for all samples collected. After achieving coliform concentrations below detection, Sample 3 remained non-detect while Sample 4 did experience another positive coliform. Observing Figures 16 and 17, the water samples collected at higher filtration rates were more likely to have a positive coliform concentration reported after non-detect concentrations were achieved. For example, Samples 1 and 3 only experienced 1 positive out of 9 samples (11% of the time) once a non-detect coliform concentration was achieved. In contrast, Samples 2 and 4 experienced 4 positives out of 12 samples (33% of the time) once a non-detect coliform concentration was achieved.

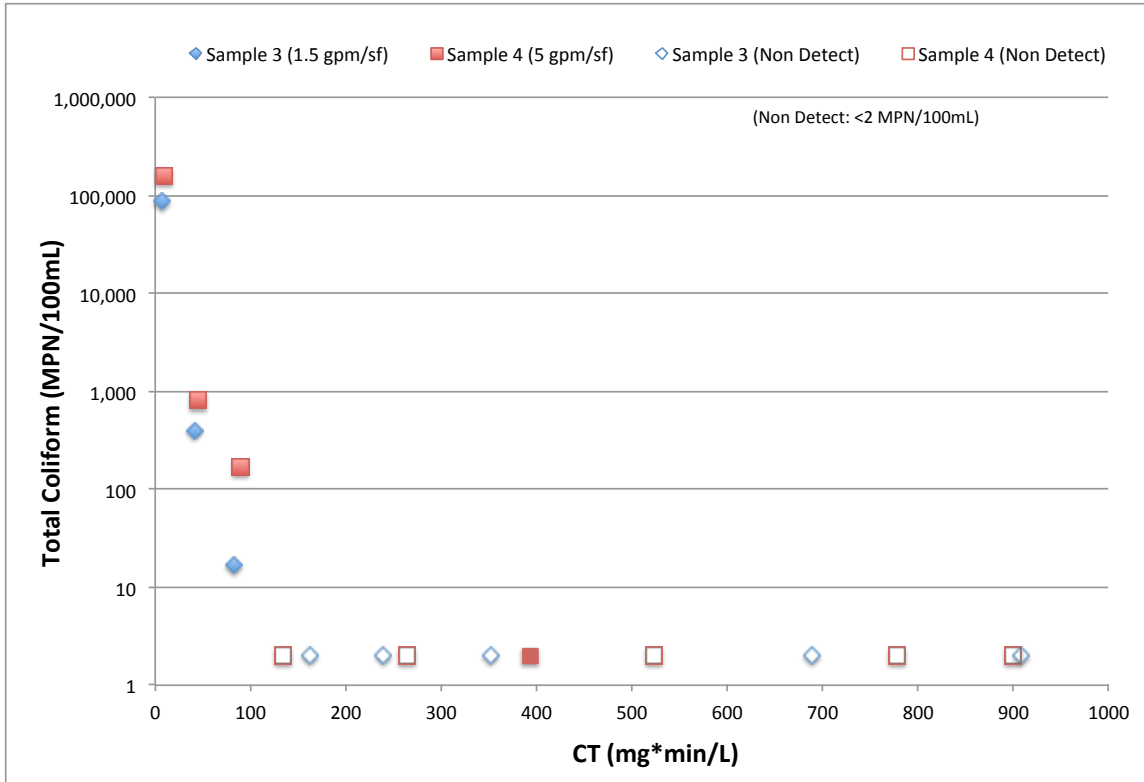

Figure 17 – Filter Effluent Total Coliform Versus CT at 1.5 vs. 5 gpm/sf

6 - CONCLUSIONS AND RECOMMENDATIONS

The historical data analysis and bench-scale testing lead to the following conclusions:

- The filters and chlorine disinfection systems continuously comply with all turbidity and CT required by Title 22
- Flow fluctuations through the filters in 2013 led to significant coliform concentrations and violations when the AWPf was brought on-line
- Reducing flow fluctuations through programming changes reduced the incidence of coliform detections and compliance issues in 2014
- The particle shielding is believed to be biological in nature and not a chemical precipitant because the coagulant use did not correlate with coliform events
- Coliform concentrations in the GMF effluent are high due to the nature of this filtration process while the AWPf effectively produces non-detect coliform
- Sampling from the chlorine analyzer line resulted in positive coliform values that may not be representative of sampling directly from the recycled water wet well

Based on these findings, the following operational changes are recommended:

- Increase the frequency of manual cleanings to one filter per month on a rotating basis such that each filter is cleaned every four months following the manufacturer's recommended routine cleaning procedure. On an annual basis, follow a filter clean with an overnight soak in 2000 mg/L Cl₂ solution.



- Reduce the ramp speed for the tertiary pumps to minimize the hydraulic surging and potential for sloughing/particle shielding from the filters. If possible, operate the filters at a constant speed of 1200 gpm or 3 gpm/sf.
- Minimize the potential for sample contamination by changing the sample point to the CCB effluent weir. Prior to collecting the sample, ensure that there is flow through the CCB and follow proper sampling procedures.

Based on these findings, the following capital improvements are recommended:

- Evaluate the feasibility of replacing the GMF with membrane filtration
- Evaluate the feasibility of providing on-site storage for recycled water



7 - REFERENCES

Dietrich, J.P., Basagaoglu, H., Loge, F.J., Ginn, T.R., 2003. Preliminary Assessment of Transport Processes Influencing the Penetration of Chlorine into Wastewater Particles and the Subsequent Inactivation of Particle-Associated Organisms. *Water Res.* 37, 139–149.

Winward G.P., Avery, L. M., Stephenson, T., Jefferson, B., 2008. Chlorine Disinfection of Grey Water for Reuse: Effect of Organics and Particles. *Water Res.* 42, 483-491.

Geo. Clifford White, 1978. *Disinfection of Wastewater and Water for Reuse.*

EPA, June 17, 2002. *Health Risks from Microbial Growth and Biofilms in Drinking Water Distribution Systems.*

SAN ELIJO JOINT POWERS AUTHORITY
MEMORANDUM

November 9, 2015

TO: Board of Directors
San Elijo Joint Powers Authority

FROM: Director of Finance and Administration

SUBJECT: 2014-15 FINANCIAL AUDIT ACCEPTANCE

RECOMMENDATION

It is recommended that the Board of Directors:

1. Accept and file the 2014-15 Fiscal Year Audit for the San Elijo Joint Powers Authority; and
2. Discuss and take action as appropriate.

DISCUSSION

The financial audit of the San Elijo Joint Powers Authority (SEJPA) for Fiscal Year 2014-2015 has been completed with an unmodified or “clean” opinion on the basic Financial Statements. The audit is now being presented to the SEJPA Board of Directors for approval. The SEJPA auditor, Leaf & Cole, LLP has performed this audit in accordance with auditing standards generally accepted in the United States of America and the State Controller’s Minimum Audit Requirements for California Special Districts.

As part of the audit, Leaf & Cole, LLP is required by professional standards to communicate to the Board of Directors certain information related to the audit. This letter is required to include information related to accounting practices, audit difficulties, disagreements with management, management representations, corrected and uncorrected misstatements, and other audit findings, issues or matters. No transactions were noted where there was a lack of authoritative guidance or consensus. The financial statement disclosures are neutral, consistent, and clear. There were no significant difficulties or disagreements with management in performing and completing the audit. Included with this letter is the list of adjustments made during the audit process. The adjustments were due to the new Government Accounting Standards Board’s Statement No. 68 (GASB 68), Accounting and Financial Reporting for Pensions. This new financial reporting requirement focuses on improving accountability and transparency in the agency’s pension information.

The audited financial statements include the following sections:

- Independent Auditor's Report
- Management Discussion and Analysis
- Statement of Net Position
- Statements of Revenues, Expenses, and Changes in Net Position
- Statements of Cash Flows
- Notes to Financial Statements
- Supplementary Information - Wastewater and Reclamation Basic Financial Statements

Mr. Michael Zizzi, CPA, engagement partner for the audit, will give a presentation to the Board of Directors summarizing the audit and answer any questions.

It is therefore recommended that the Board of Directors:

1. Accept and file the 2014-15 Fiscal Year Audit for the San Elijo Joint Powers Authority; and
2. Discuss and take action as appropriate.

Respectfully submitted,



Paul F. Kinkel
Director of Finance & Administration

Attachment 1: Auditor's communication to those charged with governance (Statements on Auditing Standards 114)

Attachment 2: San Elijo Joint Powers Authority Financial Statements June 30, 2015



Leaf & Cole, LLP
Certified Public Accountants
A Partnership of Professional Corporations

ATTACHMENT 1

Steven W. Northcote, C.P.A.
Michael S. Schreiberman, C.P.A.
Michael J. Zizzi, C.P.A.
Julie A. Firl, C.P.A.
Nicholas M. Gines, C.P.A.

Members
American Institute of Certified Public Accountants
California Society of Certified Public Accountants

To the Board of Directors
San Elijo Joint Powers Authority
2695 Manchester Avenue
Cardiff by the Sea, California 92007

We have audited the financial statements of San Elijo Joint Powers Authority for the year ended June 30, 2015. Professional standards require that we provide you with the following information related to our audit.

Our Responsibility Under U.S. Generally Accepted Auditing Standards

As stated in our engagement letter dated May 18, 2015, our responsibility, as described by professional standards, is to express an opinion about whether the financial statements prepared by management with your oversight are fairly presented, in all material respects, in conformity with U.S. generally accepted accounting principles. Our audit of the financial statements does not relieve you or management of your responsibilities.

Our responsibility is to plan and perform the audit to obtain reasonable, but not absolute, assurance that the financial statements are free of material misstatement.

As part of our audit, we considered the internal control of San Elijo Joint Powers Authority. Such considerations were solely for the purpose of determining our audit procedures and not to provide any assurance concerning such internal controls.

Our responsibility for the supplementary information accompanying the financial statements, as described by professional standards, is to evaluate the presentation of the supplementary information in relation to the financial statements as a whole and to report on whether the supplementary information is fairly stated, in all material respects, in relation to the financial statements as a whole.

We are responsible for communicating significant matters related to the audit that are, in our professional judgment, relevant to your responsibilities in overseeing the financial reporting process. However, we are not required to design procedures specifically to identify such matters.

Planned Scope and Timing of the Audit

An audit includes examining, on a test basis, evidence supporting the amounts and disclosures in the financial statements; therefore, our audit will involve judgment about the number of transactions examined and the areas tested.

Our audit included obtaining an understanding of the SEJPA and its environment, including internal control, sufficient to assess the risks of material misstatement of the financial statements and to design the nature, timing, and extent of further audit procedures. Material misstatements may result from (1) errors, (2) fraudulent financial reporting, (3) misappropriation of assets, or (4) violations of laws or governmental regulations that are attributable to the entity or to acts by management or employees acting on behalf of the SEJPA.

Significant Audit Findings

Qualitative Aspects of Accounting Practices

Management is responsible for the selection and use of appropriate accounting policies. The significant accounting policies used by SEJPA are described in Note 1 to the financial statements. As described in Note 17, SEJPA changed accounting policies related to accounting and financial reporting for pensions by adopting GASB 68, in the year ended June 30, 2015. We noted no transactions entered into by SEJPA during the year for which there is a lack of authoritative guidance or consensus. All significant transactions have been recognized in the financial statements in the proper period.

Accounting estimates are an integral part of the financial statements prepared by management and are based on management's knowledge and experience about past and current events and assumptions about future events. Certain accounting estimates are particularly sensitive because of their significance to the financial statements and because of the possibility that future events affecting them may differ significantly from those expected. The most sensitive estimates affecting the financial statements were:

- The useful lives assigned to capital assets have been estimated based on the intended use.
- Management has represented no circumstances indicating the carrying value of the long-lived assets was impaired.
- The allowance for doubtful accounts has been estimated based on past experience and on an analysis of current receivable balances.
- Amortization of the deferred amount on refunding and the original issue premium

The disclosures in the financial statements are neutral, consistent, and clear. Certain financial statement disclosures may be particularly sensitive because of their significance to financial statement users. The most sensitive disclosures affecting the financial statements were:

- Cash and Cash Equivalents (Note 2)
- Restricted Assets (Note 4)
- Noncurrent Liabilities (Note 8)
- SFID Reimbursement Agreement Payable (Note 12)
- Defined Benefit Pension Plan (Note 14)
- Change in Accounting Principle (Note 17)

Difficulties Encountered in Performing the Audit

We encountered no significant difficulties in dealing with management in performing and completing our audit.

Corrected and Uncorrected Misstatements

Professional standards require us to accumulate all known and likely misstatements identified during the audit, other than those that are trivial, and communicate them to the appropriate level of management.

- The attached schedule of misstatements detected as a result of audit procedures were corrected by management.

Disagreements With Management

For purposes of this letter, professional standards define a disagreement with management as a financial accounting, reporting, or auditing matter, whether or not resolved to our satisfaction, that could be significant to the financial statements or the auditor's report. We are pleased to report that no such disagreement arose during the course of our audit.

Management Representations

We have requested certain representations from management that are included in the management representation letter.

Management Consultations With Other Independent Accountants

In some cases, management may decide to consult with other accountants about auditing and accounting matters, similar to obtaining a "second opinion" on certain situations. If a consultation involves application of an accounting principle to SEJPA's financial statements or a determination of the type of auditor's opinion that may be expressed on those statements, our professional standards require the consulting accountant to check with us to determine that the consultant has all the relevant facts. To our knowledge, there were no such consultations with other accountants.

Other Audit Findings or Issues

We generally discuss a variety of matters, including the application of accounting principles and auditing standards, with management each year prior to retention as SEJPA's auditors. However, these discussions occurred in the normal course of our professional relationship and our responses were not a condition to our retention.

Other Matters

With respect to the supplementary information accompanying the financial statements, we made certain inquiries of management and evaluated the form, content and methods of preparing the information to determine that the information complied with U.S. generally accepted accounting principles, the method of preparing it has not changed from the prior period, and the information is appropriate and complete in relation to our audit of the financial statements. We compared and reconciled the supplementary information to the underlying accounting records used to prepare the financial statements or to the financial statements themselves.

This information is intended solely for the use of the Board of Directors and management of SEJPA and is not intended to be and should not be used by anyone other than these specified parties.

SAN ELIJO JOINT POWERS AUTHORITY
Adjusting Journal Entries

Reference	Type	Date Account Number	Description	Debit	Credit	Net Income Effect	Workpaper
01	Adjusting	06/30/15					
		2250.20	Deferred Revenue	59,256.00			
		1110.20	Due from Other Gov. Agencies		59,256.00		
			To net the prepayment made by Encinitas Ranch against the receivable balance			0.00	
01	Adjusting	06/30/15					
		3500.10	Retained Earnings	1,939,877.72			
		3500.20	Retained Earnings	320,438.39			
		1700.10	Deferred Outflows - PERS Paymer	220,500.79			
		1700.20	Deferred Outflows - PERS Paymer	36,913.10			
		2700.10	Net Pension Liability		2,160,378.51		
		2700.20	Net Pension Obligation		357,351.49		
			To record the Net Pension Liability as required by GASB 68 at the Valuation Date			0.00	
02	Adjusting	06/30/15					
		2700.10	Net Pension Liability	220,500.79			
		1700.10	Deferred Outflows - PERS Paymer		220,500.79		
		2700.20	Net Pension Obligation	36,913.10			
		1700.20	Deferred Outflows - PERS Paymer		36,913.10		
			To reverse the deferred outflows for payments made to PERS during 2014			0.00	
03	Adjusting	06/30/15					
		1700.10	Deferred Outflows - PERS Paymer	225,869.17			
		1700.20	Deferred Outflows - PERS Paymer	43,153.73			
		5147.10	Retirement Plan - PERS		225,869.17		
		5147.20	Retirement Plan - PERS		43,153.73		
			To defer current year cash payments to PERS			269,022.90	

Reference	Type	Date Account Number	Description	Debit	Credit	Net Income Effect	Workpaper
04	Adjusting	06/30/15					
		5147.10	Retirement Plan - PERS	246,319.56			
		5147.20	Retirement Plan - PERS	41,829.44			
		1710.10	Deferred Outflows - Actuarial	4,055.33			
		1710.20	Deferred Outflows - Actuarial	688.67			
		2710.10	Deferred Inflows Actuarial		492,632.29		
		2710.20	Deferred Inflows - Actuarial		83,657.71		
		2720.10	Deferred Inflows - Additional Defe		33,580.44		
		2720.20	Deferred Inflows - Additional Defe		5,702.56		
		2700.10	Net Pension Liability	275,837.83			
		2700.20	Net Pension Obligation	46,842.17			
						(288,149.00)	
			To record the actuarial deferred inflows and outflows and adjust to the Net Pension liability at the measurement date				
		TOTAL		<u>3,718,995.79</u>	<u>3,718,995.79</u>	<u>(19,126.10)</u>	

ATTACHMENT 2

SAN ELIJO JOINT POWERS AUTHORITY

FINANCIAL STATEMENTS

JUNE 30, 2015

DRAFT



Leaf & Cole, LLP
Certified Public Accountants

**SAN ELIJO JOINT POWERS AUTHORITY
FINANCIAL STATEMENTS
JUNE 30, 2015**

TABLE OF CONTENTS

	<u>Page</u>
Independent Auditor's Report	1 - 3
Management's Discussion and Analysis	4 - 8
Statement of Net Position	9 - 10
Statement of Revenues, Expenses and Changes in Net Position	11
Statement of Cash Flows	12 - 13
Notes to Financial Statements	14 - 37
Required Supplementary Information:	
Schedule of Proportionate Share of the Net Pension Liability	38
Schedule of Plan Contributions	39
Supplementary Information:	
Combining Schedule of Net Position	40 - 41
Combining Schedule of Revenues, Expenses and Changes in Net Position	42
Operating Budget Comparison Schedule - Wastewater	43
Operating Budget Comparison Schedule - Reclamation	44



Leaf & Cole, LLP
Certified Public Accountants
A Partnership of Professional Corporations

Steven W. Northcote, C.P.A.
Michael S. Schreiberman, C.P.A.
Michael J. Zizzi, C.P.A.
Julie A. Firl, C.P.A.
Nicholas M. Gines, C.P.A.

Members
American Institute of Certified Public Accountants
California Society of Certified Public Accountants

Independent Auditor's Report

To the Board of Directors
San Elijo Joint Powers Authority
2695 Manchester Avenue
Cardiff by the Sea, California 92007

Report on Financial Statements

We have audited the accompanying financial statements of San Elijo Joint Powers Authority, which comprise the statement of net position as of June 30, 2015, and the related statements of revenues, expenses, and changes in net position and cash flows for the year then ended, and the related notes to the financial statements.

Management's Responsibility for the Financial Statements

Management is responsible for the preparation and fair presentation of these financial statements in accordance with accounting principles generally accepted in the United States of America; this includes the design, implementation, and maintenance of internal control relevant to the preparation and fair presentation of financial statements that are free from material misstatement, whether due to fraud or error.

Auditor's Responsibility

Our responsibility is to express an opinion on these financial statements based on our audit. We conducted our audit in accordance with auditing standards generally accepted in the United States of America and the State Controller's Minimum Audit Requirements for California Special Districts. Those standards require that we plan and perform the audit to obtain reasonable assurance about whether the financial statements are free from material misstatement.

An audit involves performing procedures to obtain audit evidence about the amounts and disclosures in the financial statements. The procedures selected depend on the auditor's judgment, including the assessment of the risks of material misstatement of the financial statements, whether due to fraud or error. In making those risk assessments, the auditor considers internal control relevant to the entity's preparation and fair presentation of the financial statements in order to design audit procedures that are appropriate in the circumstances, but not for the purpose of expressing an opinion on the effectiveness of the entity's internal control. Accordingly, we express no such opinion. An audit also includes evaluating the appropriateness of accounting policies used and the reasonableness of significant accounting estimates made by management, as well as evaluating the overall presentation of the financial statements.

We believe that the audit evidence we have obtained is sufficient and appropriate to provide a basis for our audit opinion.

Opinion

In our opinion, the financial statements referred to above present fairly, in all material respects, the financial position of San Elijo Joint Powers Authority as of June 30, 2015, and the changes in financial position and cash flows for the year then ended in accordance with accounting principles generally accepted in the United States of America.

Other Matters

Change in Accounting Principle

As described in Note 17 to the financial statements, the San Elijo Joint Powers Authority changed its method of accounting and financial reporting for pensions in order to conform with "Governmental Accounting Standards Board Statement No. 68, Accounting and Financial Reporting for Pensions." Our opinion is not modified with respect to this matter.

Required Supplementary Information

Accounting principles generally accepted in the United States of America require that the management's discussion, analysis and the schedule of proportionate share of the net pension liability and the schedule of Plan contributions, as identified in the accompanying table of contents be presented to supplement the financial statements. Such information, although not a part of the basic financial statements, is required by the Governmental Accounting Standards Board, who considers it to be an essential part of financial reporting for placing the basic financial statements in an appropriate operational, economic, or historical context. We have applied certain limited procedures to the required supplementary information in accordance with auditing standards generally accepted in the United States of America, which consisted of inquiries of management about the methods of preparing the information and comparing the information for consistency with management's responses to our inquiries, the financial statements, and other knowledge we obtained during our audit of the financial statements. We do not express an opinion or provide any assurance on the information because the limited procedures do not provide us with sufficient evidence to express an opinion or provide any assurance.

Other Information

Our audit was conducted for the purpose of forming an opinion on the financial statements of San Elijo JPA. The supplementary combining schedule of net position, combining schedule of revenues, expenses, and changes in net position, the operating budget comparison schedule - wastewater, and the operating budget comparison schedule - reclamation are presented for purposes of additional analysis and are not a required part of the basic financial statements.

The supplementary combining schedule of net position and combining schedule of revenues, expenses, and changes in net position are the responsibility of management and were derived from and relate directly to the underlying accounting and other records used to prepare the basic financial statements. Such information has been subjected to the auditing procedures applied in the audit of the basic financial statements and certain additional procedures, including comparing and reconciling such information directly to the underlying accounting and other records used to prepare the basic financial statements or to the basic financial statements themselves, and other additional procedures in accordance with auditing standards generally accepted in the United States of America. In our opinion, the combining schedule of net position, combining schedule of revenues, expenses, and changes in net position are fairly stated, in all material respect, in relation to the basic financial statements as a whole.

To the Board of Directors
San Elijo Joint Powers Authority

Page 3

The operating budget comparison schedule - wastewater and the operating budget comparison schedule - reclamation have not been subjected to the auditing procedures applied in the audit of the financial statements and, accordingly, we do not express an opinion or any assurance on them.

San Diego, California
October __, 2015

DRAFT

MANAGEMENT'S DISCUSSION AND ANALYSIS

Our discussion and analysis of the financial performance of the San Elijo Joint Powers Authority's (SEJPA) provides an overview of the SEJPA's financial activities as of and for the year ended June 30, 2015. Please read it in conjunction with the SEJPA's financial statements which begin on page 9.

Financial Statements

This discussion and analysis provides an introduction and a brief description of the SEJPA's financial statements, including the relationship of the statements to each other and the significant differences in the information they provide. The SEJPA's financial statements include four components:

- Statement of Net Position
- Statement of Revenues, Expenses and Changes in Net Position
- Statement of Cash Flows
- Notes to the Financial Statements

The statement of net position includes all of the SEJPA's assets, deferred outflows of resources, liabilities and deferred inflows of resources, with the difference reported as net position. Net position may be displayed in three categories:

- Net Investment in Capital Assets
- Restricted Net Position
- Unrestricted Net Position

The statement of net position provides the basis for computing rate of return evaluating the capital structure of the SEJPA and assessing its liquidity and financial flexibility.

The statement of revenues, expenses and changes in net position presents information which shows how the SEJPA's net position changed during the year. All of the current year's revenues and expenses are recorded when the underlying transaction occurs, regardless of the timing of the related cash flows. The statement of revenues, expenses and changes in net position measures the success of the SEJPA's operations over the past year and determines whether the SEJPA has recovered its costs through charges for services and other charges.

The statement of cash flows provides information regarding the SEJPA's cash receipts and cash disbursements during the year. This statement may report cash activity in four categories:

- Operations
- Capital and related financing
- Noncapital financing
- Investing

This statement differs from the statement of revenues, expenses and changes in net position because the statement accounts only for transactions that result in cash receipts or cash disbursements.

The notes to the financial statements provide a description of the accounting policies used to prepare the financial statements and present material disclosures required by generally accepted accounting principles that are not otherwise present in the financial statements.

MANAGEMENT'S DISCUSSION AND ANALYSIS

Financial Highlights

- The SEJPA's net position increased by \$600,438 to \$37,715,634 for the year ended June 30, 2015, after adjusting for the effects of the implementation of GASB 68, (See Note 17).
- The SEJPA's revenues totaled \$7,811,839 for the year ended June 30, 2015, a decrease of \$755,663 resulting principally from a decrease in state grants.
- The SEJPA's expenses totaled \$7,211,401 for the year ended June 30, 2015. Nearly half of the 3% increase from the previous year can be found in depreciation and amortization.

Financial Analysis of the SEJPA

Net Position

The following is a summary of the SEJPA's statements of net position at June 30:

	<u>2015</u>	<u>2014</u> ⁽¹⁾	<u>Change</u>
<u>Assets:</u>			
Current and other assets	\$ 13,756,350	\$ 15,435,274	\$ (1,678,924)
Capital assets	39,778,414	39,607,816	170,598
Total Assets	<u>53,534,764</u>	<u>55,043,090</u>	<u>(1,508,326)</u>
<u>Deferred Outflows of Resources</u>	<u>469,877</u>	<u>237,396</u>	<u>232,481</u>
<u>Liabilities:</u>			
Current liabilities	2,542,516	2,609,352	(66,836)
Noncurrent liabilities	13,130,919	13,295,622	(164,703)
Total Liabilities	<u>15,673,435</u>	<u>15,904,974</u>	<u>(231,539)</u>
<u>Deferred Inflows of Resources</u>	<u>615,572</u>	<u>-</u>	<u>615,572</u>
<u>Net Position:</u>			
Net investment in capital assets	32,631,542	31,647,687	983,855
Restricted	630,000	630,000	-
Unrestricted	4,454,092	7,097,825	(2,643,733)
Total Net Position	<u>\$ 37,715,634</u>	<u>\$ 39,375,512</u>	<u>\$ (1,659,878)</u>

- ⁽¹⁾ 2014 figures have not been restated as the deferred outflows of resources and the deferred inflows of resources resulting from the implementation of GASB Statement No. 68, "Accounting and Financial Reporting for Pensions" were not available for the year ended June 30, 2014.

Net position increased by \$600,438 from fiscal year 2014 to 2015. Net investment in capital assets increased \$983,555 in fiscal year 2015. This increase is the result of principal paid on the SEJPA's long-term debt and the increase in investment in capital assets, net of depreciation expense.

MANAGEMENT'S DISCUSSION AND ANALYSIS

Financial Analysis of the SEJPA (Continued)

Net Position (Continued)

Restricted net position is unchanged for the year ended June 30, 2015 as funds restricted for reserves remain in place.

Unrestricted net assets (those that can be used to finance day-to-day operations) decreased \$383,417 after adjusting for the effects of the implementation of GASB 68, (See Note 17) due to unrestricted funds being used to fund debt service.

Revenues, Expenses and Changes in Net Position

The following is a summary of the SEJPA's revenues, expenses and changes in net position for the years ended June 30:

	<u>2015</u>	<u>2014</u> ⁽¹⁾	<u>Change</u>
Operating contributions from members	\$ 3,094,069	\$ 3,035,502	\$ 58,567
Charges for services to other government agencies	3,430,206	3,464,930	(34,724)
Other nonoperating revenue	285,019	322,764	(37,745)
Member agency assessments	903,806	952,381	(48,575)
State grants	98,739	791,925	(693,186)
Total Revenues	<u>7,811,839</u>	<u>8,567,502</u>	<u>(755,663)</u>
Operating expenses	6,815,073	6,529,633	285,440
Interest expense	396,328	448,098	(51,770)
Total Expenses	<u>7,211,401</u>	<u>6,977,731</u>	<u>233,670</u>
Increase in Net Position	<u>\$ 600,438</u>	<u>\$ 1,589,771</u>	<u>\$ (989,333)</u>

⁽¹⁾ 2014 figures have not been restated as the deferred outflows of resources and the deferred inflows of resources resulting from the implementation of GASB Statement No. 68, "Accounting and Financial Reporting for Pensions" were not available for the year ended June 30, 2014.

A closer examination of the source of changes in net position reveals that the SEJPA's total revenues decreased by \$755,663 in fiscal year 2015. Over 91% of this decrease is attributable to a decrease in state grants. As noted previously, total costs grew by 3% with nearly half of that increase attributable to depreciation and amortization.

MANAGEMENT'S DISCUSSION AND ANALYSIS

Financial Analysis of the SEJPA (Continued)

Capital Assets

Capital assets consist of the following at June 30:

	<u>2015</u>	<u>2014</u> ⁽¹⁾	<u>Change</u>
Plant equipment	\$ 67,832,748	\$ 66,699,808	\$ 1,132,940
Lab equipment	110,294	130,340	(20,046)
Office equipment	79,786	117,476	(37,690)
Vehicles	289,287	302,543	(13,256)
Construction-in-progress	1,124,406	446,311	678,095
Subtotal	<u>69,436,521</u>	<u>67,696,478</u>	<u>1,740,043</u>
Less: Accumulated depreciation	<u>(29,658,107)</u>	<u>(28,088,662)</u>	<u>(1,569,445)</u>
Net Capital Assets	<u>\$ 39,778,414</u>	<u>\$ 39,607,816</u>	<u>\$ 170,598</u>

- ⁽¹⁾ 2014 figures have not been restated as the deferred outflows of resources and the deferred inflows of resources resulting from the implementation of GASB Statement No. 68, "Accounting and Financial Reporting for Pensions" were not available for the year ended June 30, 2014.

The net additions to capital assets for fiscal year 2015 totaled \$170,598. Capital asset additions included the emergency generator replacement, the OMWD pipeline and the bio-solids conveyor project as well as several smaller projects.

Long-Term Debt

The following is a summary of long-term debt at June 30:

	<u>2015</u>	<u>2014</u> ⁽¹⁾	<u>Change</u>
2011 Refunding Revenue Bonds	\$ 5,585,000	\$ 6,820,000	\$ (1,235,000)
Original Issue Premium, net	<u>379,276</u>	<u>459,123</u>	<u>(79,847)</u>
2011 Refunding Revenue Bonds, Net	<u>5,964,276</u>	<u>7,279,123</u>	<u>(1,314,847)</u>
State Loan Payable	4,597,496	5,299,679	(702,183)
Private Placement Loan Payable	1,757,268	1,830,216	(72,948)
SFID Reimbursement Agreement	<u>453,493</u>	<u>463,815</u>	<u>(10,322)</u>
Total Long-Term Debt	<u>12,772,533</u>	<u>14,872,833</u>	<u>(2,100,300)</u>
Less: Current Portion	<u>(2,060,745)</u>	<u>(2,010,131)</u>	<u>(50,614)</u>
	<u>\$ 10,711,788</u>	<u>\$ 12,862,702</u>	<u>\$ (2,150,914)</u>

- ⁽¹⁾ 2014 figures have not been restated as the deferred outflows of resources and the deferred inflows of resources resulting from the implementation of GASB Statement No. 68, "Accounting and Financial Reporting for Pensions" were not available for the year ended June 30, 2014.

MANAGEMENT'S DISCUSSION AND ANALYSIS

Economic Factors

Consistent with the prior year, SEJPA's fiscal year 2015-16 sanitary fund operations and maintenance budget is \$4,322,203. The water reclamation budget is 1,363,948. Sales of reclaimed water are budgeted to be approximately 1,530 acre feet in the upcoming year. Only a minor increase in revenue is anticipated due to changes in the reclamation sales agreements.

Contingency funding for each program area has been reviewed and budgeted on the basis of the potential for unforeseen events within each activity area. For all programs, the amount in contingency funding is \$129,900 and is \$4,900 higher than last year's budget levels.

The capital project program will have a budget of \$1,597,000 during the upcoming year. This is primarily for improvements to the wastewater, ocean outfall, and reclamation programs.

Costs of sanitary services are allocated on the basis of percentage of use, as indicated by measured flows, or level of effort, as appropriate. On the basis of connected equivalent dwelling units (EDU's) for wastewater treatment provided to the member agencies, the budgeted cost is approximately \$164 per EDU per year for 2015-16. This represents a 0% increase from 2014-2015. The Encinitas Ranch Golf Course pays a set annual price for interruptible water service, which increases 5% annually. For the remaining water agencies, recycled water sales are based on individual contracts which may include minimum annual purchase volumes and negotiated water rate prices. These fees are supplemented by incentives from the Metropolitan Water District and the San Diego County Water Authority.

On October 8, 2012, the Board adopted a resolution to amend the contract between CalPERS and the SEJPA. This resolution amended the contract to include Section 20475 (Different Level of Benefits) for new Miscellaneous Members of the Public Employees' Retirement System, Section 21353 (2% at 60 Full Formula), and Section 20037 (Three-Year Final Compensation) this resolution will be applicable to all SEJPA employees entering membership for the first time in the miscellaneous classification after June 30, 2015. The lower benefit payout will result in a lower contribution rate for the SEJPA in the future as new employees enter the SEJPA workforce. All employees will pay the full employee portion of the CalPERS retirement benefit.

Contacting the Authority's Financial Manager

This financial report is designed to provide our citizens, taxpayers, customers, investors and creditors with a general overview of the SEJPA's finances and to demonstrate the SEJPA's accountability for the money it receives. If you have any questions about this report or need additional financial information, contact the SEJPA, at (760) 753-6203, ext. 73.

**SAN ELIJO JOINT POWERS AUTHORITY
STATEMENT OF NET POSITION
JUNE 30, 2015**

ASSETS

Current Assets: (Notes 1, 2, 3 and 5)

Cash and cash equivalents	\$ 6,776,783
Due from other government agencies	593,767
Accrued interest receivable	74,909
Prepaid expenses	19,026
Current portion of loans receivable	1,265,000
Total Current Assets	8,729,485

Noncurrent Assets: (Notes 1, 2, 4, 5, 6, 7 and 10)

Restricted Assets:

Cash and cash equivalents	630,004
Total Restricted Assets	630,004

Loans Receivable, net of current portion	4,320,000
--	-----------

Capital Assets:

Nondepreciable	1,124,406
Depreciable, net of accumulated depreciation	38,654,008
Total Capital Assets	39,778,414

Other Assets:

Retrofit loans receivable	52,644
Bond insurance costs	24,217
Total Other Assets	76,861

Total Noncurrent Assets	44,805,279
-------------------------	------------

TOTAL ASSETS	53,534,764
---------------------	-------------------

DEFERRED OUTFLOWS OF RESOURCES: (Notes 1, 9 and 17)

Deferred amount on refunding	196,110
Deferred outflows related to contributions	269,023
Deferred outflows related to pensions	4,744
Total Deferred Outflows of Resources	469,877

The accompanying notes are an integral part of the financial statements.

**SAN ELIJO JOINT POWERS AUTHORITY
STATEMENT OF NET POSITION (CONTINUED)
JUNE 30, 2015**

LIABILITIES

Current Liabilities: (Notes 1, 8, 9, 10 and 11)

Accounts payable	\$ 172,427
Accrued liabilities	84,622
Accrued interest payable	175,920
Retention payable	48,802
Current portion of refunding revenue bonds	1,265,000
Current portion of state loan payable	719,738
Current portion of private placement loan payable	76,007
Total Current Liabilities	2,542,516

Noncurrent Liabilities: (Notes 1, 4, 8, 9, 10, 11, 12, 13 and 14)

Payable From Restricted Assets:

Due to member agencies payable from restricted assets	4
---	---

Long-Term Debt:

Refunding revenue bonds, net of current portion	4,699,276
State loan payable, net of current portion	3,877,758
Private placement loan payable, net of current portion	1,681,261
SFID reimbursement agreement payable	453,493
Total Long-Term Debt	10,711,788

Other Noncurrent Liabilities:

Net pension liability	1,937,636
Net OPEB obligation	137,538
Compensated absences	343,953
Total Other Noncurrent Liabilities	2,419,127

Total Noncurrent Liabilities	13,130,919
------------------------------	------------

Total Liabilities	15,673,435
-------------------	------------

DEFERRED INFLOWS OF RESOURCES (Notes 1, 14 and 17)

Deferred inflows related to pensions	615,572
--------------------------------------	---------

Commitments and Contingencies (Notes 13, 14 and 15)

NET POSITION: (Note 17)

Net investment in capital assets	32,631,542
Restricted	630,000
Unrestricted	4,454,092
Total Net Position	\$ 37,715,634

The accompanying notes are an integral part of the financial statements.

**SAN ELIJO JOINT POWERS AUTHORITY
STATEMENT OF REVENUES, EXPENSES AND CHANGES IN NET POSITION
FOR THE YEAR ENDED JUNE 30, 2015**

Operating Revenues:

Charges for services to other government agencies	\$ 3,430,206
Contributions from City of Encinitas	1,646,210
Contributions from City of Solana Beach	1,447,859
Total Operating Revenues	<u>6,524,275</u>

Operating Expenses:

Personnel costs	2,670,636
Depreciation and amortization	1,831,903
Utilities	811,032
Contracted services	590,388
Supplies	267,493
Disposal services	208,836
Miscellaneous	178,541
Repair parts expense	118,632
Permit/purveyor fees	81,337
Insurance	56,275
Total Operating Expenses	<u>6,815,073</u>

Operating Loss (290,798)

Nonoperating Revenues (Expenses):

Investment income	255,283
State grants	98,739
Rental income	25,091
Other	4,421
Gain on disposal of capital assets	224
Interest expense	<u>(396,328)</u>
Total Nonoperating Revenues (Expenses)	<u>(12,570)</u>

Loss Before Capital Contributions (303,368)

Capital Contributions:

Member agency assessments	<u>903,806</u>
Total Capital Contributions	<u>903,806</u>

Change in Net Position 600,438

Net Position at Beginning of Year, as Restated (Note 17) 37,115,196

NET POSITION AT END OF YEAR \$ 37,715,634

The accompanying notes are an integral part of the financial statements.

**SAN ELIJO JOINT POWERS AUTHORITY
STATEMENT OF CASH FLOWS
FOR THE YEAR ENDED JUNE 30, 2015**

<u>Cash Flows From Operating Activities:</u>	
Cash received from customers	\$ 6,468,416
Cash payments to suppliers for goods and services	(2,299,245)
Cash payments to employees for services	(2,570,574)
Net Cash Provided by Operating Activities	<u>1,598,597</u>
<u>Cash Flows From Noncapital and Related Financing Activities:</u>	
Rental and other nonoperating income	29,512
Net Cash Provided by Noncapital and Related Financing Activities	<u>29,512</u>
<u>Cash Flows From Capital and Related Financing Activities:</u>	
Acquisition and construction of capital assets	(1,977,444)
Proceeds from sale of capital assets	1,115
Principal paid on long-term debt	(2,020,453)
Interest paid on long-term debt	(457,331)
Proceeds of state grants	95,839
Capital contributions	903,806
Net Cash Used in Capital and Related Financing Activities	<u>(3,454,468)</u>
<u>Cash Flows From Investing Activities:</u>	
Proceeds from loans receivable	1,235,000
Proceeds from retrofit loans receivable	30,539
Investment income	265,360
Net Cash Provided by Investing Activities	<u>1,530,899</u>
Net Decrease in Cash and Cash Equivalents	(295,460)
Cash and Cash Equivalents at Beginning of Year	<u>7,702,247</u>
CASH AND CASH EQUIVALENTS AT END OF THE YEAR	<u>\$ 7,406,787</u>
<u>Cash and Cash Equivalents:</u>	
<u>Financial Statement Classification:</u>	
Cash and cash equivalents	\$ 6,776,783
Restricted cash and cash equivalents	630,004
Total Cash and Cash Equivalents	<u>\$ 7,406,787</u>

(Continued)

The accompanying notes are an integral part of the financial statements.

**SAN ELIJO JOINT POWERS AUTHORITY
STATEMENT OF CASH FLOWS (CONTINUED)
FOR THE YEAR ENDED JUNE 30, 2015**

Reconciliation of Operating Loss to

Net Cash Provided by Operating Activities:

Operating loss	\$ (290,798)
----------------	--------------

**Adjustments to reconcile operating loss to
net cash provided by operating activities:**

Depreciation and amortization	1,831,903
-------------------------------	-----------

Change in assets and liabilities:

Due from other government agencies	105,531
Prepaid expenses	(2,782)
Deferred outflows related to contributions	(11,609)
Deferred outflows related to pensions	(4,744)
Accounts payable	16,071
Accrued liabilities	32,362
Due to other government agencies	(161,390)
Net pension liability	(580,094)
Net OPEB obligation	35,275
Compensated absences	13,300
Deferred inflows related to pensions	615,572
Net Cash Provided by Operating Activities	<u>\$ 1,598,597</u>

Supplemental Disclosure of Cash Flow Information:

Capital assets acquired with retention payable	\$ <u>20,849</u>
Amortization of deferred amount on refunding	\$ <u>41,286</u>

The accompanying notes are an integral part of the financial statements.

SAN ELIJO JOINT POWERS AUTHORITY
NOTES TO FINANCIAL STATEMENTS
JUNE 30, 2015

Note 1 - Organization and Significant Accounting Policies:

Organization

The San Elijo Joint Powers Authority (SEJPA) was established on June 17, 1987 with the power to own, operate, maintain and upgrade the San Elijo Water Reclamation Facility (WRF) through an agreement between the Cardiff Sanitation District (Cardiff) and the Solana Beach Sanitation District (Solana Beach)(the member agencies). The SEJPA which is governed by a board consisting of four members, two from each member agency; serves as a wastewater treatment facility for the member agencies as well as portions of Rancho Santa Fe Community Services District, Improvement Areas 2 and 3, and portions of the City of San Diego. On July 1, 1990, the City of Solana Beach succeeded to the powers and responsibilities of the Solana Beach Sanitation District; and on October 18, 2001, the City of Encinitas succeeded to the powers and responsibilities of the Cardiff Sanitation District.

Under the agreement establishing the SEJPA, Cardiff retained its right to 56% of the available treatment capacity of the plant, and Solana Beach retained its right to the remaining 44%. In May 1989 through an agreement between the SEJPA and the member agencies to upgrade and expand the WRF; Solana Beach paid Cardiff to increase its ownership percentage and capacity rights to 50%.

The SEJPA and the City of Escondido are joint owners and users, 21% and 79% respectively, of the San Elijo Ocean Outfall which is generally comprised of a regulator station and piping extending from an on-shore location out into the ocean.

The criteria used in determining the scope of the reporting entity is based on the provisions of GASB Cod. Sec. 2100 "Defining the Financial Reporting Entity". The SEJPA is the primary government unit. Component units are those entities which are financially accountable to the primary government, either because the SEJPA appoints a voting majority of the component units board, or because the component unit will provide a financial benefit or impose a financial burden on the SEJPA. The SEJPA has no component units.

Significant Accounting Policies

A summary of the SEJPA's significant accounting policies consistently applied in the preparation of the accompanying financial statements follows:

Method of Accounting

The SEJPA utilizes accounting principles appropriate for an enterprise fund to record its activities. Accordingly the statement of net position and the statement of revenues, expenses, and changes in net position have been prepared using the economic resources measurement focus and the accrual basis of accounting.

The SEJPA has not elected to apply the option allowed in GASB Cod. Sec. P80.103 "Proprietary Fund Accounting and Financial Reporting" and, as a consequence, will continue to apply GASB statements and interpretations.

SAN ELIJO JOINT POWERS AUTHORITY
NOTES TO FINANCIAL STATEMENTS
JUNE 30, 2015

Note 1 - Organization and Accounting Policies: (Continued)

Estimates

The preparation of financial statements in conformity with accounting principles generally accepted in the United States of America requires management to make estimates and assumptions that affect the reported amounts of assets, deferred outflows of resources, liabilities and deferred inflows of resources and disclosure of contingent assets and liabilities at the date of the financial statements and the reported amounts of revenues and expenses during the reporting period. Actual results could differ from those estimates.

Revenue Recognition

The SEJPA recognizes revenue from charges for services to other government agencies and contributions from its members when they are earned. Operating activities generally result from providing services and producing and delivering goods. As such, the SEJPA considers charges for services to other government agencies and contributions from the cities to be operating revenues.

Investments

Investments are stated at their fair value which represents the quoted or stated market value. Investments that are not traded on a market, such as investments in external pools, are valued based on the stated fair value as represented by the external pool.

Allowance for Doubtful Accounts

Bad debts are recognized on the allowance method based on historical experience and management's evaluation of outstanding receivables. Management believes that all amounts due from other government agencies, loans receivable and the retrofit loans receivable were fully collectible; therefore no allowance for doubtful accounts was recorded at June 30, 2015.

Capital Assets

Capital assets purchased or acquired with a cost exceeding \$2,000 and an estimated useful life of more than one year are reported at historical cost. Contributed assets are recorded at fair market value as of the date received. Additions, improvements and other capital outlays that significantly extend the useful life of an asset are capitalized. Other costs incurred for repairs and maintenance are expensed as incurred. Depreciation is calculated on the straight-line method over the following estimated useful lives:

Plant equipment	5 - 50 years
Lab equipment	5 - 40 years
Office equipment	5 - 20 years
Vehicles	5 years

Depreciation totaled \$1,826,804 for the year ended June 30, 2015.

SAN ELIJO JOINT POWERS AUTHORITY
NOTES TO FINANCIAL STATEMENTS
JUNE 30, 2015

Note 1 - Organization and Accounting Policies: (Continued)

Significant Accounting Policies (Continued)

Interest

The SEJPA incurred interest charges on long-term debt. No interest was capitalized as a cost of construction for the year ended June 30, 2015.

Amortization

Bond insurance costs are being amortized on the straight-line method over periods not to exceed the debt maturities. Amortization expense totaled \$5,099 for the year ended June 30, 2015.

The original issue premium is being amortized on the straight-line method over the remaining life of the related debt. Amortization of the original issue premium totaled \$79,847 for the year ended June 30, 2015 and is included in interest expense.

The deferred amount on refunding is being amortized over the remaining life of the refunded debt. Amortization expense totaled \$41,826 for the year ended June 30, 2015, and is included in interest expense.

Classification of Liabilities

Certain liabilities which are currently payable have been classified as noncurrent because they will be funded from restricted assets.

Compensated Absences

Accumulated and unpaid vacation and sick-leave totaling \$343,953 is accrued when incurred and included in noncurrent liabilities at June 30, 2015.

Deferred Outflows of Resources and Deferred Inflows of Resources

Deferred outflows of resources and deferred inflows of resources are defined as a consumption of net assets by the government that is applicable to a future period and an acquisition of net assets by the government that is applicable to a future reporting period respectively. Deferred outflows of resources include a deferred amount on refunding. Deferred outflows of resources and deferred inflows of resources related to pensions are more fully described in Note 14.

Risk Management

The SEJPA is a member of the California Sanitation Risk Management Authority (CSRMA). CSRMA is a risk-pooling self-insurance authority created under provisions of California Government Code Sections 6500 et. seq. The purpose of CSRMA is to arrange and administer programs of insurance for the pooling of self-insured losses and to purchase excess insurance coverage. Each insured agency pays for its proportionate share of its individually contracted insurance coverage and consulting services. At June 30, 2015, the SEJPA participated in the programs of CSRMA as follows:

SAN ELIJO JOINT POWERS AUTHORITY
NOTES TO FINANCIAL STATEMENTS
JUNE 30, 2015

Note 1 - Organization and Accounting Policies: (Continued)

Significant Accounting Policies (Continued)

Risk Management (Continued)

General Liability including Bodily Injury, Property Damage, Public Entity Errors and Omissions, Employment Practices Liability and Automobile Liability - The CSRMA Pooled Liability (shared risk) Program provides \$25,500,000 per occurrence and in aggregate. CSRMA is self-insured up to \$15,500,000 and additional \$10,000,000 in excess insurance has been purchased to bring the total limit of liability coverage to \$25,500,000. SEJPA has a \$100,000 deductible in the CSRMA Pooled Liability Program.

Property Damage - \$56,191,022 in scheduled values through the APIP Property Program with a \$1,000,000,000 shared loss limit per occurrence with a \$5,000 deductible. Coverage includes: all risk property coverage, mobile equipment, auto physical damage and boiler and machinery. The SEJPA has a \$5,000 to \$350,000 deductible for boiler and machinery coverage depending on the size of the machinery.

Faithful Performance/Employee Dishonesty Bond - Insured up to \$2,000,000 with a \$2,500 deductible. Coverage includes: employee dishonesty, faithful performance forgery or alteration, computer fraud, money and securities theft, disappearance and destruction.

Workers' Compensation - SEJPA participates in CSRMA's Workers' Compensation Program, which currently self-insures the first \$750,000 of each claim. The members have no deductible or self-insured retention. Excess insurance provides statutory limits for Workers' Compensation and \$750,000 for each accident or each employee for disease in limits for Employers Liability.

The SEJPA pays annual premiums for this coverage. They are subject to retrospective adjustments based on claims experienced. The nature and amounts of the adjustments cannot be estimated and are charged to expense as invoiced. The SEJPA's insurance expense totaled \$56,275 for the year ended June 30, 2015. There were no instances in the past three years where a settlement exceeded the SEJPA's coverage.

Pensions

For purposes of measuring the net pension liability, deferred outflows of resources and deferred inflows of resources related to pensions, and pension expense, information about the fiduciary net position and additions to/deductions from the Plan's fiduciary net position have been determined on the same basis as they are reported by CalPERS. For this purpose, benefit payments (including refunds of employee contributions) are recognized when due and payable in accordance with the benefit terms. Investments are reported at fair value. CalPERS audited financial statements are publicly available reports that can be obtained at CalPERS website.

Economic Dependency

The SEJPA received approximately 47% of its operating revenues from its member agencies for the year ended June 30, 2015.

**SAN ELIJO JOINT POWERS AUTHORITY
NOTES TO FINANCIAL STATEMENTS
JUNE 30, 2015**

Note 1 - Organization and Accounting Policies: (Continued)

Significant Accounting Policies (Continued)

Cash and Cash Equivalents

For purposes of the statement of cash flows the SEJPA considers all investment instruments purchased with a maturity of three months or less to be cash equivalents.

Subsequent Events

In preparing these financial statements, the SEJPA has evaluated events and transactions for potential recognition or disclosure through October __, 2015, the date the financial statements were available to be issued.

Note 2 - Cash and Cash Equivalents:

Investments Authorized by the California Government Code and the SEJPA's Investment Policy

The table below identifies the investment types that are authorized for the SEJPA by the California Government Code. The table also identifies certain provisions of the California Government Code that address interest rate risk, and concentration of credit risk. This table does not address investments of debt proceeds held by bond trustees that are governed by the provisions of debt agreements of the SEJPA, rather than the general provision of the California Government Code or the SEJPA's investment policy:

<u>Authorized Investment Type</u>	<u>Maximum Maturity</u>	<u>Maximum Percentage of Portfolio</u>	<u>Quality Requirements</u>
Local Agency Bonds	5 years	None	None
U.S. Treasury Obligations	5 years	None	None
State Obligations	5 years	None	None
CA Local Agency Obligations	5 years	None	None
U.S. Agency Securities	5 years	None	None
Bankers Acceptances	180 days	40%	None
Commercial Paper	270 days	25%	A1
Negotiable Certificates of Deposit	5 years	30%	None
Repurchase Agreements	1 year	None	None
Reverse Repurchase Agreements	92 days	20%	None
Medium-Term Notes	5 years	30%	A Rating
Mutual Funds	N/A	20%	Multiple
Money Market Mutual Funds	N/A	20%	Multiple
Collateralized Bank Deposits	5 years	None	None
Mortgage Pass-Through Securities	5 years	20%	AA Rating
Time Deposits	5 years	None	None
California Local Agency Investment Fund (LAIF)	N/A	None	None
County Pooled Investments	N/A	None	None

**SAN ELIJO JOINT POWERS AUTHORITY
NOTES TO FINANCIAL STATEMENTS
JUNE 30, 2015**

Note 2 - Cash and Cash Equivalents: (Continued)

Investments Authorized by the California Government Code and the SEJPA's Investment Policy (Continue)

The SEJPA's Investment Policy is more restrictive than the California Government Code. The SEJPA may invest in the California Local Agency Investment Fund and the San Diego County Pooled Money Investment account. Open ended money market mutual funds are being held by the bond trustee.

Cash and cash equivalents held by the SEJPA were comprised of the following at June 30, 2015:

	Maturity in Years		Total
	1 Year or Less		
Cash on hand	\$ 200		\$ 200
California Local Agency Investment Fund (LAIF)	7,356,518		7,356,518
Deposits with financial institutions	50,065		50,065
Open ended money market mutual funds	4		4
Total Cash and Cash Equivalents	\$ 7,406,787		7,406,787
 Financial Statement Classification:			
Current:			
Cash and cash equivalents			\$ 6,776,783
Restricted:			
Cash and cash equivalents			630,004
Total Cash and Investments			\$ 7,406,787

Disclosures Relating to Interest Rate Risk

Interest rate risk is the risk that changes in market interest rates will adversely affect the fair value of an investment. Generally, the longer the maturity of an investment, the greater the sensitivity of its fair value to changes in market interest rates. The SEJPA manages its exposure to interest rate risk by purchasing shorter term investments so that a portion of the portfolio is maturing over time as necessary to provide the cash flows and liquidity needed for operations.

Information about the sensitivity of the fair values of the SEJPA's investments (including investments held by the bond trustee) to market interest rate fluctuations is provided in the previous table that shows the distribution of the SEJPA's investments by maturity at June 30, 2015.

**SAN ELIJO JOINT POWERS AUTHORITY
NOTES TO FINANCIAL STATEMENTS
JUNE 30, 2015**

Note 2 - Cash and Cash Equivalents: (Continued)

Disclosures Relating to Credit Risk

Generally, credit risk is the risk that an issuer of an investment will not fulfill its obligation to the holder of the investment. This is measured by the assignment of a rating by a nationally recognized statistical rating organization. Presented below is the actual rating as of the year end for each investment type:

	<u>Rating as of Year End Standard & Poor's</u>
Open Ended Money Market Mutual Funds	Not Rated
California Local Agency Investment Fund	Not Rated

Concentration of Credit Risk

Concentration of credit is the risk of loss attributed to the magnitude to the SEJPA's investment in a single issue.

The investment policy of the SEJPA contains no limitations on the amount that can be invested in any one issuer beyond that stipulated by the California Government Code. The SEJPA holds no investments in any one issuer (other than U.S. Treasury securities, mutual funds, and external investment pools) that represent 5% or more of the SEJPA's total investments at June 30, 2015.

Custodial Credit Risk

Custodial credit risk for deposits is the risk that, in the event of the failure of a depository financial institution, the SEJPA will not be able to recover its deposits or will not be able to recover collateral securities that are in the possession of an outside party. The custodial credit risk for investments is the risk that, in the event of the failure of the counter-party (e.g., broker-dealer) the SEJPA will not be able to recover the value of its investment or collateral securities that are in the possession of another party. The California Government Code and the SEJPA's investment policy do not contain legal or policy requirements that would limit the exposure to custodial credit risk for deposits or investments, other than the following provision for deposits: The California Government Code requires that a financial institution secure deposits made by state or local governmental units by pledging securities in an undivided collateral pool held by a depository regulated under state law (unless so waived by the governmental unit). The market value of the pledged securities in the collateral pool must equal at least 110% of the total amount deposited by the public agencies. California law also allows financial institutions to secure SEJPA deposits by pledging first trust deed mortgage notes having a value of 150% of the secured public deposits.

At June 30, 2015, none of the SEJPA's deposits with financial institutions in excess of federal depository insurance limits were held in uncollateralized accounts. At June 30, 2015, no SEJPA investments were held by the same broker-dealer (counterparty) that was used by the SEJPA to buy the securities.

**SAN ELIJO JOINT POWERS AUTHORITY
NOTES TO FINANCIAL STATEMENTS
JUNE 30, 2015**

Note 2 - Cash and Cash Equivalents: (Continued)

Investment in State Investment Pool

The SEJPA is a voluntary participant in the Local Agency Investment Fund (LAIF) that is regulated by California Government Code under the oversight of the Treasurer of the State of California. The fair value of the SEJPA's investment in this pool is reported in the accompanying financial statements at amounts based upon the SEJPA's pro-rata share of the fair value provided by LAIF for the entire LAIF portfolio (in relation to the amortized cost of that portfolio). The balance available for withdrawal is based on the accounting records maintained by LAIF, which are recorded on an amortized cost basis.

The statement of cash flows has been prepared by considering all investment instruments purchased with a maturity of three months or less to be cash equivalents. Following is a detail at June 30, 2015:

California Local Agency Investment Fund (LAIF)	\$ 7,356,518
Deposits with financial institutions	50,065
Open ended money market mutual funds	4
Cash on hand	200
Total	\$ 7,406,787

Note 3 - Due From Other Government Agencies:

The SEJPA provides reclaimed water and wastewater treatment to a variety of governmental agencies within San Diego County. The following is a detail of amounts owed to/from the SEJPA by these agencies at June 30, 2015:

City of Solana Beach	\$ 436,977
San Dieguito Water District	95,856
Santa Fe Irrigation District	86,893
City of Del Mar	83,701
San Diego County Water Authority	77,940
Rancho Santa Fe CSD No. 2 and No. 3	72,237
Olivenhain Municipal Water District	19,047
Other	3,422
Encinitas Ranch Golf Course	(59,256)
City of Escondido	(77,198)
City of Encinitas	(145,852)
Total	\$ 593,767

Financial Statement Classification:

Due from other government agencies	\$ 593,767
------------------------------------	------------

**SAN ELIJO JOINT POWERS AUTHORITY
NOTES TO FINANCIAL STATEMENTS
JUNE 30, 2015**

Note 4 - Restricted Assets:

Restricted assets were provided by and are to be used for the following at June 30, 2015:

<u>Funding Source</u>	<u>Use</u>	
Receipts from customers	State loan reserve requirement	\$ 630,000
Debt proceeds and interest earned	Debt service - Solana Beach	1
Debt proceeds and interest earned	Debt service - Encinitas	3
		<u>\$ 630,004</u>

When both restricted and unrestricted resources are available for use, it is the SEJPA's policy to use restricted resources first, and then unrestricted resources as necessary.

Note 5 - Loans Receivable:

The City of Encinitas and the City of Solana Beach have entered into the third amendment and restated loan agreements with the SEJPA. The loans bear interest from 2% to 4%. Principal and interest are payable semi-annually four days prior to each September 1 and March 1 of each year, in order to provide the SEJPA with sufficient funds to service the debt on the Refunding Revenue Bonds (See Note 9). Loans receivable consist of the following at June 30, 2015:

City of Solana Beach	\$ 2,957,581
City of Encinitas	2,627,419
Subtotal	<u>5,585,000</u>
Less current portion	(1,265,000)
Total	<u>\$ 4,320,000</u>

Note 6 - Retrofit Loans Receivable:

The SEJPA has entered into agreements with certain reclaimed water users whereby the SEJPA reimbursed the reclaimed water users for reasonable costs incurred for the retrofitting of the water user's facilities in order for them to accept and use reclaimed water for nonpotable purposes. The water users agreed to repay the SEJPA the aggregate amount of the retrofit work together with interest ranging from 3.5% to 4.5%. Reclaimed water is purchased at the potable water rate with the difference between the two rates being considered repayment of the reimbursed costs with the payment first applied to interest. Retrofit loans receivable consist of the following at June 30, 2015:

22 nd District Agricultural Association	\$ 47,192
Oak Crest Park	3,352
Cardiff Cove Homeowners Association	2,100
Total	<u>\$ 52,644</u>

SAN ELIJO JOINT POWERS AUTHORITY
NOTES TO FINANCIAL STATEMENTS
JUNE 30, 2015

Note 7 - Capital Assets:

Capital assets consist of the following at June 30, 2015:

	<u>Balance at June 30, 2014</u>	<u>Additions</u>	<u>Deletions</u>	<u>Balance at June 30, 2015</u>
Capital Assets Not Being Depreciated:				
Construction in progress	\$ 446,311	\$ 1,860,165	\$ (1,182,070)	\$ 1,124,406
Capital Assets Being Depreciated:				
Plant equipment	66,699,808	1,296,438	(163,498)	67,832,748
Lab equipment	130,340	-	(20,046)	110,294
Office equipment	117,476	-	(37,690)	79,786
Vehicles	302,543	23,760	(37,016)	289,287
Total Capital Assets Being Depreciated	67,250,167	1,320,198	(258,250)	68,312,115
Less: Accumulated depreciation	(28,088,662)	(1,826,804)	257,359	(29,658,107)
Net Capital Assets Being Depreciated	39,161,505	(506,606)	(891)	38,654,008
Net Capital Assets	\$ 39,607,816	\$ 1,353,559	\$ (1,182,961)	\$ 39,778,414

Note 8 - Noncurrent Liabilities:

Noncurrent liabilities consist of the following at June 30, 2015:

	<u>Balance at June 30, 2014</u>	<u>Additions</u>	<u>Deletions</u>	<u>Balance at June 30, 2015</u>	<u>Due within one year</u>	<u>Due After One year</u>
Payable from Restricted Assets:						
Due to member agencies payable from restricted assets	\$ 4	\$ -	\$ -	\$ 4	\$ -	\$ 4
Long-Term Debt:						
Refunding Revenue Bonds (Note 9)	6,820,000	-	(1,235,000)	5,585,000	1,265,000	4,320,000
Original issue premium	459,123	-	(79,847)	379,276	-	379,276
Subtotal	7,279,123	-	(1,314,847)	5,964,276	1,265,000	4,699,276
State loan payable (Note 10)	5,299,679	-	(702,183)	4,597,496	719,738	3,877,758
Private placement loan payable (Note 11)	1,830,216	-	(72,948)	1,757,268	76,007	1,681,261
SFID Reimbursement Agreement payable (Note 12)	463,815	-	(10,322)	453,493	-	453,493
Total Long-Term Debt	14,872,833	-	(2,100,300)	12,772,533	2,060,745	10,711,788
Other Noncurrent Liabilities:						
Net pension liability	2,517,730	288,149	(868,243)	1,937,636	-	1,937,636
Net OPEB obligation (Note 13)	102,263	42,415	(7,140)	137,538	-	137,538
Compensated absences (Note 1)	330,653	170,831	(157,531)	343,953	-	343,953
Total Other Noncurrent Liabilities	2,950,646	501,395	1,032,914	2,419,127	-	2,419,127
Total Noncurrent Liabilities	\$ 17,823,483	\$ 501,395	\$ (3,133,214)	\$ 15,191,664	\$ 2,060,745	\$ 13,130,919

**SAN ELIJO JOINT POWERS AUTHORITY
NOTES TO FINANCIAL STATEMENTS
JUNE 30, 2015**

Note 9 - Refunding Revenue Bonds:

In December 2011, the SEJPA issued the 2011 Revenue Refunding Bonds in the amount of \$9,235,000 for the purpose of refunding its 2003 Refunding Revenue Bonds and prepaying a note to the California Energy Commission. The 2003 Refunding Revenue Bonds had been issued to refund the 1993 Refunding Revenue Bonds, the proceeds of which had been loaned to its two member agencies to finance the upgrade and expansion of the water pollution control facility.

Although the refunding resulted in a deferred amount on refunding of \$340,611, the SEJPA in effect reduced the aggregate debt service payments by approximately \$222,000 each year over the next seven years and obtained an economic gain (difference between the present values of the old debt and the new debt service payments) of \$1,251,450. The deferred amount on refunding totaled \$196,130 at June 30, 2015.

The 2011 Refunding Revenue Bonds are payable in annual principal installments ranging from \$50,000 to \$1,415,000 through March 1, 2021. Interest payments are due semiannually on September 1, and March 1. Interest rates on the bonds range from 2% to 4%. The 2011 Refunding Revenue Bonds outstanding total \$5,585,000 at June 30, 2015. Accrued interest totaled \$69,273 at June 30, 2015. The member agencies have covenanted to make payments of loan installments in each year from net revenues derived from the operation of each Agency's respective wastewater collection system.

Debt service requirements on the Refunding Revenue Bonds are as follows:

Years Ended <u>June 30</u>	<u>Principal</u>	<u>Interest</u>
2016	\$ 1,265,000	\$ 207,817
2017	1,305,000	169,867
2018	1,365,000	117,668
2019	1,415,000	63,068
2020	115,000	6,468
2021	120,000	3,420
	<u>\$ 5,585,000</u>	<u>\$ 568,308</u>

Note 10 - State Loan Payable:

In March 1998, the SEJPA entered into an agreement with the State Water Resources Control Board for funding of the San Elijo Water Reclamation System. The loan was funded through the State Revolving Fund loan program administered by the State of California in the amount of \$12,633,522. The State Revolving Fund loan program provides funding for water reclamation projects at a reduced interest rate of 2.5%. The state loan payable outstanding totaled \$4,597,496 at June 30, 2015. Accrued interest totaled \$100,570 at June 30, 2015. The San Elijo Water Reclamation Project represented the construction of tertiary treatment, operational storage facilities, effluent pump stations and a reclaimed water distribution system. Annual loan payments are made by the SEJPA in the amount of \$834,675 and continue through August 2020. The SEJPA has agreed to maintain a dedicated source of revenue sufficient to provide reasonable assurance of repayment of the loan.

SAN ELIJO JOINT POWERS AUTHORITY
NOTES TO FINANCIAL STATEMENTS
JUNE 30, 2015

Note 10 - State Loan Payable: (Continued)

The terms of the state loan payable require the SEJPA to place \$63,000 into a reserve fund each year for ten (10) years, beginning with the issuance of the loan. The reserve fund balance was \$630,000 at June 30, 2015 (See Note 4).

Debt service requirements on the State Loan Payable are as follows:

Years Ended <u>June 30</u>	<u>Principal</u>	<u>Interest</u>
2016	\$ 719,738	\$ 114,937
2017	737,731	96,944
2018	756,175	78,500
2019	775,079	59,596
2020	794,456	40,219
2021	814,317	20,358
	<u>\$ 4,597,496</u>	<u>\$ 410,554</u>

Note 11 - Private Placement Loan Payable:

In November 2011, the SEJPA entered into a private placement loan payable with Municipal Finance Corporation in the amount of \$2,000,000 to fund advanced water treatment improvements (Advanced Water Treatment Project) at the San Elijo Water Reclamation Facility. Interest accrues at 4.15% on the unpaid principal balance and is payable in forty (40) semi-annual payments of \$74,077 including principal and interest and continue through December 2031. The private placement loan payable outstanding totaled \$1,757,268 at June 30, 2015. Accrued interest totaled \$6,077 at June 30, 2015. The SEJPA's obligation to pay the loan repayments is a special obligation limited solely to the net revenues as defined in the loan agreement. The SEJPA has covenanted that it will fix, prescribe and collect rates, fees and charges sufficient to generate net revenues at least equal to 115% of the amount of the maximum annual debt service.

Debt service requirements on the private placement loan payable are as follows:

Years Ended <u>June 30</u>	<u>Principal</u>	<u>Interest</u>
2016	\$ 76,007	\$ 75,205
2017	79,194	72,146
2018	82,515	68,959
2019	85,975	65,638
2020	89,580	58,574
2021-2025	507,490	232,276
2026-2030	623,191	117,574
2031-2032	213,316	8,913
	<u>\$ 1,757,268</u>	<u>\$ 699,285</u>

**SAN ELIJO JOINT POWERS AUTHORITY
NOTES TO FINANCIAL STATEMENTS
JUNE 30, 2015**

Note 12 - SFID Reimbursement Agreement Payable:

The Santa Fe Irrigation District (SFID) constructed a reclaimed water distribution pipeline extension of 3,400 linear feet to the SEJPA's reclaimed water distribution system in order to extend SEJPA's existing recycled water distribution system and enable the SFID to serve new reclaimed water customers. SEJPA agreed to reimburse SFID for the cost of design and construction of the extension in the amount of \$526,149 and the SFID agreed to convey ownership of the extension to SEJPA. Under the terms of the agreement, the reimbursement amount shall be increased each July 1st by adding interest at the rate equivalent to the average LAIF rate for the past four quarters, but not less than 1% nor greater than 2.5% calculated on the unpaid monthly balance. SEJPA shall reimburse the SFID at a monthly rate of \$450 per acre foot of recycled water delivered through the extension including water delivered to purveyors other than SFID. In addition, SEJPA made an initial downpayment of \$50,000. SEJPA will further make a lump sum payment of all remaining principal and interest due after completion of the 20th year of this agreement if the average annual delivery volume of the extension from year 13 through year 15 exceeds 50 acre feet annually. Future payments on the SFID reimbursement agreement payable are contingent upon future reclaimed water sales, therefore future maturities have not been estimated and the agreement is considered noncurrent. The SFID reimbursement agreement payable totaled \$453,493 at June 30, 2015.

Note 13 - Postemployment Benefits:

Plan Description

The SEJPA provides medical insurance benefits to eligible retirees in accordance with various labor agreements subject to the SEJPA's vesting schedule. Medical benefits are typically available at age 55 and are only available to those retirees that select CalPERS medical upon the date of retirement. The current maximum contribution by the SEJPA to the retiree is \$122 per month, which is set by CalPERS.

Funding Policy and Annual OPEB Costs

The contribution requirements of the SEJPA are established and may be amended annually by the Board of Directors. The SEJPA's annual other post-employment benefit (OPEB) cost (expense) for the Plan is calculated based on the annual required contribution of the SEJPA (ARC), an amount actuarially determined in accordance with GASB Cod. Sec. P50, "Postemployment Benefits Other Than Pension Benefits - Employer Reporting." The ARC represents a level of funding that, if paid on an ongoing basis, is projected to cover normal costs each year and to amortize any unfunded actuarial liabilities (or funding excess) over a period not to exceed twenty years. The SEJPA's Board of Directors has established a policy of funding the ARC on a pay as you go basis. The current ARC rate is 1.93% of annual covered payroll. The following table shows the components of the SEJPA's annual OPEB cost, the amount actually contributed to the Plan including benefits paid to retirees, and changes in the SEJPA's net OPEB obligation for the year ended June 30, 2015:

SAN ELIJO JOINT POWERS AUTHORITY
NOTES TO FINANCIAL STATEMENTS
JUNE 30, 2015

Note 13 - Postemployment Benefits: (Continued)

Funding Policy and Annual OPEB Costs (Continued)

Annual required contribution	\$ 37,634
Interest on net OPEB obligation	4,782
Adjustment to annual required contribution	-
Annual OPEB cost	42,416
Contributions (including benefits paid)	(7,141)
Increase in net OPEB obligation	35,275
Net OPEB obligation - Beginning of Year	102,263
Net OPEB obligation - End of Year	\$ 137,538

The SEJPA's annual OPEB cost, the percentage of annual OPEB cost contributed to the Plan, and the net OPEB obligation for 2015 and the four preceding years were as follows:

Fiscal Year	Annual OPEB Cost	Percentage of ARC Contributed	Net Pension Obligation
June 30, 2011	\$ 22,275	15.33%	\$ 34,591
June 30, 2012	23,965	16.52%	54,596
June 30, 2013	23,554	19.30%	73,604
June 30, 2014	34,275	16.38%	102,263
June 30, 2015	42,416	16.83%	137,538

Funding Status and Funding Progress

As of June 30, 2014, the most recent actuarial valuation date, the Plan was not yet funded. The SEJPA's actuarial accrued liability for benefits at June 30, 2014 was \$291,746 and the covered payroll (annual payroll of active employees covered by the Plan) was \$1,940,742, with a ratio of the UAAL to the covered payroll of 15.0%. The normal cost payments made during the year of \$7,141 funded 16.83% of the annual required contribution (ARC) leaving an unfunded actuarial liability (UAAL) of \$327,021 and a funded ratio of 0.0%.

Actuarial Valuation Date	Actuarial Value of Assets (A)	Actuarial Liability Entry Age (B)	Unfunded AAL (UAAL) (B-A)	Funded Status (A/B)	Covered Payroll (C)	UAAL as a Percentage of Covered Payroll [(B-A)/C]
June 30, 2011	\$ -	\$ 149,480	\$ 149,880	0.0%	\$ 1,623,768	9.2%
June 30, 2014	-	291,746	291,746	0.0%	1,940,742	15.0%

SAN ELIJO JOINT POWERS AUTHORITY
NOTES TO FINANCIAL STATEMENTS
JUNE 30, 2015

Note 13 - Postemployment Benefits: (Continued)

Funding Status and Funding Progress (Continued)

Actuarial valuations of an ongoing Plan involve estimates of the value of reported amounts and assumptions about the probability of occurrence of events far into the future. Examples include assumptions about future employment, mortality, and the healthcare cost trend. Amounts determined regarding the funded status of the Plan and the annual required contributions of the employer are subject to continual revision as actual results are compared with past expectations and new estimates are made about the future. The schedule of funding progress presents multiyear trend information that shows whether the actuarial value of Plan assets is increasing or decreasing over time relative to the actuarial accrued liabilities for benefits.

Actuarial Methods and Assumptions

Projections of benefits for financial reporting purposes are based on the formal Plan document and include the types of benefits provided at the time of each valuation and the historical pattern of sharing benefits and costs between employer and plan members to that point. The actuarial methods and assumptions used include techniques that are designed to reduce the effects of short-term volatility in actuarial accrued liabilities and the actuarial assets, consistent with the long-term perspective of the calculations.

The actuarial cost method used for determining the benefit obligations is the Entry Age Normal Cost Method. The actuarial assumptions included a 4.0% discount rate, which assumes the SEJPA continues to maintain the retiree health benefits program as an unfunded plan. The amount represents the present value of all contributions for retiree health benefits projected to be paid by the SEJPA for current and future retirees; and an annual healthcare cost trend rate of 3.5%. The UAAL is being amortized as a level percentage of projected payroll over 17 years.

Note 14 - Defined Benefit Pension Plan:

General Information About the Pension Plans

Plan Descriptions - All qualified permanent and probationary employees are eligible to participate in the Miscellaneous Plan of the San Elijo Joint Powers Authority, (All Plans) a cost-sharing multiple employer defined benefit pension plan administered by the California Public Employees' Retirement System (CalPERS). Benefit provisions under the Plans are established by State statute and Local Government resolution. CalPERS issues publicly available reports that include a full description of the pension plan regarding benefit provisions, assumptions and membership information that can be found on the CalPERS website.

**SAN ELIJO JOINT POWERS AUTHORITY
NOTES TO FINANCIAL STATEMENTS
JUNE 30, 2015**

Note 14 - Defined Benefit Pension Plan: (Continued)

General Information About the Pension Plans (Continued)

Benefits Provided - CalPERS provides service retirement and disability benefits, annual cost of living adjustments and death benefits to plan members, who must be public employees and beneficiaries. Benefits are based on years of credited service, equal to one year of full time employment. The SEJPA participates in the miscellaneous 2.5% at 55 pool, for those employees hired before July 1, 2012. New employees with no prior CalPERS membership and those with prior CalPERS membership with a break in service greater than six months, hired after July 1, 2012 participate in the miscellaneous 2% at 62 pool. Employees hired after July 1, 2012 with prior CalPERS membership with less than six months break in service, participate in the miscellaneous 2% at 60 pool.

The Plan's provisions and benefits in effect at June 30, 2015, are summarized as follows:

	Prior to July 1, 2012	Miscellaneous	
		On or After July 1, 2012 Second Tier	PEPRA
Hire date			
Benefit formula	2.5% @ 55	2% @ 60	2% @ 62
Benefit vesting schedule	5 years service	5 years service	5 years service
Benefit payments	Monthly for life	Monthly for life	Monthly for life
Retirement age	50	50 - 63	52 - 67
Monthly benefits, as a % of eligible compensation	2.0% to 2.5%	1.092% to 2.418%	1.0% to 2.5%
Required employee contribution rates	8.00%	7.000%	6.25%
Required employer contribution rates	9.671%	6.709%	6.237%

Contributions - Section 20814(c) of the California Public Employees' Retirement Law requires that the employer contribution rates for all public employers be determined on an annual basis by the actuary and shall be effective on the July 1 following notice of a change in the rate. Funding contributions for the Plans are determined annually on an actuarial basis as of June 30 by CalPERS. The actuarially determined rate is the estimated amount necessary to finance the costs of benefits earned by employees during the year, with an additional amount to finance any unfunded accrued liability. The SEJPA is required to contribute the difference between the actuarially determined rate and the contribution rate of employees.

SAN ELIJO JOINT POWERS AUTHORITY
NOTES TO FINANCIAL STATEMENTS
JUNE 30, 2015

Note 14 - Defined Benefit Pension Plan: (Continued)

Pension Liabilities, Pension Expenses and Deferred Outflow/Inflows of Resources Related to Pensions

As of June 30, 2015, the SEJPA reported net pension liabilities for its proportionate shares of the net pension liability of each Plan as follows:

	Proportionate Share of Net Pension Liability
2.5% @ 55	\$ 1,937,481
2.0% @ 60	133
2.0% @ 62	22
Total Net Pension Liability	\$ 1,937,636

The SEJPA's net pension liability for each plan is measured as the proportionate share of the net pension liability. The net pension liability of each of the Plans is measured as of June 30, 2014, and the total pension liability for each plan used to calculate the net pension liability was determined by an actuarial valuation as of June 30, 2013 rolled forward to June 30 2014 using standard update procedures. The SEJPA's proportion of the net pension liability was based on a projection of the SEJPA's long-term share of contributions to the pension plans relative to the projected contributions of all participating employers, actuarially determined. The SEJPA's proportionate share of the net pension liability for each Plan as of June 2013 and 2014 was as follows:

	2.5% @ 55	2% @ 60	2% @ 62
Proportion - June 30, 2013	N/A	N/A	N/A
Proportion - June 30, 2014	.03114%	-	-
Change - Increase (Decrease)	N/A	N/A	N/A

For the year ended June 30, 2015, the SEJPA recognized pension expense of \$288,149. At June 30, 2015, the SEJPA reported deferred outflows of resources and deferred inflows of resources from the following sources:

	Deferred Outflows of Resources	Deferred Inflows of Resources
Pension contributions subsequent to measurement date	\$ 269,023	\$ -
Change in employer's proportion and differences between the employer's contributions and the employer's proportionate share of contributions	4,744	28,369
Differences between actual and expected experience	-	39,282
Net difference between projected and actual earnings on plan investments	-	547,921
Total	\$ 273,767	\$ 615,572

**SAN ELIJO JOINT POWERS AUTHORITY
NOTES TO FINANCIAL STATEMENTS
JUNE 30, 2015**

Note 14 - Defined Benefit Pension Plan: (Continued)

Pension Liabilities, Pension Expenses and Deferred Outflow/Inflows of Resources Related to Pensions (Continued)

The \$269,023 reported as deferred outflows of resources related to contributions subsequent to the measurement date will be recognized as a reduction of the net pension liability in the year ended June 30, 2016. Other amounts reported as deferred outflows of resources and deferred inflows of resources related to pensions will be recognized as pension expense as follows:

Years Ended June 30	
2016	\$ (159,448)
2017	(159,448)
2018	(154,951)
2019	(136,981)
2020	-
Thereafter	-
Total	<u>\$ (610,828)</u>

Actuarial Assumptions - The total pension liabilities in the June 30, 2013 actuarial valuations were determined using the following actuarial assumptions:

	<u>2.5% @ 55</u>	<u>2% @ 60</u>	<u>2% @ 62</u>
Valuation Date	June 30, 2013	June 30, 2013	June 30, 2013
Measurement Date	June 30, 2014	June 30, 2014	June 30, 2014
Actuarial Cost Method	Entry-Age Cost Method	Entry-Age Cost Method	Entry-Age Cost Method
Actuarial Assumptions:			
Discount Rate	7.5%	7.5%	7.5%
Inflation	2.75%	2.75%	2.75%
Payroll Growth	3.0%	3.0%	3.0%
Projected Salary Increase	3.3% - 14.2%(1)	3.3% - 14.2%(1)	3.3% - 14.2%(1)
Investment Rate of Return	7.5% (2)	7.5% (2)	7.5% (2)
Mortality	CalPERS Specific	CalPERS Specific	CalPERS Specific

(1) Depending on age, service and type of employment

(2) Net of pension plan investment expenses, including inflation

The underlying mortality assumption and all other actuarial assumptions used in the June 30, 2013 valuation were based on the results of a January 2014 actuarial experience study for the period 1997 to 2011. Further details for the Experience Study can be found on the CalPERS website.

**SAN ELIJO JOINT POWERS AUTHORITY
NOTES TO FINANCIAL STATEMENTS
JUNE 30, 2015**

Note 14 - Defined Benefit Pension Plan: (Continued)

Pension Liabilities, Pension Expenses and Deferred Outflow/Inflows of Resources Related to Pensions (Continued)

Actuarial Assumptions (Continued) -The long-term expected rate of return on pension plan investments was determined using a building-block method in which best-estimate ranges of expected future real rates of return (expected returns, net of pension plan investment expense and inflation) are developed for each major asset class.

In determining the long-term expected rate of return, CalPERS took into account both short-term and long-term market return expectations as well as the expected pension fund cash flows. Such cash flows were developed assuming that both members and employers will make their required contributions on time and as scheduled in all future years. Using historical returns of all the funds' asset classes, expected compound (geometric) returns were calculated over the short-term (first 10 years) and the long-term (11-60 years) using a building-block approach. Using the expected nominal returns for both short-term and long-term, the present value of benefits was calculated for each fund. The expected rate of return was set by calculating the single equivalent expected return that arrived at the same present value of benefits for cash flows as the one calculated using both short-term and long-term returns. The expected rate of return was then set equivalent to the single equivalent rate calculated above and rounded down to the nearest one quarter of one percent.

The table below reflects long-term expected real rate of return by asset class. The rate of return was calculated using the capital market assumptions applied to determine the discount rate and asset allocation. These geometric rates of return are net of administrative expenses.

<u>Asset Class</u>	<u>New Strategic Allocation</u>	<u>Real Return Years 1 - 10 (a)</u>	<u>Real Return Years 11 + (b)</u>
Global Equity	47.0%	5.25%	5.71%
Global Fixed Income	19.0%	0.99%	2.43%
Inflation Sensitive	6.0%	0.45%	3.36%
Private Equity	12.0%	6.83%	6.95%
Real Estate	11.0%	4.50%	5.13%
Infrastructure and Forestland	3.0%	4.50%	5.09%
Liquidity	2.0%	(0.55%)	(1.05%)
Total	<u>100.0%</u>		

(a) An expected inflation of 2.5% used for this period.

(b) An expected inflation of 3.0% used for this period.

**SAN ELIJO JOINT POWERS AUTHORITY
NOTES TO FINANCIAL STATEMENTS
JUNE 30, 2015**

Note 14 - Defined Benefit Pension Plan: (Continued)

Pension Liabilities, Pension Expenses and Deferred Outflow/Inflows of Resources Related to Pensions (Continued)

Discount Rate - The discount rate used to measure the total pension liability was 7.50% for each Plan. To determine whether the municipal bond rate should be used in the calculation of a discount rate for each plan, CalPERS stress tested plans that would most likely result in a discount rate that would be different from the actuarially assumed discount rate. Based on the testing, none of the tested plans run out of assets. Therefore, the current 7.50 percent discount rate is adequate and the use of the municipal bond rate calculation is not necessary. The long term expected discount rate of 7.50 percent is applied to all plans in the Public Employees Retirement Fund (PERF). The stress test results are presented in a detailed report called “GASB Crossover Testing Report” that can be obtained from the CalPERS website under the GASB 68 Section.

According to Paragraph 30 of Statement 68, the long-term discount rate should be determined without reduction for pension plan administrative expense. The 7.50 percent investment return assumption used in this accounting valuation is net of administrative expenses. Administrative expenses are assumed to be 15 basis points. An investment return excluding administrative expenses would have been 7.65 percent. Using this lower discount rate has resulted in a slightly higher Total Pension Liability and Net Pension Liability. The difference was deemed immaterial to the Public Agency Cost Sharing Multiple-Employer Defined Benefit Pension Plan.

CalPERS is scheduled to review all actuarial assumptions as part of its regular Asset Liability Management (ALM) review cycle that is scheduled to be completed in February 2018. Any changes to the discount rate will require Board action and proper stakeholder outreach. For these reasons, CalPERS expects to continue using a discount rate net of administrative expenses for GASB 67 and 68 calculations through at least the 2017 - 18 fiscal year. CalPERS will continue to check the materiality of the difference in calculation until such time as they have changed their methodology.

Sensitivity of the Proportionate Share of the Net Pension Liability to Changes in the Discount Rate - The following presents the net pension liability of each Plan, as of the measurement date calculated using the discount rate of 7.5%, as well as what the net pension liability would be if it were calculated using a discount rate that is 1-percentage point lower or 1-percentage point higher than the current rate:

	<u>2.0% @ 60</u>	<u>2.0% @ 62</u>	<u>2.5% @ 55</u>
1% Decrease Net Pension Liability	\$ 6.5% 237	\$ 6.5% 40	\$ 6.5% 3,252,647
Current Discount Rate Net Pension Liability	\$ 7.5% 133	\$ 7.5% 22	\$ 7.5% 1,937,481
1% Increase Net Pension Liability	\$ 8.5% 47	\$ 8.5% 8	\$ 8.5% 846,018

SAN ELIJO JOINT POWERS AUTHORITY
NOTES TO FINANCIAL STATEMENTS
JUNE 30, 2015

Note 14 - Defined Benefit Pension Plan: (Continued)

Pension Plan Fiduciary Net Position - Detailed information about each pension plan's fiduciary net position is available in the separately issued CalPERS financial reports.

Payable to the Pension Plan

At June 30, 2015, the SEJPA reported a payable of \$-0- for the outstanding amount of contributions to the pension plan required for the year ended June 30, 2015.

Note 15 - Commitments and Contingencies:

Contracts

The SEJPA has entered into various contracts for the purchase of material and construction of capital assets. The amounts contracted are based on the contractor's estimated cost of construction. At June 30, 2015, the total unpaid amount on these contracts is approximately \$366,398.

Litigation

Legal claims and lawsuits arise from time to time in the normal course of business which, in the opinion of management, will have no material effect on the SEJPA's financial position.

Operating Leases

Under an agreement dated April 11, 1991 the SEJPA leases a maintenance facility to the City of Encinitas for \$1 per year for an initial term of 30 years. The lease may be renewed or extended at the expiration of the initial term at a rate mutually agreed upon. In addition to the annual payment of \$1, the City agreed to reimburse the SEJPA within 30 days for all engineering and inspection costs incurred as a result of the engineering and construction of the maintenance facility. The City also agreed to reimburse the SEJPA for all construction costs incurred by the SEJPA as a result of the construction of the maintenance facility in 30 equal annual installments at an interest rate equal to the interest rate on the bonds issued for construction of the upgrade and expansion of the Water Pollution Control Facility. The lease payments collected are then remitted directly to the member agencies.

SAN ELIJO JOINT POWERS AUTHORITY
NOTES TO FINANCIAL STATEMENTS
JUNE 30, 2015

Note 15 - Commitments and Contingencies: (Continued)

Operating Leases (Continued)

In January 2007 the SEJPA entered into a Communications Site License Agreement as lessor with Omnipoint Communications, Inc. which was subsequently conveyed to T-Mobile West, LLC. The initial term of the agreement, which calls for an annual payment of \$20,400 and increasing 3% annually, is for 5 years commencing the earlier of the date the licensees intend to commence construction or October 1, 2007. This lease agreement may be extended automatically for five additional five-year terms on the same terms and conditions at the election of Omnipoint. The lease is currently extended through October 1, 2017. The SEJPA recognized rental income in the amount of \$25,091 for the year ended June 30, 2015.

Note 16 - New Governmental Accounting Standards:

GASB No. 68

In June 2012, the Governmental Accounting Standards Board issued Statement No. 68, "Accounting and Financial Reporting for Pensions". This pronouncement is effective for periods beginning after June 15, 2014. This pronouncement establishes accounting and financial reporting requirements related to pensions for governments whose employees are provided with pensions through pension plans, as well as for nonemployer governments that have a legal obligation to contribute to those plans. The effects of this pronouncement on the financial statements of the SEJPA in the year of implementation are more fully described in Note 17.

GASB No. 69

In January 2013, The Governmental Accounting Standard Board issued Statement No. 69, "Government Combinations and Disposals of Government Operations." This pronouncement is effective for government combinations and disposals of government operations occurring in financial reporting periods beginning after December 15, 2014 and should be applied on a prospective basis. Earlier application is encouraged. This statement requires the use of carrying values to measure the assets and liabilities in a government merger. Conversely, this statement requires measurements of assets acquired and liabilities assumed generally to be based upon their acquisition values. This statement also provides guidance for transfers of operations that do not constitute entire legally separate entities and in which no significant consideration is exchanged. This statement provides accounting and financial reporting guidance for disposals of government operations that have been transferred or sold. This pronouncement did not have a material effect on the financial statements of the SEJPA in the year of implementation.

SAN ELIJO JOINT POWERS AUTHORITY
NOTES TO FINANCIAL STATEMENTS
JUNE 30, 2015

Note 16 - New Governmental Accounting Standards: (Continued)

GASB No. 70

In April 2013, The Governmental Accounting Standard Board issued Statement No. 70, “Accounting and Financial Reporting for Nonexchange Financial Guarantees.” This pronouncement is effective for financial reporting periods beginning after June 15, 2014. Earlier application is encouraged. This statement requires a government that extends a nonexchange financial guarantee to recognize a liability when qualitative factors and historical data indicate that the government will be required to make a payment on the guarantee. The Government that issued the obligation guaranteed in a nonexchange transaction should recognize revenue to the extent that its guaranteed obligations have been reduced. If that government is required to repay a guarantor for making a payment, they should continue to reflect the liability until legally released as an obligor. The SEJPA has not extended any nonexchange financial guarantees at the date of these financial statements.

GASB No. 71

In November 2013, The Governmental Accounting Standards Board issue Statement No. 71, “Pension Transition for Contributions Made Subsequent to the Measurement Date – An Amendment of GASB Statement No. 68. This pronouncement is effective simultaneously with the implementation of Statement 68. This statement amends paragraph 137 of Statement 68 to require that, at transition, a government recognize a beginning deferred outflow of resources for its pension contributions, if any, made subsequent to the measurement date of the beginning net pension liability. The effects of this pronouncement on the financial statements of the SEJPA in the year of implementation are more fully described in Note 17.

GASB No. 72

In February 2015, The Governmental Accounting Standards Board issued Statement No. 72, “Fair Value Measurement and Application.” This pronouncement provides guidance for determining fair value measurement for financial reporting purposes and provides guidance for applying fair value to certain investments and disclosures related to all fair value measurements. Governments are required to use valuation techniques that are appropriate under the circumstances and for which sufficient data is available to measure fair value. Required disclosures include the level of fair value hierarchy and valuation techniques and should be organized by type of asset or liability. This pronouncement is effective for financial statements for periods beginning after June 15, 2015. Earlier application is encouraged. The District has not yet determined the effects of this pronouncement on the financial statements of the District in the year of implementation.

**SAN ELIJO JOINT POWERS AUTHORITY
NOTES TO FINANCIAL STATEMENTS
JUNE 30, 2015**

Note 16 - New Governmental Accounting Standards: (Continued)

GASB No. 73

In June 2015, The Governmental Accounting Standards Board issued Statement No. 73, “Accounting and Financial Reporting for Pensions and Related Assets That Are Not within the Scope of GASB Statement 68, and Amendments to Certain Provisions of GASB Statements 67 and 68.” This pronouncement establishes requirements for defined benefit pension plans that are not with the scope of Statement No. 68, as well as assets accumulated for purposes of providing those pensions. It establishes requirements for defined contribution pension plans that are not within the scope of Statement No. 68 and amends certain provisions of Statement No. 67. The pronouncement extends the approach to accounting and financial reporting established in Statement 68 to all pensions with modifications as necessary to reflect that for accounting and financial reporting purposes, any assets accumulated for pensions that are provided through pension plans that are not administered through trusts that meet the criteria specified in Statement 68 should not be considered pension plan assets. It also requires that information similar to that required by Statement 68 be included in the notes and required supplementary information by all similarly situated employers and nonemployer contributing entities. The requirements of this statement addressing accounting and financial reporting for employers that are not within the scope of GASB 68 are effective for financial statements for fiscal years beginning after June 15, 2016. All other provisions are effective for periods beginning after June 15, 2015. This pronouncement is not anticipated to have a material effect on the financial statements of the District.

Note 17 - Change in Accounting Principle:

Effective July 1, 2014, the SEJPA changed its method of accounting for retirement expense and the related pension liability as well any deferred inflows of resources and deferred outflows of resources in order to conform with Governmental Accounting Standards Board Statement No. 68, “Accounting and Financial Reporting for Pensions”, as amended by Governmental Accounting Standards Board Statement No. 71, “Pension Transition for Contributions Made Subsequent to the Measurement Date”.

This Statement requires cost-sharing employers such as the SEJPA to recognize a liability for its proportionate share of the net pension liability (of all employers for benefits provided through the plan) – the collective net pension liability. A cost-sharing employer is required to recognize pension expense and report deferred outflows of resources and deferred inflows of resources related to pensions for its proportionate share of collective pension expense and collective deferred outflows of resources and deferred inflows of resources related to pensions. Employer contributions to the pension plan subsequent to the measurement date of the collective net pension liability are also required to be reported as deferred outflows related to pensions. As a result, the District established the following net pension liability and deferred outflow of resources resulting in a reduction in net position reported at June 30, 2014:

Net pension liability	\$ (2,517,730)
Deferred outflows related to contributions	257,414
Net Effect of a Change in Accounting Principle	<u>(2,260,316)</u>
 Net Position as Originally Stated	 <u>39,375,512</u>
 Net Position as Restated	 <u>\$ 37,115,196</u>

**SAN ELIJO JOINT POWERS AUTHORITY
SCHEDULE OF PROPORTIONATE SHARE OF THE NET PENSION LIABILITY
JUNE 30, 2015**

	2014
<u>Miscellaneous Plan:</u>	
SEJPA's proportion of the net pension liability (asset)	0.03114%
SEJPA's proportionate share of the net pension liability (asset)	\$ 1,937,481
SEJPA's covered-employee payroll	\$ 1,568,564
SEJPA's proportionate share of the net pension liability (asset) as a percentage of its covered-employee payroll	123.52%
Plan fiduciary net position as a percentage of the total pension liability	80.46%
<u>Miscellaneous Second Tier Plan:</u>	
SEJPA's proportion of the net pension liability (asset)	0.00000%
SEJPA's proportionate share of the net pension liability (asset)	\$ 133
SEJPA's covered-employee payroll	\$ 42,312
SEJPA's proportionate share of the net pension liability (asset) as a percentage of its covered-employee payroll	0.31%
Plan fiduciary net position as a percentage of the total pension liability	82.99%
<u>Miscellaneous PEPRA Plan:</u>	
SEJPA's proportion of the net pension liability (asset)	0.00000%
SEJPA's proportionate share of the net pension liability (asset)	\$ 22
SEJPA's covered-employee payroll	\$ 96,820
SEJPA's proportionate share of the net pension liability (asset) as a percentage of its covered-employee payroll	0.02%
Plan fiduciary net position as a percentage of the total pension liability	83.08%

**SAN ELIJO JOINT POWERS AUTHORITY
SCHEDULE OF PLAN CONTRIBUTIONS
JUNE 30, 2015**

	2014
<u>Miscellaneous Plan:</u>	
Contractually required contribution	\$ 235,844
Contributions in relation to the contractually required contribution	\$ (235,844)
Contribution deficiency (excess)	\$ -
District's covered-employee payroll	\$ 1,568,564
Contributions as a percentage of covered-employee payroll	15.04%

<u>Miscellaneous Second Tier Plan:</u>	
Contractually required contribution	\$ 14,207
Contributions in relation to the contractually required contribution	\$ (14,207)
Contribution deficiency (excess)	\$ -
District's covered-employee payroll	\$ 42,312
Contributions as a percentage of covered-employee payroll	33.58%

<u>Miscellaneous PEPRA Plan:</u>	
Contractually required contribution	\$ 6,181
Contributions in relation to the contractually required contribution	\$ (6,181)
Contribution deficiency (excess)	\$ -
District's covered-employee payroll	\$ 96,820
Contributions as a percentage of covered-employee payroll	6.38%

DRAFT

**SAN ELIJO JOINT POWERS AUTHORITY
COMBINING SCHEDULE OF NET POSITION
JUNE 30, 2015**

ASSETS

	<u>Wastewater</u>	<u>Reclamation</u>	<u>Total</u>
<u>Current Assets:</u>			
Cash and cash equivalents	\$ 5,427,492	\$ 1,349,291	\$ 6,776,783
Due from other government agencies	289,585	304,182	593,767
Accrued interest receivable	72,690	2,219	74,909
Prepaid expenses	14,244	4,782	19,026
Current portion of loan receivable	<u>1,265,000</u>	<u>-</u>	<u>1,265,000</u>
Total Current Assets	<u>7,069,011</u>	<u>1,660,474</u>	<u>8,729,485</u>
<u>Noncurrent Assets:</u>			
<u>Restricted Assets:</u>			
Cash and cash equivalents	<u>4</u>	<u>630,000</u>	<u>630,004</u>
Total Restricted Assets	<u>4</u>	<u>630,000</u>	<u>630,004</u>
Loans Receivable , net of current portion	<u>4,320,000</u>	<u>-</u>	<u>4,320,000</u>
<u>Capital Assets:</u>			
Nondepreciable	339,611	784,795	1,124,406
Depreciable, net of accumulated depreciation	<u>22,293,855</u>	<u>16,360,153</u>	<u>38,654,008</u>
Total Capital Assets	<u>22,633,466</u>	<u>17,144,948</u>	<u>39,778,414</u>
<u>Other Assets:</u>			
Retrofit loan receivable		52,644	52,644
Bond issuance costs	<u>24,217</u>	<u>-</u>	<u>24,217</u>
Total Other Assets	<u>24,217</u>	<u>52,644</u>	<u>76,861</u>
Total Noncurrent Assets	<u>26,977,687</u>	<u>17,827,592</u>	<u>44,805,279</u>
TOTAL ASSETS	<u>34,046,698</u>	<u>19,488,066</u>	<u>53,534,764</u>
<u>DEFERRED OUTFLOWS OF RESOURCES</u>			
Deferred amount on refunding	196,110	-	196,110
Deferred outflows related to contributions	225,869	43,154	269,023
Deferred outflows related to pensions	<u>4,055</u>	<u>689</u>	<u>4,744</u>
Total Deferred Outflows of Resources	<u>426,034</u>	<u>43,843</u>	<u>469,877</u>

SAN ELIJO JOINT POWERS AUTHORITY
COMBINING SCHEDULE OF NET POSITION (CONTINUED)
JUNE 30, 2015

LIABILITIES

	<u>Wastewater</u>	<u>Reclamation</u>	<u>Total</u>
<u>Current Liabilities:</u>			
Accounts payable	\$ 122,525	\$ 49,902	\$ 172,427
Accrued liabilities	45,955	38,667	84,622
Accrued interest payable	69,273	106,647	175,920
Retentions payable	48,802	-	48,802
Current portion of refunding revenue bonds	1,265,000	-	1,265,000
Current portion of state loan payable	-	719,738	719,738
Current portion of private placement loan payable	-	76,007	76,007
Total Current Liabilities	<u>1,551,555</u>	<u>990,961</u>	<u>2,542,516</u>
<u>Noncurrent Liabilities:</u>			
 Payable From Restricted Assets:			
Due to member agencies payable from restricted assets	<u>4</u>	<u>-</u>	<u>4</u>
 Long-Term Debt:			
Refunding revenue bonds, net of current portion	4,699,276	-	4,699,276
State loan payable, net of current portion	-	3,877,758	3,877,758
Private placement loan, net of current portion	-	1,681,261	1,681,261
SFID reimbursement agreement payable	-	453,493	453,493
Total Long-Term Debt	<u>4,699,276</u>	<u>6,012,512</u>	<u>10,711,788</u>
 Other Noncurrent Liabilities:			
Net pension liability	1,664,040	273,596	1,937,636
Net OPEB obligation	114,586	22,952	137,538
Compensated absences	296,060	47,893	343,953
Total Other Noncurrent Liabilities	<u>2,074,686</u>	<u>344,441</u>	<u>2,419,127</u>
Total Noncurrent Liabilities	<u>6,773,966</u>	<u>6,356,953</u>	<u>13,130,919</u>
Total Liabilities	<u>8,325,521</u>	<u>7,347,914</u>	<u>15,673,435</u>
<u>DEFERRED INFLOWS OF RESOURCES</u>			
Deferred inflows related to pensions	<u>526,212</u>	<u>89,360</u>	<u>615,572</u>
<u>NET POSITION:</u>			
Net investment in capital assets	22,401,498	10,230,044	32,631,542
Restricted	-	630,000	630,000
Unrestricted	3,219,501	1,234,591	4,454,092
Total Net Position	<u>\$ 25,620,999</u>	<u>\$ 12,094,635</u>	<u>\$ 37,715,634</u>

**SAN ELIJO JOINT POWERS AUTHORITY
COMBINING SCHEDULE OF REVENUES, EXPENSES AND
CHANGES IN NET POSITION
FOR THE YEAR ENDED JUNE 30, 2015**

	<u>Wastewater</u>	<u>Reclamation</u>	<u>Total</u>
<u>Operating Revenues:</u>			
Charges for services to other government agencies	\$ 894,418	\$ 2,535,788	\$ 3,430,206
Contributions from City of Encinitas	1,646,210	-	1,646,210
Contributions from City of Solana Beach	1,447,859	-	1,447,859
Total Operating Revenues	<u>3,988,487</u>	<u>2,535,788</u>	<u>6,524,275</u>
<u>Operating Expenses:</u>			
Personnel costs	2,195,777	474,859	2,670,636
Depreciation and amortization	1,251,560	580,343	1,831,903
Utilities	539,541	271,491	811,032
Contracted services	410,697	179,691	590,388
Supplies	191,145	76,348	267,493
Disposal services	208,836	-	208,836
Miscellaneous	98,073	80,468	178,541
Repair parts expense	99,495	19,137	118,632
Permit/purveyor fees	54,537	26,800	81,337
Insurance	39,393	16,882	56,275
Total Operating Expenses	<u>5,089,054</u>	<u>1,726,019</u>	<u>6,815,073</u>
Operating Income (Loss)	<u>(1,100,567)</u>	<u>809,769</u>	<u>(290,798)</u>
<u>Nonoperating Revenues (Expenses):</u>			
Investment income	244,806	10,477	255,283
State Grants	-	98,739	98,739
Rental income	25,091	-	25,091
Other	4,421	-	4,421
Gain on disposal of capital assets	224	-	224
Interest expense	(194,122)	(202,206)	(396,328)
Total Nonoperating Revenues (Expenses)	<u>80,420</u>	<u>(92,990)</u>	<u>(12,570)</u>
Income (Loss) Before Capital Contributions	<u>(1,020,147)</u>	<u>716,779</u>	<u>(303,368)</u>
<u>Capital Contributions:</u>			
Member agency assessments	903,806	-	903,806
Total Capital Contributions	<u>903,806</u>	<u>-</u>	<u>903,806</u>
Change in Net Position	(116,341)	716,779	600,438
Net Position at Beginning of Year, as Restated	<u>25,737,340</u>	<u>11,377,856</u>	<u>37,115,196</u>
NET POSITION AT END OF YEAR	<u>\$ 25,620,999</u>	<u>\$ 12,094,635</u>	<u>\$ 37,715,634</u>

**SAN ELIJO JOINT POWERS AUTHORITY
OPERATING BUDGET COMPARISON SCHEDULE - WASTEWATER
FOR THE YEAR ENDED JUNE 30, 2015**

	<u>Budget</u>	<u>Actual</u>	<u>Variance</u>
<u>Operating Expenses:</u>			
Personnel costs	\$ 2,294,692	\$ 2,195,777	\$ 98,915
Utilities	521,181	539,541	(18,360)
Contracted services	505,904	410,697	95,207
Miscellaneous	97,186	98,073	(887)
Supplies	190,784	191,145	(361)
Repair parts expense	138,350	99,495	38,855
Insurance	43,115	39,393	3,722
Disposal services	205,140	208,836	(3,696)
Permit/purveyor fees	52,688	54,537	(1,849)
Contingency	125,000	-	125,000
Capital outlay	35,000	-	35,000
Total Operating Expenses	<u>4,209,040</u>	<u>3,837,494</u>	<u>371,546</u>
Depreciation and Amortization	-	1,251,560	(1,251,560)
Operating Expenses, Net	<u>\$ 4,209,040</u>	<u>\$ 5,089,054</u>	<u>\$ (880,014)</u>

DRAFT

**SAN ELIJO JOINT POWERS AUTHORITY
OPERATING BUDGET COMPARISON SCHEDULE - RECLAMATION
FOR THE YEAR ENDED JUNE 30, 2015**

	<u>Budget</u>	<u>Actual</u>	<u>Variance</u>
<u>Operating Expenses:</u>			
Personnel costs	\$ 480,050	\$ 474,859	\$ 5,191
Utilities	229,348	271,491	(42,143)
Contracted services	139,670	179,691	(40,021)
Miscellaneous	64,147	80,468	(16,321)
Supplies	104,813	76,348	28,465
Repair parts expense	42,000	19,137	22,863
Insurance	19,000	16,882	2,118
Permit/purveyor fees	30,926	26,800	4,126
Capital outlay	5,000	-	5,000
Total Operating Expenses	<u>1,114,954</u>	<u>1,145,676</u>	<u>(30,722)</u>
Depreciation and Amortization	-	580,343	(580,343)
Operating Expenses, Net	<u>\$ 1,114,954</u>	<u>\$ 1,726,019</u>	<u>\$ (611,065)</u>

DRAFT

SAN ELIJO JOINT POWERS AUTHORITY
MEMORANDUM

November 9, 2015

TO: Board of Directors
San Elijo Joint Powers Authority

FROM: General Manager

SUBJECT: UPDATE ON THE FINAL PROGRAM ENVIRONMENTAL IMPACT REPORT -
NORTH SAN DIEGO REGIONAL RECYCLED WATER PROJECT

RECOMMENDATION

No action required. This memorandum is submitted for information only.

BACKGROUND

The *North San Diego Regional Recycled Water Project* involves development of regional recycled water infrastructure to increase the capacity and connectivity of the recycled water storage and distribution systems of the coalition members and maximize reuse of available wastewater supplies. The project includes replacing potable water uses with recycled water, converting facilities to recycled water service, connecting discrete recycled water systems to one another, increasing water storage capacity, distributing recycled water to effectively meet demands, and implementing advanced water treatment to produce and use potable reuse water within the study area (Figure 1).

The coalition members include:

- Carlsbad Municipal Water District
- City of Escondido
- City of Oceanside
- Leucadia Wastewater District
- Olivenhain Municipal Water District
- Rincon del Diablo Municipal Water District
- San Elijo Joint Powers Authority
- Santa Fe Irrigation District
- Vallecitos Water District
- Vista Irrigation District

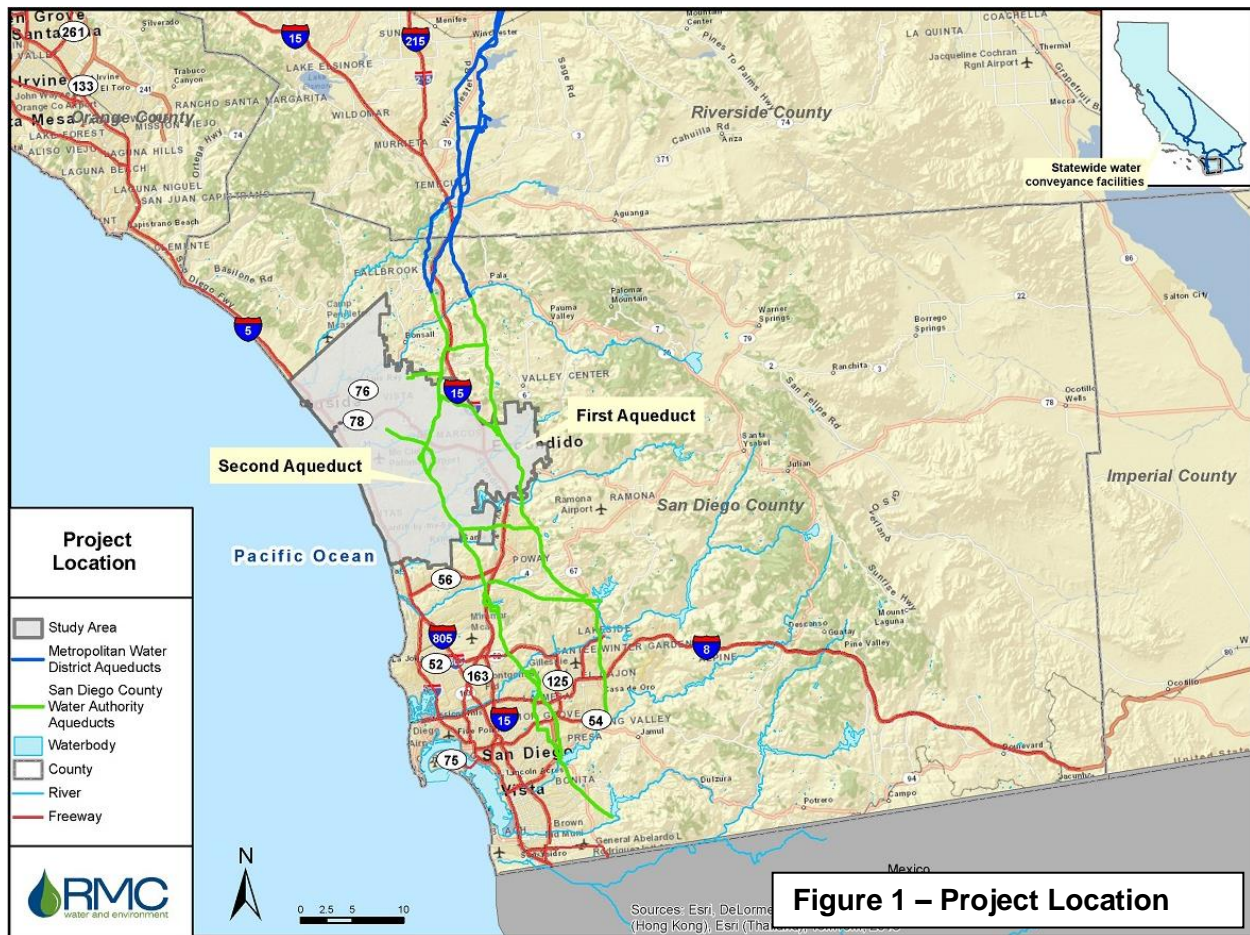

The project components include construction of infrastructure necessary to connect recycled water supplies with demands in a manner that maximizes beneficial reuse within the study area. This infrastructure includes pipelines, new and expanded treatment facilities, pumping stations, storage tanks, and other appurtenances. The project would benefit customers and residents within the study area by increasing recycled water production and use, improving water supply reliability, and reducing treated wastewater discharges to the ocean.

A Draft Program Environmental Impact Report (PEIR) was released on April 6, 2015 for public review by the, Olivenhain Municipal Water District (OMWD), which is acting as the lead agency on the Coalition’s behalf. The public comment period for the Draft PEIR began on April 8, 2015 and ended on June 15, 2015. Public notification of the availability of the Draft PEIR was published in the San Diego Union-Tribune’s North County, Metro, and online editions on April 8, 2015. A public hearing was held before the OMWD Board on May 13, 2015.

Five comment letters were received on the Draft PEIR during the comment period. The Final PEIR includes written responses to all five comment letters received during the comment period, along with clarifications and minor revisions to information presented in the Draft PEIR. No new information was received during the comment period or included in the Final PEIR that required recirculation.

A Final PEIR was released on October 1, 2015 (via print at OMWD’s office and website) and notice of availability of the Final PEIR was transmitted to all five commenters on the same day.

DISCUSSION

Copies of the Final PEIR, Findings of Fact and Statement of Overriding Considerations, and Mitigation Monitoring and Reporting Program (MMRP) can be found at <http://nsdwrc.org/project.html>.

The Final PEIR identifies potentially significant impacts that will be reduced to a less than-significant level with specified mitigation measures for the following resource topics: Aesthetics, Biological Resources, Cultural Resources, Geology and Soils, Hazards and Hazardous Materials, Hydrology and Water Quality, Land Use and Planning, Noise, Public Services, Recreation, Transportation and Traffic, and Utilities and Service Systems. The Final PEIR identifies eight potentially significant impacts related to Air Quality and Greenhouse Gas Emissions which cannot be reduced even with implementation of identified mitigation measures. Because of the large scale of proposed infrastructure improvements for ten Coalition agencies and the uncertainties associated with construction timing, it is not possible to provide a definitive calculation of potential air quality emissions and the emissions estimates that are quantified in the PEIR show that the Project would result in significant emissions of greenhouse gases and regulated air pollutants. Thus, Air Quality and Greenhouse Gas Emissions impacts would be considered significant and unavoidable. Mitigation measures proposed in the Final PEIR will lessen this impact, but cannot completely mitigate adverse environmental impacts to less-than-significant levels.

Under CEQA, approval of the Project will therefore require adoption of Findings of Fact and Statement of Overriding Considerations and an MMRP. The Findings of Fact and Statement of Overriding Considerations reflect the Board's decision to adopt the Proposed Project in light of the significant and unavoidable physical impacts that will result from coordinated Coalition actions. The MMRP provides a commitment to mitigate potential environmental impacts associated with implementation of District project components. Upon approval of their project components, the governing body for each of the Coalition Partners will need to adopt Findings and a Notice of Determination acknowledging reliance on the certified Final PEIR, as well as adopt the MMRP relative to their project components.

FINANCIAL IMPACT

There is no direct fiscal impact associated with the staff report. Implementation of mitigation measures will be required when those individual components are constructed.

No action required. This memorandum is submitted for information only.

Respectfully submitted,



Michael T. Thornton, P.E.
General Manager

SAN ELIJO JOINT POWERS AUTHORITY
MEMORANDUM

November 9, 2015

TO: Board of Directors
San Elijo Joint Powers Authority

FROM: General Manager

SUBJECT: CAPITAL IMPROVEMENT PROJECT – PRELIMINARY TREATMENT UPGRADES

RECOMMENDATION

It is recommended that the Board of Directors:

1. Accept and file the Preliminary Design Report;
2. Approve the Agreement with Dudek for Final Design for an amount not to exceed \$263,522; and
3. Discuss and take action as appropriate.

BACKGROUND

The San Elijo Water Reclamation Facility's preliminary treatment system (also known as "Headworks/Grit" treatment) provides basic physical treatment of the raw wastewater that enters the facility. This treatment system includes mechanical processes that remove trash, rocks, rags, and other debris that can clog, damage, or interfere with downstream treatment. In addition, preliminary treatment removes sand, grit, and other dense materials from the wastewater that can cause premature wearing of pumps and pipes within the treatment plant. The material that is removed is washed, dewatered, and sent to the local landfill for final disposal.

The 2015 Facility Plan recommended Preliminary Treatment system improvements and equipment upgrades to address hydraulic limitations, system wear, and aging equipment. The majority of the equipment and process tanks have more than 24 years of service, and much of the equipment and protective concrete liners (Figure 1) are nearing the end of useful life. The Facility Plan recommended the Preliminary Treatment Upgrades project for construction in 2016.

The SEJPA requested proposals from four engineering firms for the preliminary design phase of this project. Three firms submitted proposals, two of which exhibited a strong comprehension of

the project needs. Staff interviewed the top two teams. The engineering team that provided the best combination of qualifications, project understanding, and value-based approach was submitted by Dudek. At the May 11, 2015 Board meeting a Professional Services Contract was approved for Dudek to prepare a Preliminary Design Report for this project.



Figure 1. Equipment and Concrete Deficiencies

DISCUSSION

The Preliminary Design Report (PDR) provides the basis of design for the project. The PDR examines existing conditions and analyzes hydraulic flow requirements, equipment replacement options, process optimization, concrete channel restoration, and odor reduction while observing operational constraints and constructability issues. The objective of the report is to identify the preferred alternative that best addresses existing deficiencies and provides optimal preliminary treatment at the best value to the community.

Dudek evaluated various options to replace existing equipment and rehabilitate existing structures. The PDR identified five potential construction alternatives that met the project objectives. The proposed alternatives ranged from the construction of a new headworks system and new building (estimated at \$4.64 million) to a combination of new channel structures and equipment combined with the refurbishment of the existing headworks building (estimated at \$2.47 million). The recommended alternative (shown in Figure 2) uses a combination of new channel structures and equipment with the refurbishment of the existing headworks building. Both Dudek and SEJPA Staff recommend this alternative.

At this time, Staff recommends the acceptance of the PDR by the Board.

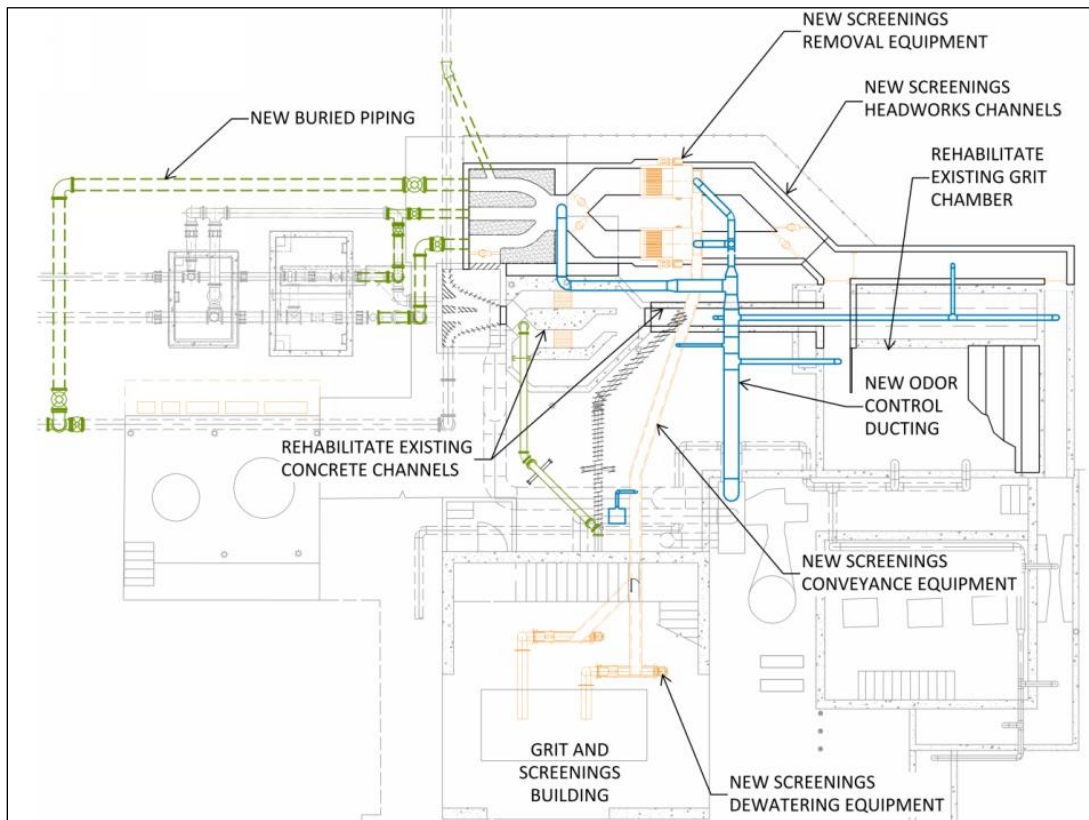

Figure 2. Preferred Alternative

Upon successful completion of the PDR, Staff requested a proposal from Dudek to complete final design. During the final design phase, the preferred alternative will be refined and detailed design drawings and construction specifications will be developed for contractor bidding.

Dudek submitted a proposal to complete the design for \$263,522. Staff obtained a third party (Black & Veatch) review of the scope and fee to ensure the proposal was complete and provided the best value to the agency. Black & Veatch concluded that Dudek's proposal appeared appropriate and cost-effective. Staff recommends award of the Preliminary Treatment Upgrades final design to Dudek for an amount not to exceed \$263,522.

FINANCIAL IMPACT

Acceptance of the Preliminary Design Report has no financial impact.

The award of the Final Design will require a commitment of \$263,522 from the Wastewater Capital Project Fund. Adequate funds are available, with a cash fund balance of \$588,264 designated for the Preliminary Treatment Upgrades project.

The cost estimate included in the PDR is considered an American Association of Cost Engineers (AACE) Class 3 estimate with an expected accuracy of +30% and -20%. Currently the estimated cost of construction is \$2.47 million. In addition to the construction cost, Staff anticipates \$420,000 in costs associated with final design, engineering support during construction, permits, legal, and construction management. These cost estimates will be further refined as the project develops through final design. Funding for the construction portion of this project is planned to be included in a State Revolving Fund (SRF) loan or a municipal bond issuance. This project is on schedule to commence construction in late 2016, with an estimated duration of 12 months.

It is therefore recommended that the Board of Directors:

1. Accept and file the Preliminary Design Report;
2. Approve the Agreement with Dudek for Final Design for an amount not to exceed \$263,522; and
3. Discuss and take action as appropriate.

Respectfully submitted,



Michael T. Thornton, P.E.
General Manager

Attachment 1: San Elijo Water Reclamation Preliminary Treatment Upgrades Preliminary Design Report, Prepared by Dudek, dated November 2, 2015

Attachment 2: Dudek Proposal for the Final Design of SEWRF Headworks Upgrade Project, dated November 2, 2015

FINAL

**San Elijo Water Reclamation Facility
Preliminary Treatment Upgrades
Preliminary Design Report**

Prepared for:

San Elijo Joint Powers Authority

2695 Manchester Avenue

Cardiff by the Sea, CA 92007-7077

Contact: Mike Konicke

Prepared By

DUDEK

605 Third Street

Encinitas, California 92024

Contact: Steve Deering, P.E.

NOVEMBER 2, 2015

SEWRF Preliminary Treatment Upgrades - Preliminary Design Report

THIS PAGE INTENTIONALLY LEFT BLANK

SEWRF Preliminary Treatment Upgrades - Preliminary Design Report

TABLE OF CONTENTS

SECTION	PAGE NO.
EXECUTIVE SUMMARY	I
ES.1 Background and Headworks Description	ES-1
ES.2 Recommended Project.....	ES-1
I INTRODUCTION	I-1
1.1 SEWRF Description	1-1
1.2 Project Background.....	1-1
1.3 Existing Headworks Description	1-2
1.4 Project Objectives.....	1-6
1.5 Report Outline.....	1-7
2 EXISTING AND PROPOSED HYDRAULICS AND LAYOUT	2-1
2.1 SEWRF Flowrates.....	2-1
2.2 Existing Hydraulic Constraints and Channel Layout	2-2
2.3 Proposed Headworks Channel Design.....	2-3
2.3.1 Alleviating Existing Hydraulic Constraints.....	2-4
2.3.2 Screenings Channel Velocities	2-5
2.3.3 Channel Width Analysis	2-5
2.3.4 Emergency Overflow/Bypass Channel	2-6
2.3.5 Alternative Hydraulic Profiles	2-6
2.4 Channel Layout Alternative Analysis	2-8
2.4.1 Temporary or Permanent Bypass During Construction	2-8
2.4.2 Traffic Flow	2-9
2.4.3 Alternative Channel Layout Alternatives	2-9
2.5 Channel Layout Alternative Analysis Recommendations	2-17
3 SCREENING REMOVAL AND HANDLING EQUIPMENT	3-19
3.1 Existing Screening System Description.....	3-19
3.2 Condition Assessment	3-20
3.3 Level of Service Objectives for Screenings Equipment.....	3-21
3.3.1 Equipment Reliability and Redundancy.....	3-21
3.3.2 Screenings Capture Level of Service	3-22
3.4 Alternative Analysis of Screenings Removal Equipment.....	3-24
3.4.1 Equipment Overview	3-24
3.4.2 Analysis Criteria.....	3-25
3.5 Alternative Analysis of Screenings Conveyance Equipment	3-26
3.6 Wash-Press Equipment	3-26
3.7 Screenings Equipment Phasing.....	3-27
3.8 Water Usage.....	3-28
3.9 Recommendations.....	3-28

SEWRF Preliminary Treatment Upgrades - Preliminary Design Report

4	GRIT REMOVAL EQUIPMENT	4-1
4.1	Existing Grit Removal Equipment.....	4-1
4.2	Condition Assessment	4-2
4.3	Grit Removal Evaluation	4-2
4.4	Grit Aeration Blowers Elimination Analysis.....	4-3
4.5	Recommendations.....	4-4
5	STRUCTURAL	5-5
5.1	Existing Structural and Coating Materials.....	5-5
5.2	Condition Assessment	5-5
5.3	Structural Rehabilitation	5-6
5.4	Structural Modifications.....	5-6
5.5	Channel and Grit Chamber Covers.....	5-7
5.6	Structural Recommendations	5-7
6	ODOR CONTROL SYSTEMS	6-9
6.1	Existing Odor Control Equipment	6-9
6.2	Condition Assessment	6-10
6.3	Equipment Relocation.....	6-11
6.4	Odor Control During Construction.....	6-11
6.5	Existing Odor Control System Flowrates.....	6-11
6.6	Odor Scrubber Loading Evaluation	6-12
6.7	Odor Control Optimization	6-12
6.8	Recommendations.....	6-13
7	ELECTRICAL	7-15
7.1	General	7-15
7.2	Power Distribution	7-15
7.3	Odor Control Panel (LCP-ORH)	7-15
7.4	SCADA	7-16
7.5	NFPA 820.....	7-16
7.6	Equipment Panels.....	7-16
7.7	Existing Flow Meter Vaults.....	7-16
7.8	Lighting.....	7-17
7.9	Recommendations.....	7-17
8	PROJECT IMPLEMENTATION	8-1
8.1	Recommended Project.....	8-1
8.2	OPCC	8-5
8.3	Project Implementation Schedule.....	8-5
8.4	Permitting Requirements	8-5
	8.4.1 CEQA Permitting.....	8-5
	8.4.2 Stormwater Permitting.....	8-6

SEWRF Preliminary Treatment Upgrades - Preliminary Design Report

LIST OF FIGURES

Figure ES-1: Recommended Project Plan	ES--2
Figure 1-1: Headworks Location	1-1
Figure 1-2: Existing Headworks Site Plan	1-3
Figure 2-1: Existing Hydraulic Constraints.....	2-3
Figure 2-2: Overflow/Bypass Channel Cross Section.....	2-6
Figure 2-3: Hydraulic Profile at PDWF (2-foot wide channel)	2-7
Figure 2-4: Hydraulic Profile at PDWF (3-foot wide channel)	2-8
Figure 2-5: Layout Alternatives 1 and 2.....	2-11
Figure 2-6: Layout Alternatives 3 and 4.....	2-13
Figure 2-7: Layout Alternative 5.....	2-15
Figure 3-1: Relative Performance of Mechanically Cleaned Screen Types	3-23
Figure 3-2: Screenings Equipment Phasing Plan.....	3-28
Figure 4-1: Grit Piping Alignment.....	4-3
Figure 5-1: Un-Punched Aluminum Plank Grating.....	5-7
Figure 7-1: Conduit Rack.....	7-15
Figure 8-1: Preliminary Mechanical Plan	8-3
Figure 8-2: Preliminary Mechanical Sections.....	8-5
Figure 8-3: Recommended Process Flow Diagram	8-1
Figure 8-4: Recommended Hydraulic Profile.....	8-3

LIST OF TABLES

Table 1-1: Headworks Components	1-5
Table 1-2: Significant Projects for SEWRF Headworks.....	1-6
Table 2-1: SEWRF Flowrate Criteria	2-2
Table 2-2: Channel Layout Alternative Comparison.....	2-15
Table 3-1: Existing Screening Equipment.....	3-20
Table 3-2: Reliability / Redundancy Measures for Screenings Equipment.....	3-22
Table 3-3: Screen Selection Analysis Criteria	3-25
Table 3-4: Screen Evaluation Matrix.....	3-25
Table 3-5: Screenings Conveyance Equipment Comparison	3-26
Table 4-1: Existing Grit Removal Equipment.....	4-1
Table 4-2: Grit Chamber Design Criteria.....	4-3
Table 6-1: Existing Odor Control Equipment.....	6-10
Table 6-2: Existing Odor Control Air Flowrates and Ventilation Rates	6-11
Table 6-3: Odor Scrubber Design Criteria.....	6-12
Table 8-1: Anticipated Project Schedule	8-5

SEWRF Preliminary Treatment Upgrades - Preliminary Design Report

APPENDICES

- A Site Observation Photos
- B Kickoff Meeting Presentation
- C Screenings Equipment Vendor Brochures
- D Engineer's Opinion of Probable Construction Cost

SEWRF Preliminary Treatment Upgrades - Preliminary Design Report

ABBREVIATIONS

ADF	Average Daily Flow
ADWF	Average Dry Weather Flow
AFY	Acre-Feet per Year
BMP	Best Management Practice
CEQA	California Environmental Quality Act
cfs	cubic feet per second
EGL	Energy Grade Line
ESA	Environmentally Sensitive Area
Facility	San Elijo Water Reclamation Facility
FRP	Fiberglass Reinforced Plastic
gpm	gallons per minute
gpd	Gallons per day
H ₂ S	Hydrogen Sulfide gas
HGL	Hydraulic Grade Line
HP	Horsepower
HWL	High Water Level
I/O	Input/Output
IE	Invert Elevation
IJC	Influent Junction Chamber
LCP	Local Control Panel
MCC	Motor Control Center
MGD	million gallons per day
NFPA	National Fire Protection Association
O&M	Operation and Maintenance
OPCC	Opinion of Probable Construction Cost
PDR	Preliminary Design Report
PDWF	Peak Dry Weather Flow
PLC	Programmable Logic Controller
ppm	parts per million
PVC	Polyvinyl Chloride
PWWF	Peak Wet Weather Flow
SCADA	Supervisory Control And Data Acquisition
SEJPA	San Elijo Joint Powers Authority
SEWRF	San Elijo Water Reclamation Facility
sqft	square feet

SEWRF Preliminary Treatment Upgrades - Preliminary Design Report

SWPPP	Stormwater Pollution Prevention Plan
TOC	Top Of Concrete
UV	Ultraviolet Radiation
WL	Water Level
WQMP	Water Quality Management Plan
y_c	Critical depth
y_n	Normal depth

SEWRF Preliminary Treatment Upgrades - Preliminary Design Report

EXECUTIVE SUMMARY

ES.1 Background and Headworks Description

The San Elijo Joint Powers Authority (SEJPA) owns and operates the San Elijo Water Reclamation Facility (SEWRF) which is located in Cardiff-by-the-Sea, California. The SEWRF, with a permitted capacity of 5.25 million gallons per day (MGD), receives approximately 3 MGD of wastewater from the cities/communities of Encinitas, Solana Beach, a portion of Rancho Santa Fe and in the future a portion of Del Mar. The treatment train consists of headworks (bar screens and grit removal) followed by primary sedimentation, primary effluent equalization, conventional non-nitrifying activated sludge secondary treatment, and tertiary treatment processes. Secondary treated wastewater is either recycled or discharged to the San Elijo Ocean Outfall.

The Headworks is responsible for the preliminary treatment at the SEWRF by removing solids and debris from the wastewater stream to protect downstream processes and equipment. The SEWRF Headworks consists of screening, grit removal, and odor control systems. A number of Headworks issues have been identified with regard to the equipment condition and reliability, hydraulic capacity, concrete deterioration, and odor control. The headworks has been modified since its original construction in 1964 (projects in 1981, 1989, and 2003) including reconfiguring channel layouts (1981), adding new screens and grit equipment (1989), and installing a screening wash-press (2003).

ES.2 Recommended Project

The objective of the SEWRF Headworks Rehabilitation and Upgrade project is to implement upgrades to the headworks that will relieve hydraulic constraints; increase screenings capture efficiency, and improve redundancy and reliability while observing operational constraints and constructability issues and improve odor control. A Preliminary Design Report (PDR) has been prepared to clearly identify improvements and budgetary costs for the Headworks Rehabilitation and Upgrade project. The PDR recommendations are as follows:

- Construct new Headworks screenings channels with higher hydraulic capacity just north of existing Headworks. The existing Headworks channels will remain in operation while new facility is constructed.
- Rehabilitate existing concrete Headworks screenings channels and Grit Chamber after new channels are in service. Existing concrete channels will be reused for overflow and bypass purposes.
- Install new screenings removal, conveyance, and dewatering equipment to reduce trash and debris loading on downstream processes and equipment
- Optimize existing odor control system by containing foul air with improved covers of equipment and channels, and by adding new and rebalancing foul air ducting flow rates

SEWRF Preliminary Treatment Upgrades - Preliminary Design Report

Overall the Headworks Rehabilitation and Upgrade project would implement upgrades to previous modifications, which would result in an enhanced performance of SEWRF. See Figure ES-1 for plan of the recommended project.

The total construction cost is anticipated to be \$2,470,000. Construction is expected to begin in January 2017, and be completed in January 2018.

Figure ES-1: Recommended Project Plan

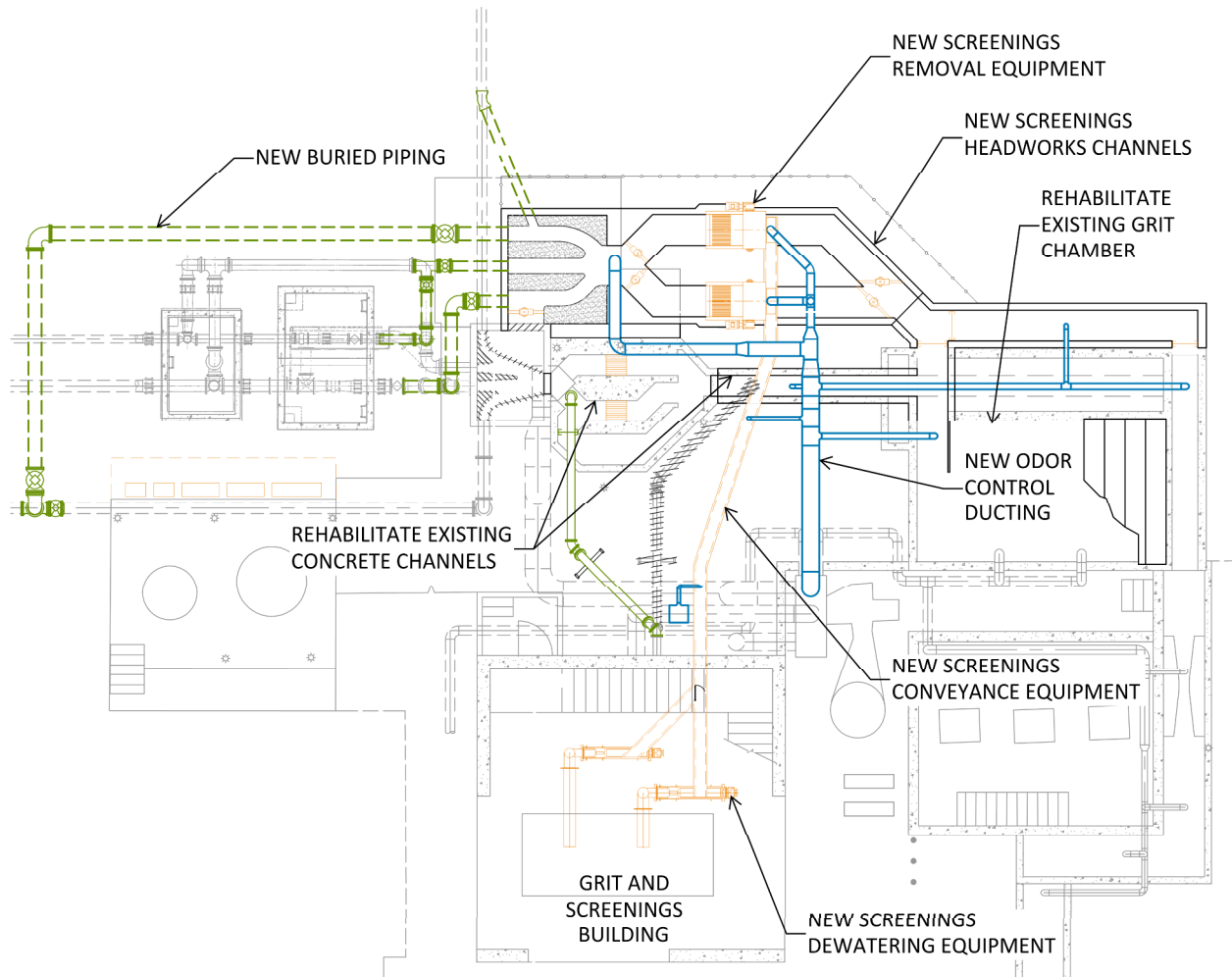

SEWRF Preliminary Treatment Upgrades - Preliminary Design Report

I INTRODUCTION

I.1 SEWRF Description

The San Elijo Joint Powers Authority (SEJPA) owns and operates the San Elijo Water Reclamation Facility (SEWRF or Facility) which is located in Cardiff-by-the-Sea, California. The SEWRF, with a permitted capacity of 5.25 million gallons per day (MGD), receives slightly less than 3 MGD of wastewater from the cities/communities of Encinitas, Solana Beach, and a portion of Rancho Santa Fe. The treatment train consists of bar screens and grit removal followed by primary sedimentation, primary effluent equalization, conventional non-nitrifying activated sludge secondary treatment, and tertiary treatment processes. Secondary treated wastewater is either recycled or discharged to the San Elijo Ocean Outfall. The SEWRF produces approximately 1,300 acre-feet per year (AFY) of Title 22 Recycled Water from its 3 MGD tertiary treatment facility, which includes flocculation, continuous backwash sand filters (2.5 MGD), a sodium hypochlorite and contact tank disinfection system; and a side-stream microfiltration/reverse osmosis train (0.5 MGD). Recycled water is sold to the San Dieguito Water District, Santa Fe Irrigation District, City of Del Mar, Caltrans, and the Olivenhain Municipal Water District.

I.2 Project Background

The Headworks is located towards the north end of the plant as shown in Figure I-1. The Headworks is responsible for the preliminary treatment at the SEWRF by removing solids and debris from the wastewater stream to protect downstream processes and equipment. The SEWRF Headworks consists of screening, grit removal, and odor control systems. A number of Headworks issues have been identified with regard to the equipment, hydraulic capacity, concrete deterioration, and odor control. The **SEWRF Headworks Upgrade Project** will rehabilitate the Headworks to remedy identified needs.

Figure I-1: Headworks Location

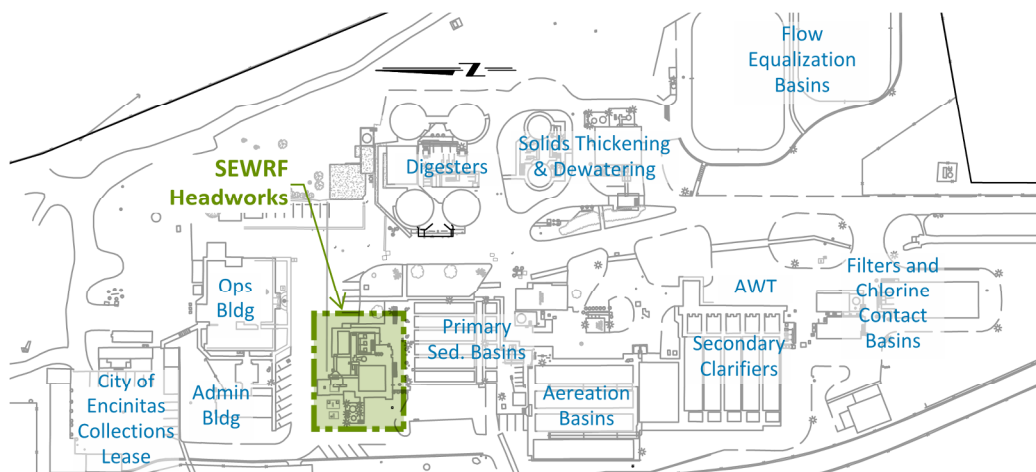

SEWRF Preliminary Treatment Upgrades - Preliminary Design Report

I.3 Existing Headworks Description

Three (3) separate sewer forcemains (Solana Beach, Cardiff, and Olivenhain) and the Cardiff sewer gravity main (backdoor pipeline) flow into a concrete influent junction chamber. Combined flow from the forcemains and gravity sewer bifurcate into two (2) separate concrete open channels, each channel having mechanically cleaned bar screens installed. These mechanical bar screens automatically rake captured screenings from their bar racks and discharge the screenings into a single wash press. Screenings are then washed and compacted before being discharged into a bin stored outdoors. Under emergency high flow conditions, wastewater diverts to an overflow weir/slide gate and passes through a manually cleaned bar rack installed in the bypass/overflow channel.

Screened wastewater flows from the bar screens, through concrete open channels, and into an aerated grit chamber. Two (2) aeration blowers installed in bottom floor of the Grit and Screenings Building supply air to the grit chamber diffusers. Grit which settles in the aerated grit chamber hoppers is pumped out by three (3) grit pumps up to the two (2) grit classifiers installed on the top floor of the Grit and Screenings Building. The classifiers separate water and organics from the grit and discharge the grit into a dumpster on the first floor of the building. The outdoor screenings bin is periodically emptied into the dumpster.

Wastewater spills over the grit chamber effluent weir, through a Parshall flume, and then to the primary sedimentation tank channels. The headspace Grit and Screenings Building, Influent Junction Chamber, Grit Chamber, and a few of the grit effluent channels are ventilated by a centrifugal fan to the Headworks Chemical Odor Scrubber.

The existing headworks site plan is shown in Figure I-2.

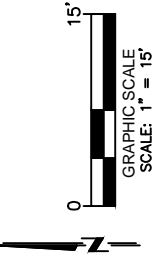
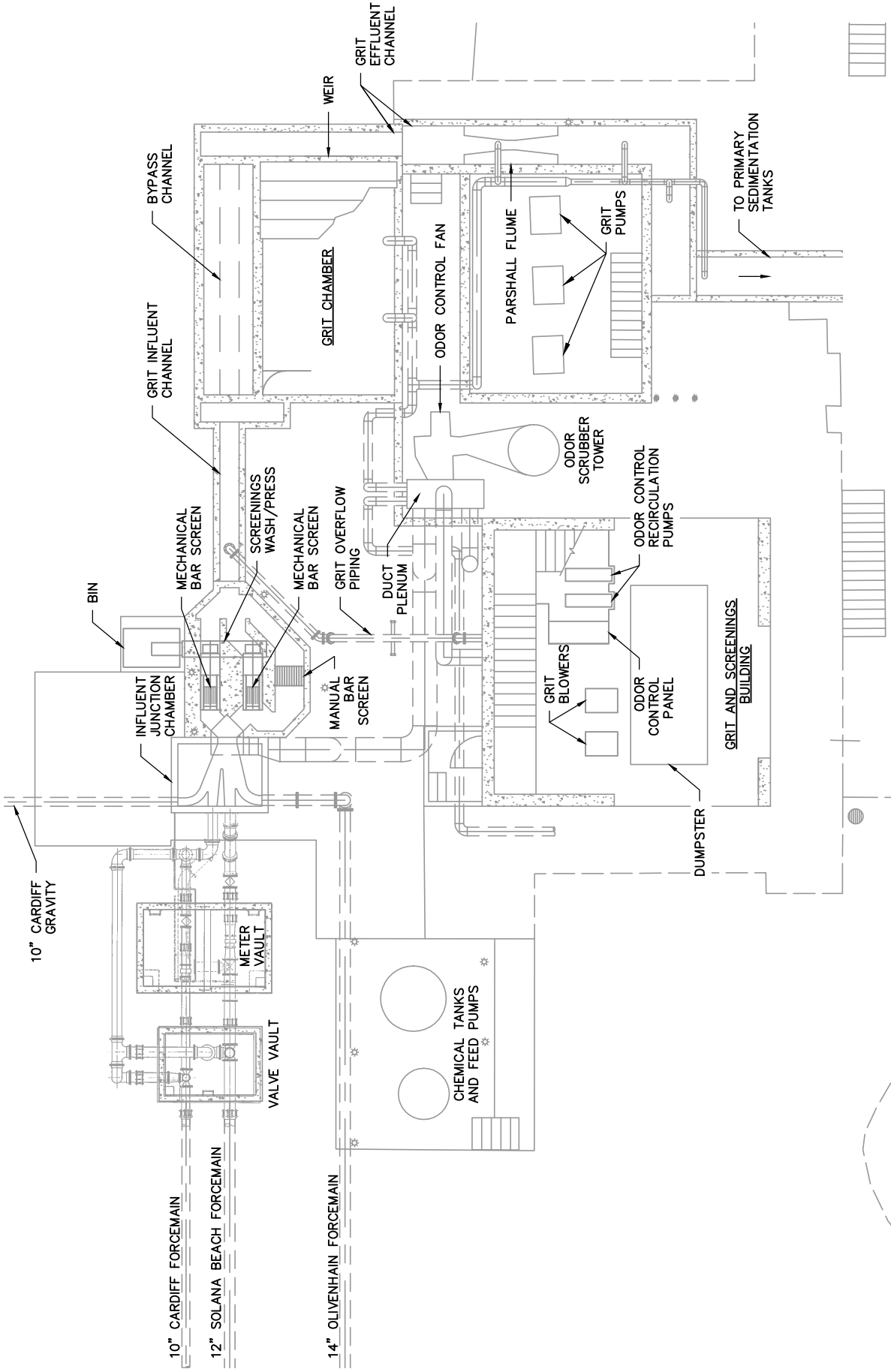

FIGURE 1-2
EXISTING HEADWORKS
SITE PLAN

SEWRF Preliminary Treatment Upgrades - Preliminary Design Report

THIS PAGE INTENTIONALLY LEFT BLANK

SEWRF Preliminary Treatment Upgrades - Preliminary Design Report

The screenings, grit removal, and odor control components of the SEWRF Headworks are listed in Table I-1 with notation as to quantity, duty/standby status, and age of installation.

Table I-1: Headworks Components

System/Component	Quantity	# Duty / # Standby	Year Installed	Comments
Screenings Removal System				
Mechanically cleaned (reciprocating rake) bar screens	2	2 / 0	1989	
Manually cleaned bar rack	1	1 / 0	1981	For overflow/ bypass
Wash/press	1	1 / 0	2003	
Grit Removal System				
Aerated grit chamber	1	1 / 0	1964	
Grit blowers (Positive displacement)	2	1 / 1	1989	
Grit pumps	3	2 / 1	1989	
Grit classifiers/cyclones	2	1 / 1	2003	
Odor Control System				
Chemical scrubber tower	1	1 / 0	1989	
Recirculation pumps	2	1 / 1	1989	
Sodium hypochlorite Tank	1	1 / 0	1989	Not in use
Sodium hypochlorite feed pumps	2	1 / 1	1989	Not in use
Caustic soda Tank	1	1 / 0	1989	
Caustic soda feed pumps	2	1 / 1	1989	
Water softening package units	2	1 / 1	1989	Not in use

The names, dates, project elements, and design flow for a number of projects related to the SEWRF Headworks are summarized in Table I-2. Although the peak design flow for the 1989 Headworks project was noted in the original construction documents as 13.6 MGD, SEJPA Staff indicate that channel and/or influent junction chamber overflow is likely at flow greater than approximately 8.2 MGD.

SEWRF Preliminary Treatment Upgrades - Preliminary Design Report

Table I-2: Significant Projects for SEWRF Headworks

Project/Designer/Date	Elements Relevant to Current Project	Design Flow Average / Peak MGD
Cardiff/Solana Beach Sanitation District San Elijo Water Pollution Control Facility (County of San Diego, 1964)	<ul style="list-style-type: none"> Original plant construction Constructed influent junction chamber, comminution/bar rack structure, grit chamber, and primary sedimentation tanks Installed grit chamber blowers, air-lift grit pumps, and grit classifier 	2.0 / 4.5
Cardiff Sanitation District San Elijo WPCF Enlargement and Upgrading (Brown & Caldwell, 1981)	<ul style="list-style-type: none"> Raised height of existing comminution/bar rack structure channels by 12 inches Added 3rd channel and a 2nd comminutor 	3.0 / 6.41
San Elijo Joint Powers Authority San Elijo Water Pollution Control Facility (Malcom Pirnie, 1989)	<ul style="list-style-type: none"> Constructed Screenings/Grit Building, grit pump pit, Parshall flume, primary sedimentation tanks 4 through 6. Replaced existing two comminutors with reciprocating bar screens and replaced existing grit aeration blowers. Installed screenings belt-conveyor, odor control tower, odor control recirculation/chemical pumps, equipment, grit classifier, and grit pumps Extended downstream screen channels to accommodate installation of screenings conveyor 	5.25 / 13.6
San Elijo Joint Powers Authority Headworks Facility Modifications (PBS&J, 2003)	<ul style="list-style-type: none"> Removed existing screenings conveyor Installed screenings wash/press Installed 2nd grit classifier 	No Capacity Increase From Prior
San Elijo Joint Powers Authority San Elijo Water Reclamation Facility Electrical Upgrades Project (CDM, 2011)	<ul style="list-style-type: none"> Installed new motor control center (MCC) building Installed electrical conduit from headworks equipment to new MCC building 	N/A

I.4 Project Objectives

The objectives of the current SEWRF Headworks Upgrade Project are as follows:

- Relieve hydraulic constraints
- Increase equipment, hydraulic, and structure reliability and redundancy
- Optimize screenings removal efficiency
- Improve Headworks access and optimize O&M for handling of screenings
- Maintain plant operations, accessibility, and constructability of project
- Improve odor control of Headworks area

SEWRF Preliminary Treatment Upgrades - Preliminary Design Report

I.5 Report Outline

To meet the project objectives listed above, this Preliminary Design Report (PDR) will review existing conditions, analyze design criteria, perform alternative analysis, and recommend improvements for the following aspects of the SEWRF Headworks Upgrade Project:

- Section 1: Introduction
- Section 2: Hydraulics and Layout
- Section 3: Screenings Systems
- Section 4: Grit Systems
- Section 5: Structural Elements
- Section 6: Odor Control Systems
- Section 7: Electrical and Instrumentation
- Section 8: Project description, cost, schedule, and permitting requirements

SEWRF Preliminary Treatment Upgrades - Preliminary Design Report

THIS PAGE INTENTIONALLY LEFT BLANK

SEWRF Preliminary Treatment Upgrades - Preliminary Design Report

2 EXISTING AND PROPOSED HYDRAULICS AND LAYOUT

2.1 SEWRF Flowrates

The SEWRF is permitted capacity of 5.25 MGD. Currently, the SEJPA measures influent flowrate at the Parshall flume downstream of the grit chamber. Based on an analysis of flow data provided by SEJPA, the SEWRF receives an average dry weather flow (ADWF) rate of 2.64 MGD with a diurnal peak dry weather factor of 1.93. Recently, an agreement with the City of Del Mar has been finalized to accept an additional 0.50 MGD ADWF (through Solana Beach forcemain) which will bring the average daily flow to about 3.14 MGD. A goal of the SEJPA, separate from the Headworks Project, is to increase the average daily flow to the SEWRF through additional agreements with Del Mar and others to take advantage of the existing excess plant capacity and maximize recycled water use. This separate goal is also consistent with the proposed hydraulic design capacity of the screenings and grit removal facilities.

The SEWRF reportedly received an hourly peak wet weather flow (PWWF) rate during a rain event in July 2005 of 8.2 MGD. As shown in Table 1-2, when the existing bar screens were installed, the Headworks was designed for a peak wet weather flow rate of 13.6 MGD. However, SEJPA indicates that flowrate of 8.2 MGD results in minimal channel freeboard and any additional flow will likely cause wastewater to overflow the channels and/or influent junction chamber. It is the goal of the current project to restore a peak Headworks hydraulic design capacity of 13.6 MGD, as intended in the 1989 SEWRF Improvements Project. This will accommodate dry and wet weather peak flows above 8.2 MGD to the bypass design limit of 13.6 MGD.

At the SEWRF ADF capacity of 5.25 MGD, the design diurnal PDWF is estimated at $5.25 \times 1.93 = 10.15$ MGD. The design of the current project will provide screenings of all dry weather flow with any excess flow above the PDWF (10.15 MGD) overflowing a weir and passing through a manually cleaned bar rack. This tactic will optimize both sizing of mechanical screens for solids removal as well as the hydraulic velocity in the channels needed to minimize solids deposition. Furthermore, the estimated design PDWF of 10.15 MGD is approximately equal to the sum of the planned peak capacity of the three influent pump stations and backdoor pipeline gravity sewer.

The flowrate design criteria for the SEWRF Headworks Upgrade Project are summarized in Table 2-1.

SEWRF Preliminary Treatment Upgrades - Preliminary Design Report

Table 2-1: SEWRF Flowrate Criteria

Flow Criteria	Unit	Existing SEWRF Flow	Existing plus Del Mar	Design Flow (SEWRF Capacity)
Average Dry Weather Flow (ADWF)	MGD	2.64	3.14	5.25
Peak Dry Weather Flow (PDWF) - Peak Factor	-	1.93	1.93	1.93
Peak dry weather flow (PDWF)	MGD	5.11	6.07	10.15
Peak Hydraulic Capacity	MGD	8.2	N/A ¹	13.6

2.2 Existing Hydraulic Constraints and Channel Layout

Wastewater flows into the Influent Junction Chamber from the three (3) sewer forcemains and single gravity sewer main. This combined flow bifurcates into two (2) separate concrete open channels, each with mechanically cleaned bar screens installed. Under emergency high flow conditions, wastewater diverts to an overflow weir/slide gate and passes through a manually cleaned bar rack installed in the bypass/overflow channel. Screened wastewater re-combines and flows through concrete open channels, and into an aerated grit chamber. Wastewater spills over the grit chamber effluent weir, through a Parshall flume, and then to the primary sedimentation tank channels.

The existing headworks channels are about 2-feet wide with 6-inch fillets in the bottom corners of the channels. The Influent Junction Chamber, screenings and grit channels, and grit chamber were all constructed in approximately 1964, when the flows were approximate 2.0 MGD ADWF and 4.5 MGD PDWF. Modifications to the channels since the original construction included adding a 3rd channel for overflow/bypass, and raising the screening channels and Influent Junction Chamber, not including the grit influent/outlet channels, by 12 inches, and adding a 12-inch wide (throat) Parshall flume.

As discussed earlier, the existing Headworks is not able to convey the peak hydraulic design flow of 13.6 MGD. Several features of the existing Headworks which control hydraulic grade line and/or create excessive headloss include:

- Inlet confluence and turbulence of three forcemains and one sewer
- Two screens in service is required to avoid excessive screen headloss
- Two locations of enclosed channel with low soffits that create orifice headloss
- The channel outlet into the Grit Chamber hydraulically causes flow to pass through critical depth, which has a hydraulic grade line (HGL) control effect similar to a weir

¹ Note that SEWRF will have the option to remotely divert Del Mar flow to San Diego during periods of high wet weather flow

SEWRF Preliminary Treatment Upgrades - Preliminary Design Report

- Wastewater passes through three (3) abrupt 90-degree bends just upstream of the grit chamber
- The headloss due to the 12-inch Parshall flume following the grit chamber is high enough at high flows to submerge the Grit Chamber effluent weir. However, this submergence is not high enough to inundate the Grit Chamber inlet water levels

High velocities exceeding 6 fps would occur near the Grit Chamber inlet at design peak flows. As headloss builds up through the abrupt 90-degree bends, the water depth increases and the velocities slow to less than 4 fps. Current operations include two (2) screens in service at all times which reduces the screen channel flow rate and velocities in half when compared to all flow through one screen.

Upstream of the screens, channel velocities further reduce to less than 1 fps at average daily flows. Despite these low approach velocities, solids deposition has not been reported to be a problem in the upstream headworks channels.

The hydraulic constraints are graphically shown in Figure 2-1.

Figure 2-1: Existing Hydraulic Constraints

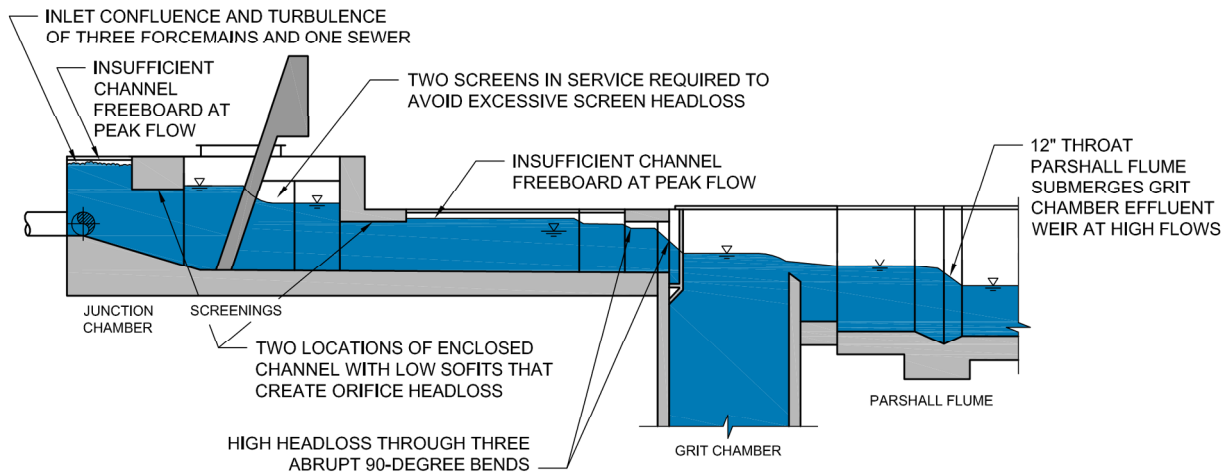

2.3 Proposed Headworks Channel Design

There are several hydraulic design criteria items to consider for the Headworks Upgrade Project before reviewing mechanical screen alternatives in detail. These criteria include:

- New mechanical screens are required with a PDWF capacity of 10.15 MGD as discussed in Section 2.1.

SEWRF Preliminary Treatment Upgrades - Preliminary Design Report

- To avoid pumped bypass during construction and to insure reliability and redundancy, the construction work will need to be completed in two hydraulically parallel phases each with a coordinated level of mechanical and manually cleaned standby capacity
- Mechanical screen bar spacing should be ¼-inch, as discussed later herein regardless of specific mechanical cleaning type or manufacture. Therefore, the hydraulic losses for all mechanical screen alternatives are approximately equal. The number and width of channels and mechanically cleaned bar screens can therefore be analyzed regardless of the special mechanical screens ultimately installed
- The size and depth of channels upstream and downstream of the proposed screens should be based on the acceptable range of channel velocity to avoid grit settlement on during low flow/velocity and to avoid screenings push-through during high flow/velocity. There are various combinations of number of channels, channel width(s), and channel depths within the range of acceptable criteria that could provide a workable basis of design
- Manually cleaned bar rack channel(s) with a 13.6 MGD hydraulic capacity and at least one gated channel with no mechanical screen or rack should be provided for all alternative layout evaluations.
- The existing Headworks channels and any proposed new parallel or replacement channels must have top of wall high enough to provide 1-foot of freeboard under peak dry weather and peak wet weather hydraulic flow conditions
- The existing channels are 2-feet wide and are close to overtopping at 8.2 MGD. However, if the hydraulic constraints are removed, the existing channels can convey the 13.6 MGD.
- New channels could be of any width meeting the velocity criteria under the various alternative schemes if the hydraulic constraints are removed.
- The existing Headworks channels could be reused for mounting either: 1) new screenings equipment, or 2) for re-purposing as manually cleaned bar rack by-pass channel(s)

2.3.1 Alleviating Existing Hydraulic Constraints

If the existing channels are to continue in use (whether for installing new screens or overflow/bypass), the existing hydraulic constraints identified above should be removed to lower the hydraulic profile of the existing Headworks channels. Improvements to alleviate the constraints of the existing channels would consist of the following:

- Saw-cutting and revising the concrete channels to remove the two sections with low soffits
- Widen the Grit Chamber inlet channels to reduce velocity and/or modify the channels to use not more than one (1) 90-degree channel bend
- Raise channel heights to maintain minimum freeboard of approximately 1-foot above the overflow weir nappe height at PWWF.

SEWRF Preliminary Treatment Upgrades - Preliminary Design Report

Any new Headworks channels should have the following characteristics:

- Meet the velocity criteria to avoid grit settlement and screenings push-through
- Recess bar screen side frames into channel walls to increase screen area and decrease headloss
- Minimize use of channel bends
- Use 45-degree channel bends where possible.

2.3.2 Screenings Channel Velocities

To minimize solids deposition during low flows, channels dimensions should be sized to the greatest degree possible to maintain velocities above 1.3 fps in accordance with typical industry practice. If velocities below 1.3 fps cannot be avoided, the channels should be designed to the greatest degree possible to exceed velocities of 2.5 fps for typical daily peaks to re-suspend any settled solids.² Note, however, that the SEWRF Headworks currently experiences velocities less than recommended and does not appear to experience significant problems with solids deposition.

When high velocities through the bar screen openings occur, screenings trapped on the bar screen can be pushed through. To minimize screenings “push-through,” through-screen velocities for typical daily peaks should be limited to approximately 5 fps.³ Hydraulic calculations included herein are based on 1/4-inch bar screen spacing, as later discussed and recommended herein.

2.3.3 Channel Width Analysis

If the existing hydraulic constraints are removed in the existing 2-foot wide channels, the two existing 2-foot wide channels could be retrofitted with duty screens of various competing manufacture without excessive headloss at a combined two-screen capacity of 10.15 MGD PDWF. A third similar size screen in a new 3-foot wide channel would be required for standby, if this screen sizing approach were used. Additional freeboard would need to be added to the existing Influent Junction Chamber, screenings channels, and Grit Chamber inlet channel.

Optimum velocities and depths may also be achieved using a 3-foot wide channel with one (1) duty screen sized for 10.15 MGD PDWF. A second similar size screen would be required for standby, if this screen sizing approach were used. For 3-foot wide channels, fillets would be added to the bottom corners of the channels to reduce solids deposition potential.

If the existing hydraulic constraints are removed in the existing 2-foot wide channels, the two existing 2-foot wide channels could be retrofitted with manually cleaned bar racks and then be

² *Wastewater Engineering: Treatment and Resource Recovery, Metcalf & Eddy / AECOM, 5th ed.,*

³ *Conversation with Norm Jackman, Vulcan Industries, 8/28/2015*

SEWRF Preliminary Treatment Upgrades - Preliminary Design Report

used as a combined bypass with a capacity exceeding 13.6 MGD. Additional freeboard would need to be added to the Grit Chamber inlet channel.

2.3.4 Emergency Overflow/Bypass Channel

The design of the current project will provide screenings of all dry weather flow. Any excess flow above the estimated 10.15 MGD PDWF will spill over an overflow weir which would then flow around the mechanically cleaned screens through a manually cleaned bar rack. This tactic will allow the new screen(s) to operate in a more optimal range of channel and face velocity without having to raise the channel walls excessively. As shown in Figure 2-2, the overflow weir governs the height of the channels. For this alternative approach, approximately one (1)-foot of freeboard would be provided above the nappe height for the full 13.6 MGD PWWF flowing over the weir.

Figure 2-2: Overflow/Bypass Channel Cross Section

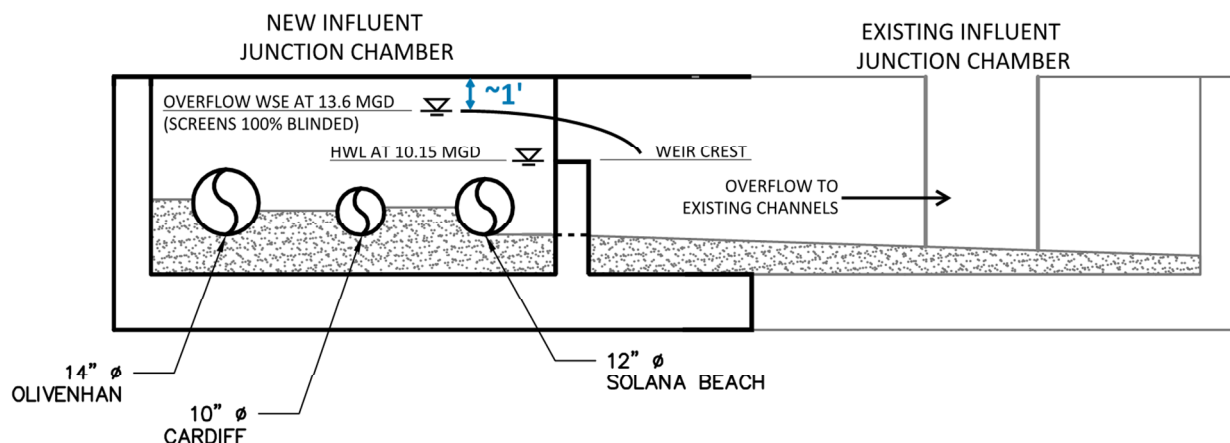

2.3.5 Alternative Hydraulic Profiles

A total of five (5) Headworks channel layout alternatives are being considered and are further described later in this Section. Of those, the hydraulic profiles (from the Grit Chamber Inlet through new mechanically cleaned screens to the Influent Junction Box) for Channel Layout Alternative 1 and Alternative 2 are discussed and shown below. The hydraulic profiles through the bypass manually cleaned bar racks and empty gated channel for each alternative layout are less critical hydraulically and are therefore not shown in detail here.

For Channel Layout Alternative 1, the hydraulic profile from the Grit Chamber inlet (Channel Length "0") to the Influent Junction Chamber (Channel Length "55") for two parallel duty 2-foot wide channels fitted with 5.075 MGD mechanical screens is shown in Figure 2-3. The two duty screens in parallel would provide a total capacity of 10.15 MGD. A third screen with a capacity of 10.15 MGD in a new 3-foot wide channel would also be required, but the hydraulic profile

SEWRF Preliminary Treatment Upgrades - Preliminary Design Report

would be lower, and would not affect the normal hydraulic profile. The following hydraulic profile matches the site plan Layout Alternative 1, as described later in this report.

Figure 2-3: Hydraulic Profile at PDWF (2-foot wide channel)

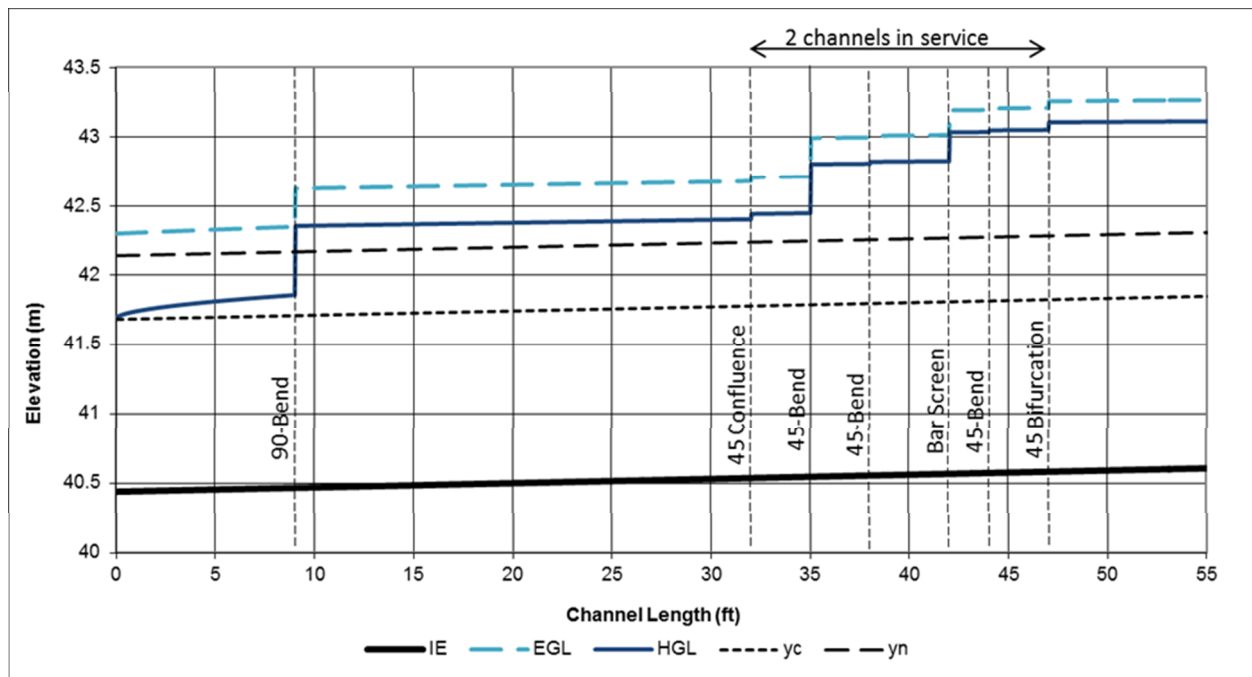

For Channel Layout Alternative 2, the hydraulic profile from the Grit Chamber inlet (Channel Length “0”) to the Influent Junction Chamber (Station “60”) for a single 3-foot wide channel fitted with a 10.15 MGD mechanical screen is shown in Figure 2-4. A second 10.15 MGD standby screen in another new 3-feet wide channel would also be required, but would not affect the hydraulic profile. This hydraulic profile matches the site plan for Layout Alternative 2, as described later in this report.

SEWRF Preliminary Treatment Upgrades - Preliminary Design Report

Figure 2-4: Hydraulic Profile at PDWF (3-foot wide channel)

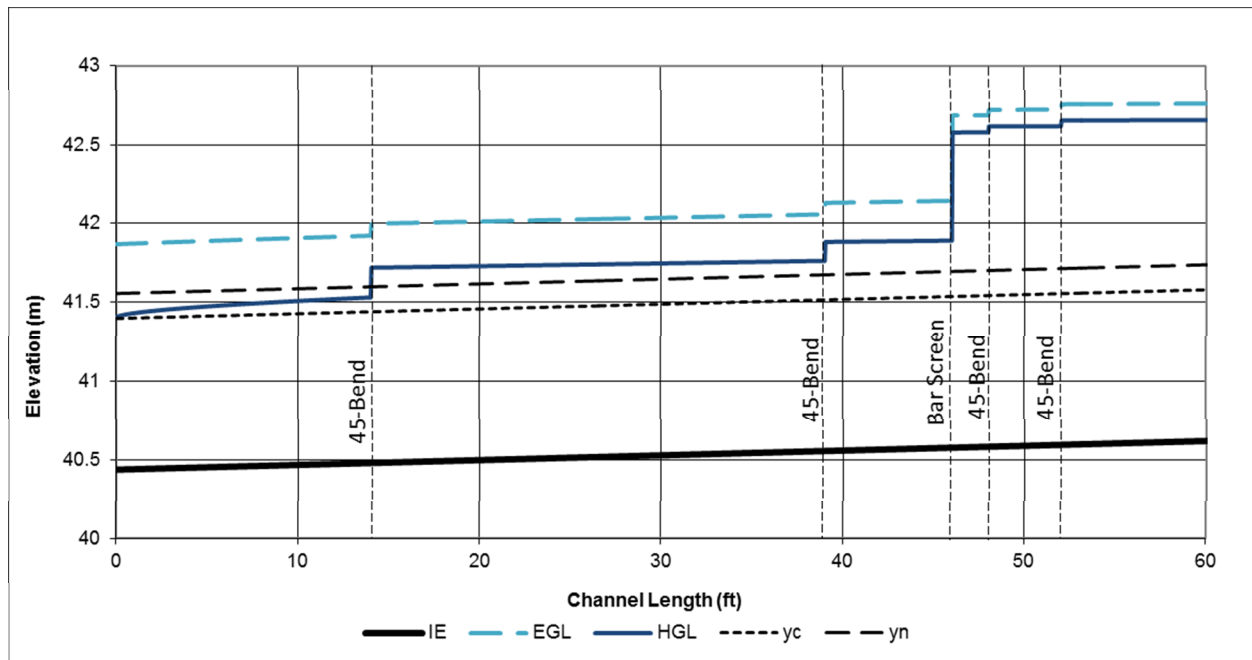

As can be seen in the above graphics, the Channel Layout Alternative 1 using the existing 2-foot wide channels for two parallel duty screens is slightly shorter in length and results in a Hydraulic Grade Line (HGL) nearly 1-foot higher than the Channel Layout Alternative 2 using new 3-foot wide channel for a single duty screen.

Any rise in the Influent Junction Chamber HGL will slightly reduce the capacity of the three influent pump stations, as the static head pressure for the upstream pumps will go up the same amount. This will also cause the gravity flow Cardiff Backdoor Pipeline HGL to rise above top of pipe requiring this gravity pipeline to run under a very minor positive pressure for a short distance upstream from the Headworks connection.

2.4 Channel Layout Alternative Analysis

2.4.1 Temporary or Permanent Bypass During Construction

Construction modification of the existing channels to alleviate hydraulic constraints will require wastewater to be bypassed around the channels during the work. Un-screened wastewater should not be permitted to bypass around the headworks during this period. Potential options for bypassing would include temporary or permanent screening as follows:

- Intercept and connect to the existing forcemains before they reach the influent junction box and install temporary highline piping with a temporary manual bar rack screen and integral overflow/bypass channel. Installing temporary screens would require the collected screenings to be raked multiple times per day, which will increase construction

SEWRF Preliminary Treatment Upgrades - Preliminary Design Report

costs and increase likelihood of foul odor release. Defining and enforcing construction responsibilities for the temporary screenings facility will add complexity, risk of inadequate maintenance by the contractor during construction, and general difficulty to the project, and thus a higher potential for change orders, conflicts, and variability in construction costs are anticipated. Layout alternative 4 incorporates this bypass method.

- Construct new permanent screen channel(s) around the existing facility for use during modification of the existing channels and for permanent use following construction. Constructing new permanent screen channels would provide a better use of funds and reduce temporary systems. Layout alternatives 1, 2, 3, and 5 incorporate this bypass method.

Considering the two above options, it is recommended that a new permanent screen channel be constructed around the existing facility.

2.4.2 Traffic Flow

All layout alternatives will maintain a minimum of 30-feet between the existing parking stalls and the new headworks channels to ensure sufficient access for the Encinitas sewer maintenance vehicles and other related local traffic driving through this area. This cannot be accomplished without first removing or replacing the existing screenings wash-press equipment. To facilitate this construction approach, the proposed new wash-press would be installed and commissioned in an early phase of the project. This would allow the existing wash-press to be removed providing space for the construction of the new headworks channels. Screenings from the existing headworks screens would then be transported to the new wash press with a temporary sluice. Further detail of the wash-press and sluice phasing is presented in Section 3.

2.4.3 Alternative Channel Layout Alternatives

Five (5) alternatives for the layout of the new screenings channels have been developed, as shown in Figure 2-5, Figure 2-6, and Figure 2-7. A descriptive comparison with relative advantages and the engineer's opinion of probable construction cost (EOPCC) of the five alternatives are provided in Table 2-2. The costs include full project costs; detailed EOPCC are included in Appendix D.

SEWRF Preliminary Treatment Upgrades - Preliminary Design Report

THIS PAGE INTENTIONALLY LEFT BLANK

P:\101\Engineering\San_Eljo_JPA\8981_Headworks_Rehab_and_Upgrade\06-Design\CAD\8981.dwg\REPORT FIGURES

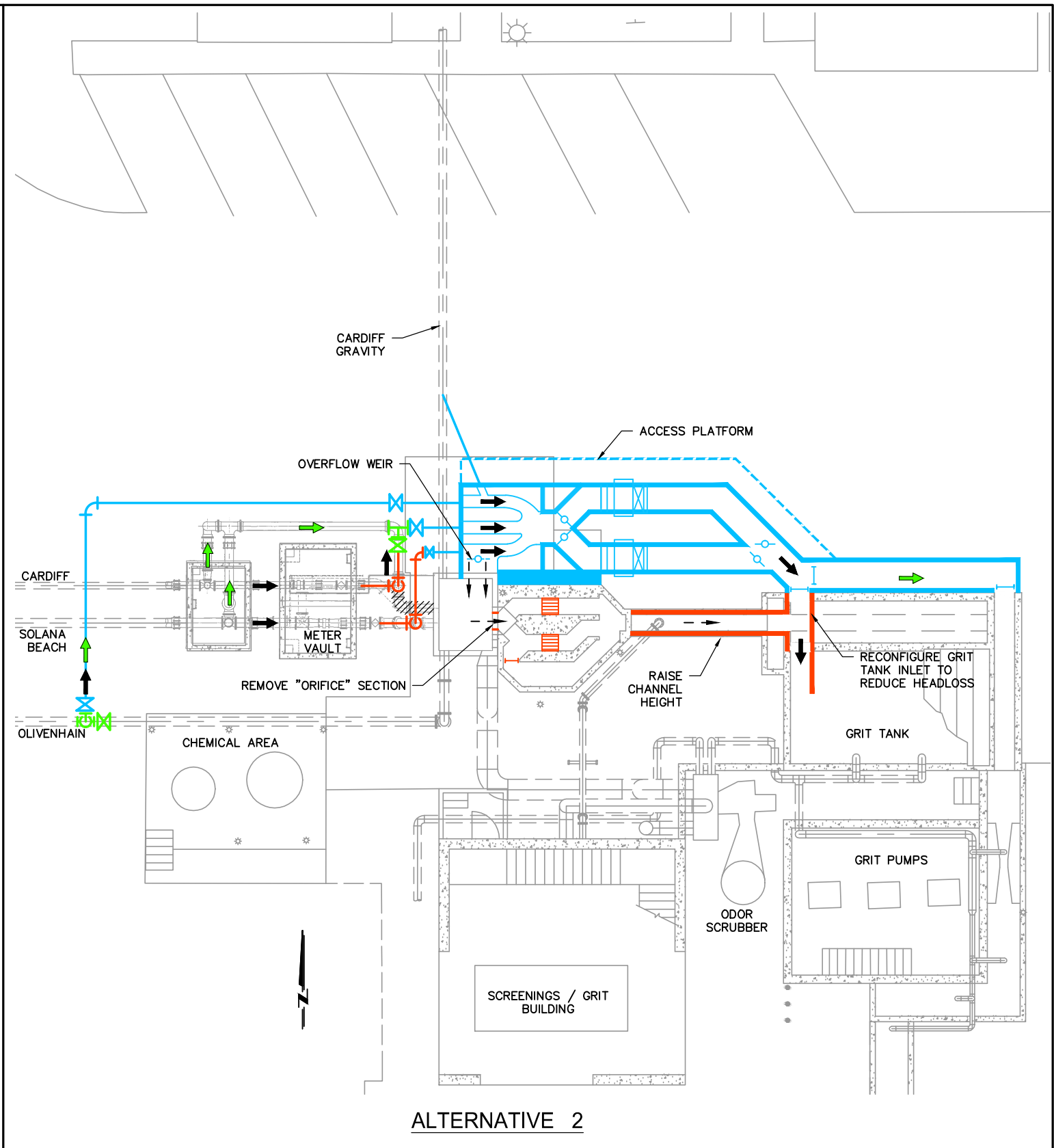
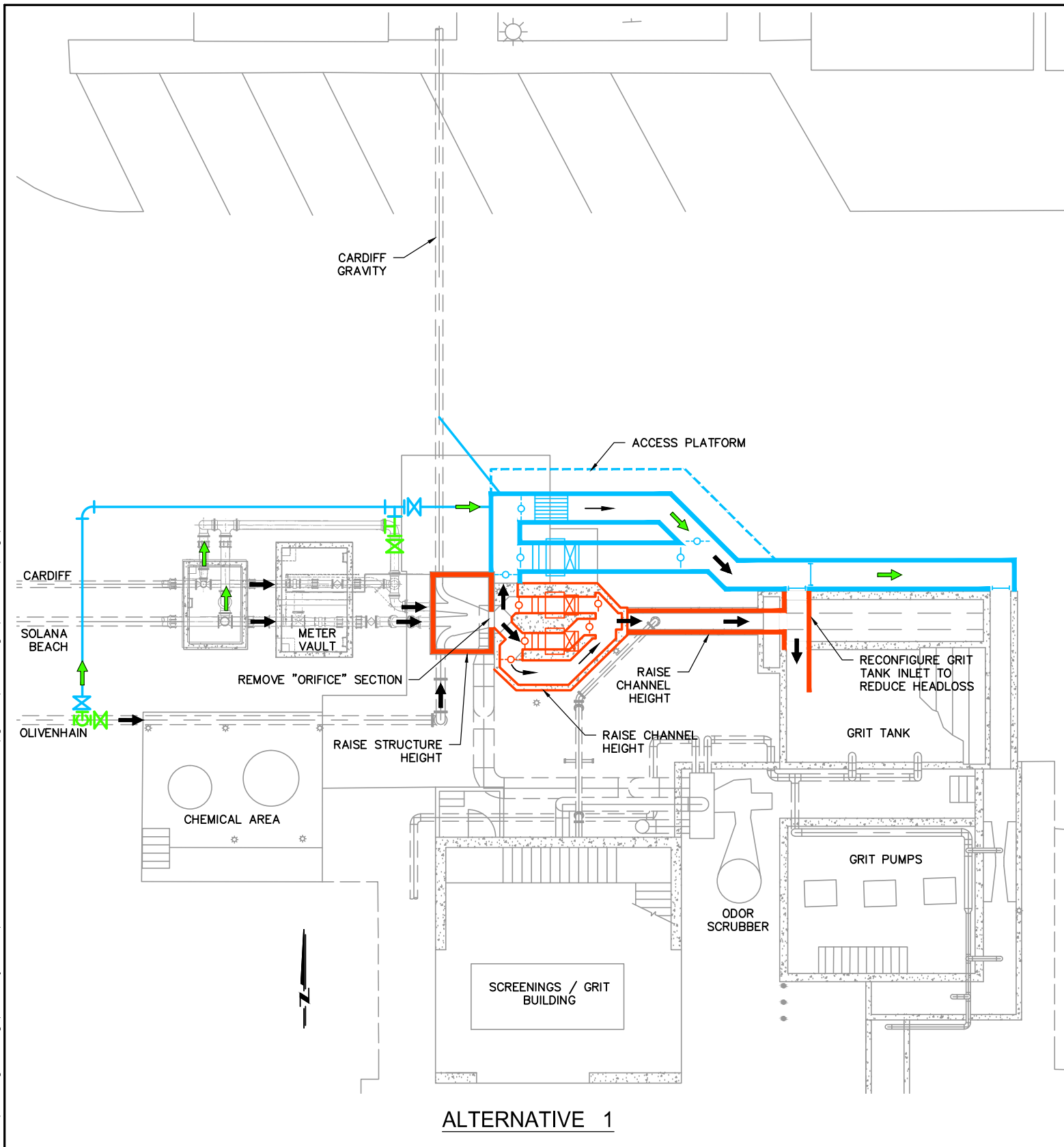

LEGEND:

- PHASE I CONSTRUCTION
- INTERIM PHASE
- PHASE II CONSTRUCTION

- VALVE
- SLIDE GATE
- STOP GATE
- OVERFLOW WEIR / SLIDE GATE
- MANUAL BAR RACK

- MECHANICAL BAR SCREEN
- BY-PASS FLOW PATH
- FINAL FLOW PATH
- FINAL EMERGENCY OVERFLOW PATH

FIGURE 2-5

**LAYOUT
ALTERNATIVES
1 AND 2**

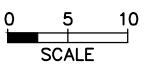

THIS PAGE INTENTIONALLY LEFT BLANK

P:\101\Engineering\San_Eljo_JPA\8981_Headworks_Rehab_and_Upgrade\06-Design\CAD\8981.dwg\REPORT FIGURES

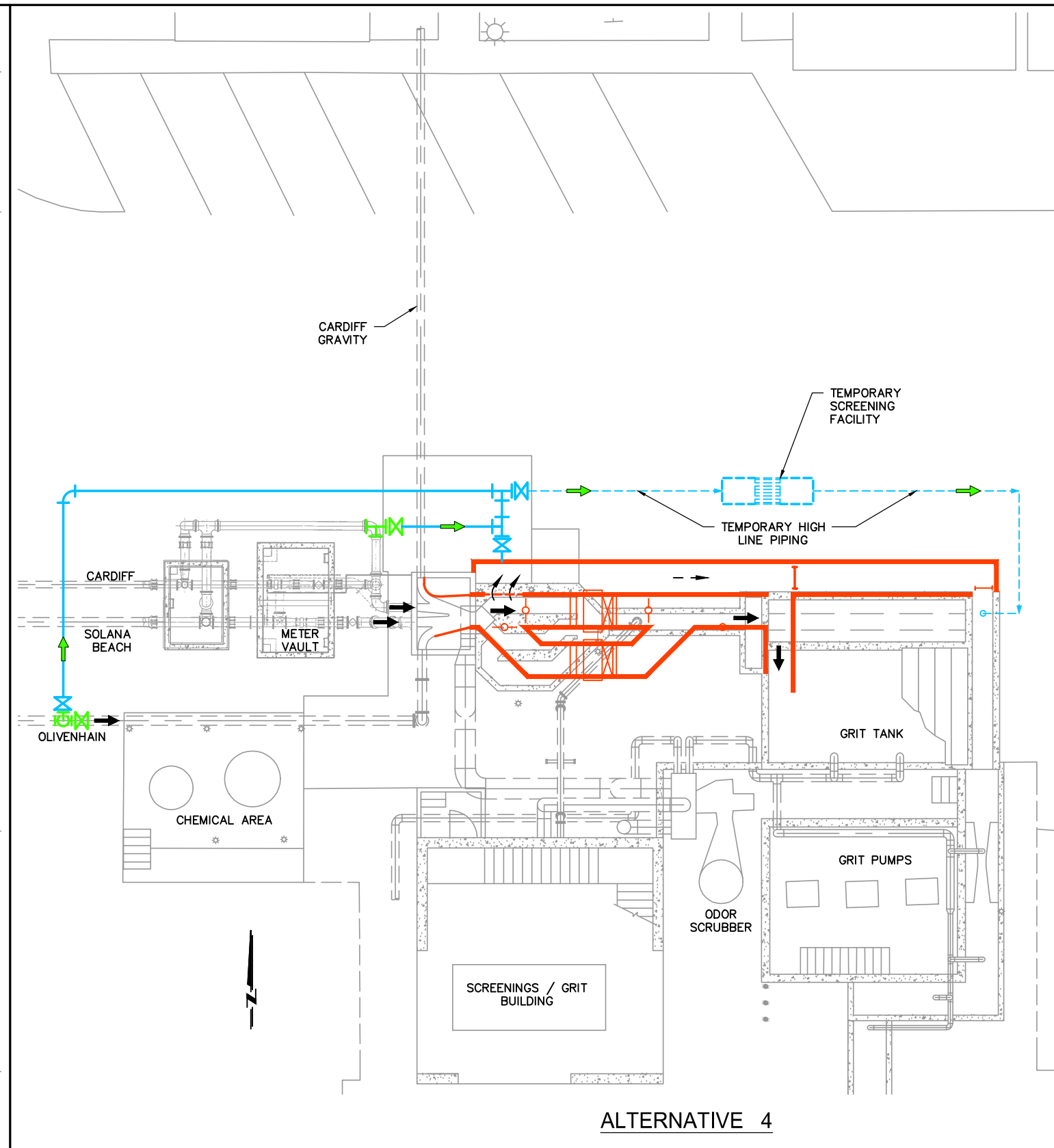
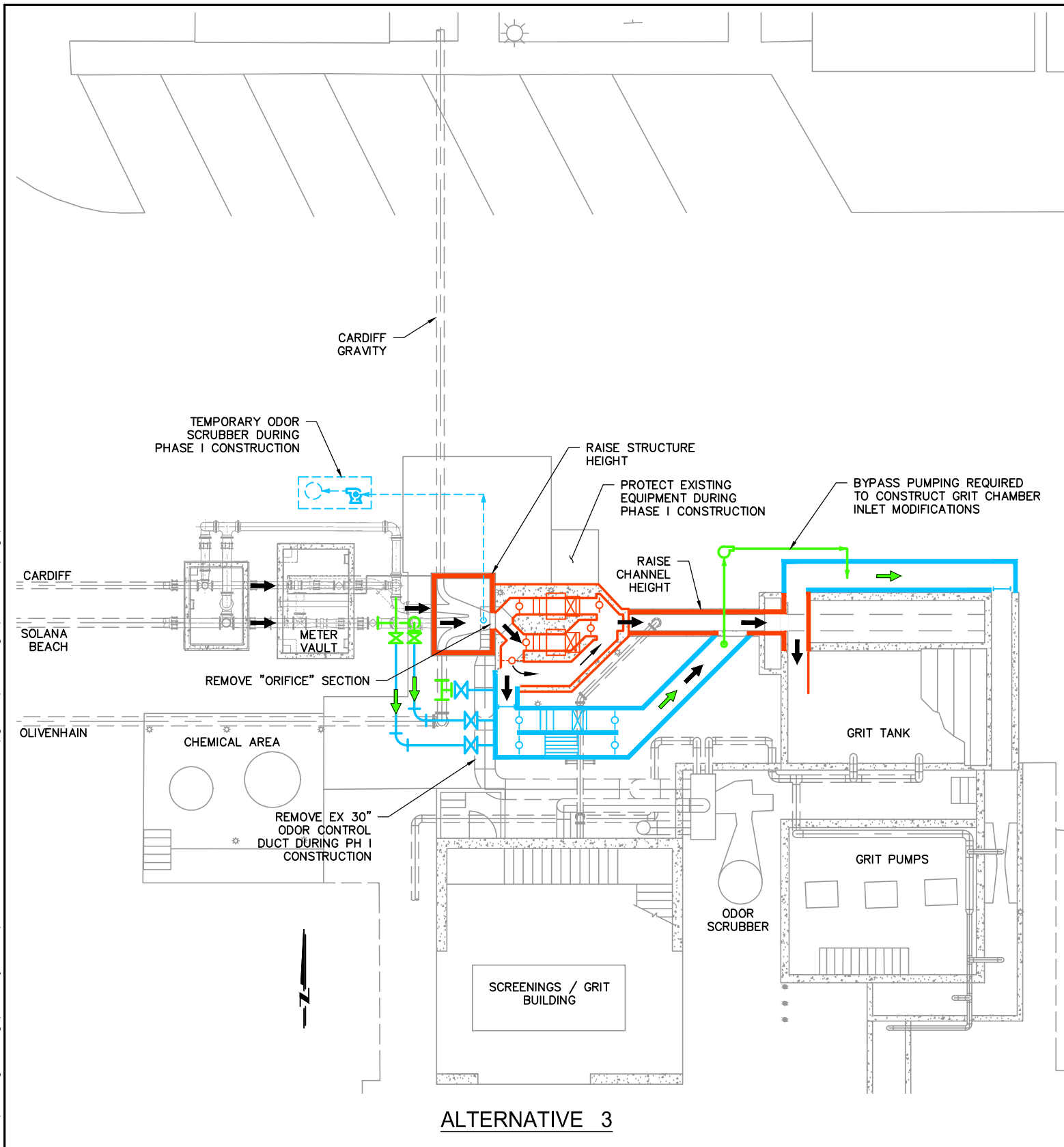

LEGEND:

— PHASE I CONSTRUCTION

— INTERIM PHASE

— PHASE II CONSTRUCTION

⊗ VALVE

○ SLIDE GATE

┆ STOP GATE

—○— OVERFLOW WEIR / SLIDE GATE

▬ MANUAL BAR RACK

▬ MECHANICAL BAR SCREEN

➔ BY-PASS FLOW PATH

➔ FINAL FLOW PATH

—➔— FINAL EMERGENCY OVERFLOW PATH

FIGURE 2-6

**LAYOUT
ALTERNATIVES
3 AND 4**

0 5 10
SCALE

THIS PAGE INTENTIONALLY LEFT BLANK

SEWRF Preliminary Treatment Upgrades - Preliminary Design Report

Figure 2-7: Layout Alternative 5

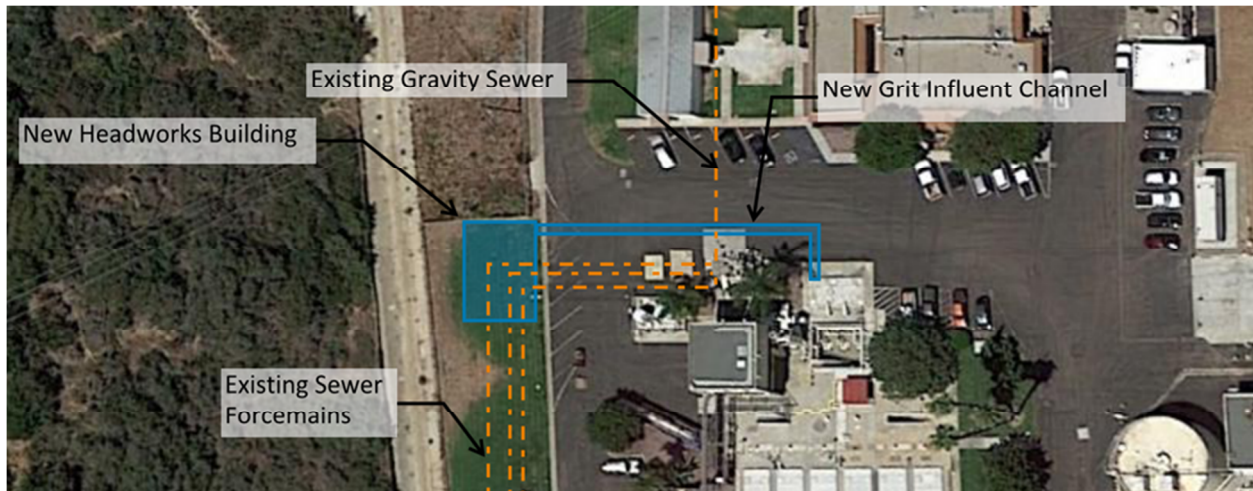

Table 2-2: Channel Layout Alternative Comparison

Alt. No.	Description	Advantages	Construction Cost
1	<ul style="list-style-type: none"> Phase 1 - Construct one (1) new screen channel and one (1) bypass channel in the area to the north side of existing channels each with a capacity of 10.15 MGD. Phase 2 – Raise height of existing screenings channels and structures and install two (2) mechanically cleaned screens in existing channels with a combined capacity of 10.15 MGD. This alternative would reuse the configuration and channeling of the existing Influent Junction Chamber. Additional free board would be added to all existing channels and junction chamber. Hydraulic “pinch-points” in existing channels would be removed to increase flow capacity. 	<ul style="list-style-type: none"> Maintain existing flow path Can fully bypass Headworks 	\$2.59 M
2	<ul style="list-style-type: none"> Phase 1 - Construct new influent junction chamber and two (2) new screen channels in the area to the north side of the existing channels each with a capacity of 10.15 MGD. Phase 2 – Retrofit the existing screenings channels and structures with manually cleaned bar racks for emergency overflow. Remove hydraulic “pinch-points” in existing channels to reduce headloss and to increase flow capacity. The wall height of the grit chamber influent chamber would be raised to add hydraulic free-board. 	<ul style="list-style-type: none"> Less equipment (screens) More direct sluice alignment Lower structure height All screens have same width and flow capacity Improved access to and in between screenings equipment Can accommodate screens that pivot out (e.g. step screens) 	\$2.47 M

SEWRF Preliminary Treatment Upgrades - Preliminary Design Report

Alt. No.	Description	Advantages	Construction Cost
3	<ul style="list-style-type: none"> • Phase 1 - Construct one (1) new 10.15 MGD mechanically cleaned screen channel and manually cleaned bar rack on south side of existing channels. • Phase 2 – Install grit chamber inlet bypass. Install two (2) new 5.075 mechanically cleaned screens in the existing channels. Raise height existing screenings channels and structures. Additional free board would be added to all existing channels and junction chamber. Hydraulic “pinch-points” in existing channels would be removed to increase flow capacity. • This alternative would reuse the configuration and channeling of the existing Influent Junction Chamber. Ducting modifications and temporary odor control would be required. 	<ul style="list-style-type: none"> • Maintain existing flow path • Can fully bypass Headworks • Does not impede driveway to north side of headworks. 	\$2.85 M
4	<ul style="list-style-type: none"> • Phase 1 – Provide full headworks bypass from influent junction structure to grit chamber for entire length of construction of Phase 2. Bypass includes highline piping and temporary screenings facility. • Phase 2 – Demolish existing headworks downstream of influent junction structure. Construct two (2) new mechanically cleaned screen channels and bypass channel with manually cleaned bar rack in the same location as existing channels. The two (2) screen channels would handle 10.15 MGD each as duty and standby. Existing meter vault and forcemains remain in current locations. 	<ul style="list-style-type: none"> • Less mechanical screening equipment • Can install all screenings conveyance and handling equipment at same time • Lower structure height • All screens have same width and flow capacity • All new headworks structure using existing space dedicated to headworks. • Improved access to and in between screenings equipment • Can accommodate screens that pivot out (e.g. step screens) 	\$2.58 M
5	<ul style="list-style-type: none"> • Phase 1 – Re-route three existing forcemains and one recycled water pipeline around new headworks site before construction can begin. • Phase 2 - Construct new headworks building, two (2) mechanically cleaned screen channels each with 10.15 MGD duty/standby capacity and parallel manually cleaned bar rack with 13.6 MGD capacity. New facilities would be located on land west of existing headworks. Construct new odor control system for new building. New headworks building site is on top of existing forcemains and recycled water main. All lines would need to be re-routed to accommodate the new building and headworks location. Construct new valve and meter vault. 	<ul style="list-style-type: none"> • All new headworks building, odor control system, and channels. • New odor control system increases odor control capacity. • Can install all screenings conveyance and handling equipment at same time. • Improved access to and in between screenings equipment 	\$4.28 M

SEWRF Preliminary Treatment Upgrades - Preliminary Design Report

2.5 Channel Layout Alternative Analysis Recommendations

Channel Layout Alternative 2 is recommended for the following reasons:

- Lowest engineers estimate of construction cost
- Duty and standby mechanically cleaned screening units of equal size each of 10.15 MGD versus three units with mixed sizes for other alternatives
- The new mechanically cleaned bar screens can be installed into new channels with a flexible layout providing increased maintenance and operation space.
- Channels layout to allow for pivot-out style screens in both channels.
- The value of the existing channels can be maintained as they would be retrofit as emergency overflow/bypass channels for use during wet weather events
- A temporary bypass screenings facility is not required.

Companion actions are recommended for implementation of Channel Layout Alternative 2:

- Construct two (2) new parallel channels to be 3-feet wide with bottom corner fillets
- Raise height of the Grit Chamber inlet channel to increase freeboard and modify the Grit Chamber inlet channels to use not more than one (1) 90-degree channel bend
- Reuse existing channels for emergency overflow/bypass with modifications to alleviate existing hydraulic constraints

SEWRF Preliminary Treatment Upgrades - Preliminary Design Report

THIS PAGE INTENTIONALLY LEFT BLANK

SEWRF Preliminary Treatment Upgrades - Preliminary Design Report

3 SCREENING REMOVAL AND HANDLING EQUIPMENT

This section of the PDR: 1) describes the existing screenings equipment; 2) provides a condition assessment of the existing equipment; 3) discusses and recommends level-of-service objectives for screenings equipment; 4) reviews available alternative screenings removal and wash press equipment, and 5) recommends replacement equipment for design and construction in the SEWRF project.

3.1 Existing Screening System Description

Screens remove rags, trash, plastics, etc. from the raw wastewater stream to protect downstream processes and equipment. The existing SEWRF Headworks Screening System consists of two (2) separate mechanically cleaned bar screens. These mechanical bar screens automatically rake captured screenings and discharge the screenings into a single wash press. The screen rakes are automatically actuated based on either: 1) high water level differential, as monitored by upstream and downstream ultrasonic level transducers; or 2) adjustable timer settings typically of 10 to 15 minutes. Screenings are then washed and compacted before being discharged into a bin stored outdoors. Operations staff periodically (about every two (2) days) transports and empty the screenings bin into the dumpster located in the Grit and Screenings Building. Under emergency high flow conditions, wastewater diverts to an overflow weir/slide gate and passes through a manually cleaned bar rack installed in the bypass/overflow channel. The existing screenings equipment is further described in Table 3-1.

SEWRF Preliminary Treatment Upgrades - Preliminary Design Report

Table 3-1: Existing Screening Equipment

Parameter	Description
<i>Mechanically cleaned bar screens</i>	
Units installed	2 units (2 duty/0 standby)
Year installed	1989
Equipment type	Reciprocating Rake Bar Screen
Manufacturer/model	Vulcan Industries/Mensch Crawler
Construction material	Frame: Painted Carbon Steel Bar Rack: Stainless Steel
Bar Spacing	3/4-inch
Channel width	2-feet
Motor size	1.5 HP
<i>Screenings wash/press</i>	
Units installed	1 unit (1 duty /0 standby)
Year installed	2003
Equipment type	Agitator/spiral-auger screenings wash/press
Manufacturer/model	Parkson/Heliclean
Construction materials	Stainless steel
Motor size	Spiral-conveyor: 1.5 HP Agitator: 10 HP
<i>Manually cleaned bar rack</i>	
Units installed	1 unit (for overflow/bypass)
Year installed	1981
Construction material	Galvanized Steel
Bar spacing	1-3/8-inch
Channel width	3-feet

3.2 Condition Assessment

The mechanically cleaned bar screens, are about 25 years old and are in poor condition. Moderate corrosion was observed throughout the frame and severe corrosion was observed at the baseplates and discharge chutes. Maintenance staff indicated that the screens are breaking down and jamming more frequently than acceptable. The bar screens are installed without odor control enclosure panels and are therefore open to the atmosphere contributing to noticeable odor release. Moderate corrosion was observed on the manually cleaned bar rack.

The screenings wash/press is in poor condition. Moderate corrosion was observed throughout the unit. Severe corrosion was observed on the agitator motor. The spiral-auger was reported

SEWRF Preliminary Treatment Upgrades - Preliminary Design Report

to have recently broken and been repaired. The unit is reported to be maintenance intensive and rags often wrap and bind the spiral-auger.

The existing mechanically-cleaned bar screens have ¾-inch spacing between bars. Screenings are reported to pass through the existing screens and occasionally clog the primary sludge pumps as well as accumulate in the anaerobic sludge digesters.

The combination of poor equipment condition and no standby screenings equipment increases probability of intermittent failure. Equipment failure could result in “high consequence” wastewater overflow and personnel exposure to raw wastewater and screenings. The combination of high probability of equipment failure and high failure consequences increases the criticality of improving the reliability and redundancy of the Headworks Screening System. Site photographs taken during a June, 2015 field investigation are documented in Appendix A.

3.3 Level of Service Objectives for Screenings Equipment

To improve the level of service of the Headworks Screening System, the existing equipment should be removed and new equipment should be installed. The level-of-service objectives for equipment redundancy and screenings capture will be reviewed to aid in determining the required number of equipment units and equipment type and performance.

3.3.1 Equipment Reliability and Redundancy

The existing screening equipment lacks adequate redundancy. Installing new screenings equipment with adequate redundancy would increase reliability and decrease the probability of failure of the Headworks Screening System. Recommended measures to improve the redundancy of the screenings equipment are presented in Table 3-2.

SEWRF Preliminary Treatment Upgrades - Preliminary Design Report

Table 3-2: Reliability / Redundancy Measures for Screenings Equipment

Equipment	Reliability / Redundancy Measures
Mechanically Cleaned Bar Screens	<ul style="list-style-type: none"> • Install a minimum of one (1) duty mechanically cleaned bar screen and one (1) standby mechanically-cleaned bar screen • Provide an influent wastewater overflow bypass gate and channel to a manually cleaned bar rack for planned or unplanned high upstream water levels
Wash/Press	<ul style="list-style-type: none"> • Install a minimum of one (1) standby wash press for a total of two, duty and standby. Alternative means to manually alternate duty-standby wash presses on weekly / as-needed intervals include: <ul style="list-style-type: none"> ○ Install diverter gate on conveyor/slucice to alternate permanently installed wash presses, or ○ Install wash presses on portable carts allowing wash presses to be alternated by being rolled into position
Conveyor/Slucice	<ul style="list-style-type: none"> • Alternative means to provide full redundancy of the screenings conveyance equipment include the following: <ul style="list-style-type: none"> ○ Install a minimum of one (1) standby screenings conveyor with diverter gates on duty and standby bar screen discharge chutes ○ Install a single screenings slucice (channel designed to convey screenings with process water) with redundant inlet water control valves and flow switches
Instrumentation and Controls	<ul style="list-style-type: none"> • Provide redundant level instruments • Provide automated alarms and controls

3.3.2 Screenings Capture Level of Service

There is 3/4-inch spacing between bars on the existing mechanically cleaned bar screens. Current industry standard practice commonly uses bar spacing as low as 1/4-inch (approximately 6 mm) for raw wastewater. Decreasing the Headworks screen opening size would: 1) increase screenings capture volume; 2) reduce maintenance requirements of downstream equipment; 3) reduce filtration system load; and 4) improve quality of biosolids products (e.g. reduce volume of plastics, trash, etc.).

Decreasing the Headworks screen opening size would also increase screenings capture and would fill collection bins more frequently. The screenings effectiveness of the washing and dewatering/compacting equipment would become increasingly critical as finer screens would remove more organic material and thus generate more putrescible raw screenings with increased odor potential.

Organic material is typically broken up and dispersed when pumped, and thus Headworks with primarily pumped influent, such as SEWRF typically experience less operational issues with organic material capture. For plants of this configuration with influent pumping, a screen opening size of 1/4-inch (or 6 mm) is often recommended as this opening size balances the benefits of higher screenings capture with less organic loading.

SEWRF Preliminary Treatment Upgrades - Preliminary Design Report

The volume of screenings captured and removed from the wastewater stream is expected to at least double by decreasing screen opening size from 3/4-inch to 1/4-inch. However, installing wash-presses with improved compaction capabilities will reduce the washed and compacted volume of screenings to about the same as what the SEWRF is currently experiencing and handling.

The possible equipment layout that would convey screenings to the Grit and Screenings Building with dewatering and discharge directly into a dumpster will be considered. This may further reduce screenings handling requirements of operations staff.

Screenings capture and headloss are inversely relative parameters in screening selection. Both parameters are specific to both the screen type and screen opening size. Figure 3-1 illustrates the relative performance of various mechanically cleaned screen types. For example, perforated plate band-screens are particularly effective at screenings capture; however, they exhibit relatively higher headloss. Whereas, bar screens offer attractive headloss characteristics, even down to 1/4" bar spacing, but conversely are not as effective at capturing screenings material. The relative screenings capture efficiency of the screen types is incorporated into the screen type selection matrix.

Figure 3-1: Relative Performance of Mechanically Cleaned Screen Types

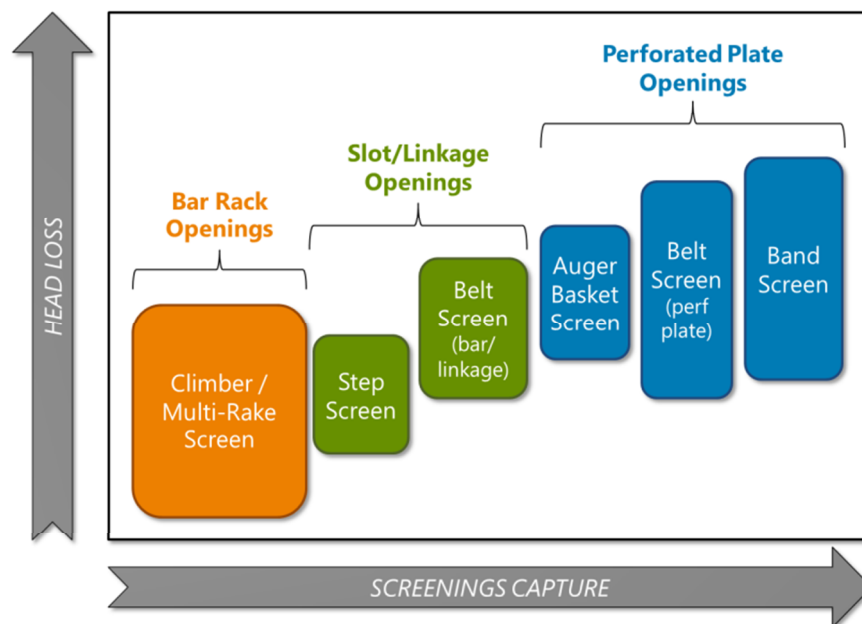

The Headworks reportedly experiences heavy grease loading when the pump stations upstream of the SEWRF are cleaned. We understand that this occurs monthly and that the existing Headworks screens are put into “continuous operation,” rather than timer or differential water level, to avoid blinding from the grease loading. Typically, screens with smaller openings and perforated plate surfaces are more susceptible to “blinding.” Screens with higher cleaning

SEWRF Preliminary Treatment Upgrades - Preliminary Design Report

speeds, and an active cleaning action (e.g. grease is physically scraped from the openings) would be more suitable for heavy grease loading.

3.4 Alternative Analysis of Screenings Removal Equipment

3.4.1 Equipment Overview

In June 2015 the project team met with SEJPA Staff to discuss screen types and gather input on preferred criteria of screening equipment to include in the alternatives analysis. The presentation introducing each screen type, key features, components, and manufacturers is attached in Appendix B. The screen types evaluated in the alternative analysis are as follows:

- Bar screens (reciprocating rake, chain driven multi-rake, and catenary multi-rake)
- Step Screens
- Belt Screens (Slot continuous belt, perforated plate continuous belt, and band screen)
- Basket Screen (Auger Basket Screen and Rotating Basket/Drum Screen)

All screens considered in the screen selection are required to provide the following design features:

- 1/4-inch (6 mm) openings
- Full odor control covers with duct connections
- 316 stainless steel construction

An initial review of the screen types was performed by the project team to determine if the screen types being evaluated would fit physically in the channels, and meet the hydraulic constraints. Manufacturers for each type of screen were requested and did review the channel layouts and design flow rates to determine the applicability of their equipment for this project and to prepare budget pricing.

- Auger basket screens were determined by the manufacturer to not be suitable for the SEWRF design peak flow. The rotating basket screens were determined by the manufacturer to require much wider and longer screen channels for the SEWRF design peak flow. Therefore, basket screens are not further considered in the alternative analysis.
- Band screens were determined by the manufacturer to not be suitable to be installed in 2-foot wide channels, but would be acceptable in 3-foot wide channels.
- Step screens and some continuous belt screens can be pivoted out of the channels to improve maintenance access. The existing Headworks channels do not have sufficient space to allow screens to pivot out. However, the new channels could be constructed with sufficient space to allow a screen to pivot out.

SEWRF Preliminary Treatment Upgrades - Preliminary Design Report

3.4.2 Analysis Criteria

The analysis criteria and weighting factors used to evaluate and compare the different screen types are described in Table 3-3. Analysis criteria were selected based on discussions with SEJPA regarding their objectives for the Headworks. Screens are given a score between one (1) and four (4) for each criterion; higher scores represent more preferable characteristics. The SEJPA has indicated that minimizing operation and maintenance a high priority, and thus the Maintenance Intensity and Grease Blinding Susceptibility criteria are given higher weighting factors.

Table 3-3: Screen Selection Analysis Criteria

Criterion	Description	Weighting Factor
Equipment Cost	Relative cost of equipment from less than \$125,000 (score of 4) to greater than \$175,000 (score of 1)	1
Screenings Capture	Relative screenings capture efficiency from perforated plate (score of 4) to bar rack (score of 1)	1
Grease Blinding Susceptibility	Relative ability of the screen to prevent grease blinding and perform under grease blinding conditions from multi-rake (score of 4) to perforated plate (score of 1)	2
Maintenance Intensity	Relative ease of maintenance for plant staff from no wear parts (climber) (score of 4) to multiple drives/components (belt screen) (score of 1).	2

A summary of the screen type selection evaluation (Evaluation Score x Weighting Factor) is summarized in Table 3-4.

Table 3-4: Screen Evaluation Matrix

Screen Type	Equipment Cost	Screenings Capture	Grease Blinding Susceptibility	Maintenance Intensity	Total Score
Reciprocating Rake Bar Screen	1 x 1	1 x 1	3 x 2	4 x 2	16
Multi-Rake Bar Screen	2 x 1	1 x 1	4 x 2	3 x 2	17
Step Screen	3 x 1	2 x 1	3 x 2	3 x 2	17
Continuous Belt (bar/slots)	4 x 1	2 x 1	2 x 2	1 x 2	12
Continuous Belt (perf. Plate)	3 x 1	3 x 1	1 x 2	1 x 2	10
Band Screen	1 x 1	4 x 1	1 x 2	2 x 2	11

Multi-rake bar screens and step screens both received the highest score and either type is recommended to be installed at the Headworks. Dudek recommends that SEJPA operations and maintenance staff visit multiple installations of multi-rake bar screens and step screens to

SEWRF Preliminary Treatment Upgrades - Preliminary Design Report

verify which equipment best meets their needs and expectations. The final screen selection between these two types is deferred to the final design phase.

3.5 Alternative Analysis of Screenings Conveyance Equipment

A comparison of the available options for conveying screenings to wash-press equipment is presented in Table 3-5. Each type of conveyor type is commonly used to transport raw wastewater screenings, are relatively clean, and can be fully enclosed with odor control panels and duct connections.

Table 3-5: Screenings Conveyance Equipment Comparison

Equipment	Description	Advantages	Equipment Cost ⁴
Screw Conveyors	<ul style="list-style-type: none"> Hardened steel spiral auger installed in u-shaped trough driven by single motor and gear box Can accommodate intermediate drop-off points with bottom slide gates 	<ul style="list-style-type: none"> Wash water not required 	\$47,000 × 2 = \$94,000
Sluice	<ul style="list-style-type: none"> U-shaped trough with automated inlet water valves Can accommodate intermediate drop-off points with diverter gate, or wye fittings and knife gates Installed with overflow piping in case of clogging 	<ul style="list-style-type: none"> Only one (1) unit needed for full redundancy (with redundant inlet water valves and flow switches) Can change horizontal directions with single unit 	\$30,000 × 1 = \$30,000

A sluice is recommended due to the lower equipment costs, need for only one equipment unit, and the ability to change horizontal direction

3.6 Wash-Press Equipment

The following features are recommended for screenings wash-press equipment to ensure good screenings washing and volume reduction:

- Separate Washing and Dewatering zones
- Forward-Reverse Cycles
- Sized to handle screenings (and sluice water) loading

The wash-press manufacturer should match the conveyor and screen manufacturer to ensure controls of each equipment unit is coordinated. Two (2) wash presses (1 duty, 1 standby) are recommended to be installed to ensure full redundancy. Gates should be installed on the conveyor equipment to facilitate alternating duty and standby wash press equipment.

⁴ Costs for approximately 20-foot long conveyor/slucice; equipment only

SEWRF Preliminary Treatment Upgrades - Preliminary Design Report

The existing wash-press is installed outdoors next to the existing screens and dewatered screenings are discharged into a bin which is stored outdoors. Operations staff periodically (about every two (2) days) transport the screenings bin to the Grit and Screenings Building where it is emptied into the dumpster. The new wash-presses could either be installed outdoors near the new screens, or inside the Grit and Screenings Building. Installing the new wash-presses inside the Grit and Screenings Building is recommended for the following benefits:

- Discharge of dewatered screenings to a large common dumpster with the grit, which would reduce screenings handling by SEJPA operations staff
- Improved odor control of wash press and stored screenings

Installing the wash-presses inside the Grit and Screenings Building would require the removal/relocation of the Grit Aeration Blowers, Odor Control Recirculation Pumps, Water Softeners System, and Odor Control Panel. Relocating the odor system control panel is identified in the 2014 Facilities Plan. The water softener system is out of service and the odor control recirculation pumps are reported nearing the end of their useful life; replacement equipment could be installed outdoors near the odor control scrubber (see discussion in Section 6). The grit blowers have been in service about 25 years; the blowers could be replaced with an aeration line from the Secondary Treatment Aeration Tanks air header (See discussion in Section 4).

3.7 Screenings Equipment Phasing

As discussed in Section 2, the existing and new screening equipment will need to be removed and installed in phases to maintain plant operation and allow the new headworks channels to be installed as close as possible to the existing Headworks. The proposed construction steps are illustrated in Figure 3-2 and are described as follows:

- Step 1: Install and commission new wash-presses, half of the sluice, and sluice water valve panel while the existing screening facility remains in operation. Connect temporary hose from valve panel to sluice.
- Step 2: Divert wastewater flow around existing screens and into bypass channel and bar rack. Remove existing wash-press and local control panels, and install temporary sluice extension to run from existing screens to permanent sluice. Route temporary hose from valve panel to temporary sluice. Divert wastewater flow back to existing screens.
- Step 3: Construct new headworks channels and install and commission new screens and remaining section of sluice. Install permanent plant water piping from valve panel to final upstream end of sluice. Divert wastewater flow to new headworks channels and screens.
- Step 4: Remove temporary sluice extension and existing screens, and rehabilitate concrete channels and install manual bar racks.

SEWRF Preliminary Treatment Upgrades - Preliminary Design Report

Figure 3-2: Screenings Equipment Phasing Plan

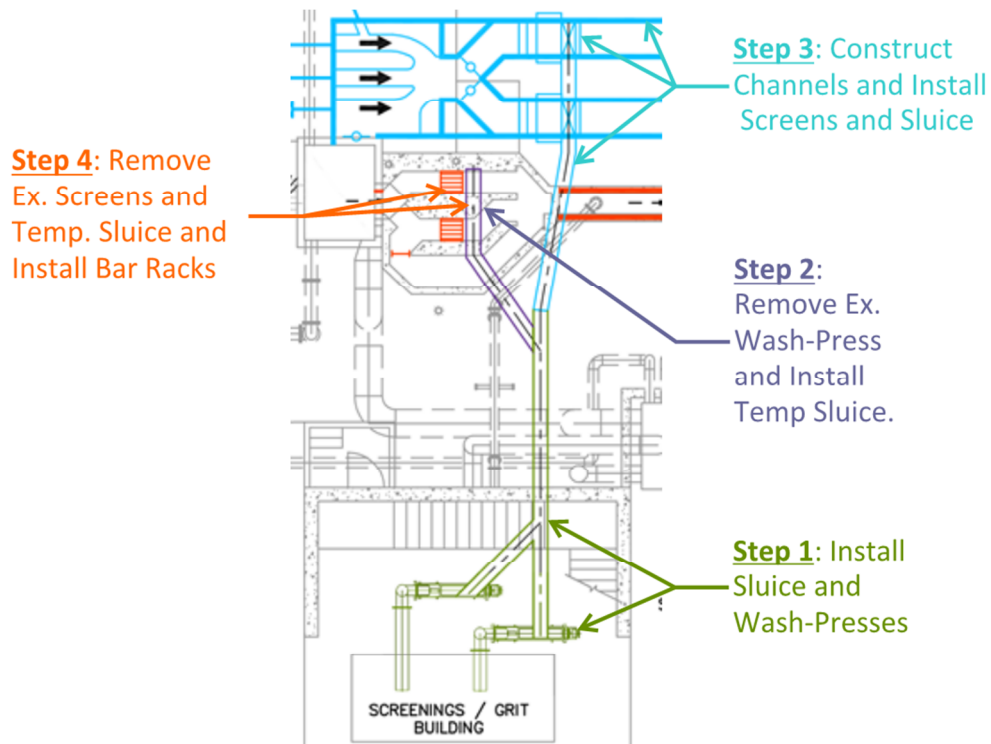

3.8 Water Usage

The existing wash-press is reported to currently use about 15 acre-feet per year (13,390 gallons per day) of plant water. The new wash-press and sluice combined are anticipated to use approximately 5.6 acre-feet per year (5,000 gallons per day).

3.9 Recommendations

Based on the above review, comparison, and analyses, the following actions are recommended for the screenings removal and handling system:

- Installation of new multi-rake bar screens or step screens with at least one (1) standby unit
- Installation of a single screenings sluice conveyor with redundant inlet water valves and diverter gates at the discharge
- Installation of a two (2) wash presses in the existing Grit and Screenings Building

SEWRF Preliminary Treatment Upgrades - Preliminary Design Report

4 GRIT REMOVAL EQUIPMENT

This section of the PDR: 1) describes the existing grit removal equipment; 2) provides a condition assessment of the existing equipment; 3) provides a grit removal evaluation; 4) provides an analysis of possible removal of the grit aeration blowers; and 5) recommends grit removal improvements for design and construction in the SEWRF Headworks project.

4.1 Existing Grit Removal Equipment

Screened wastewater flows from the screenings area through concrete open channels to an aerated grit chamber. Two (2) aeration blowers installed in bottom floor of the Grit and Screenings Building supply air to the grit chamber diffusers. Grit which settles in the aerated grit chamber hoppers are pumped out by three (3) grit pumps to the two (2) grit classifiers installed on the top floor of the Grit and Screenings Building. The classifiers separate water and organics from the grit and discharge the grit into a dumpster on the first floor of the building. All grit equipment is currently operated continuously. However, the grit pumps could be operated based on timer settings, and the grit classifiers operate when the grit pumps are on. The existing grit removal equipment is further described in Table 4-1.

Table 4-1: Existing Grit Removal Equipment

Parameter	Description
Aerated Grit Chamber	
Units installed	1 units (1 duty/0 standby)
Year installed	1964
Chamber length	24-feet
Chamber width	16.5-feet
Chamber depth	11.5-feet
Equipment type	Coarse Bubble Diffusers
Construction material	Diffusers: PVC Air Piping: PVC
Number of Diffusers	22
Grit Blowers (Positive Displacement)	
Units installed	2 units (1 duty/ 1 standby)
Year installed	1989
Manufacturer/model	Gardner Denver Sutorbilt
Construction material	Cast Iron
Motor size	7.5 HP
Grit Pumps	
Units installed	3 units (2 duty / 1 standby)

SEWRF Preliminary Treatment Upgrades - Preliminary Design Report

Year installed	1989
Pump type	Recessed Impeller Vortex Pump
Manufacturer/model	Hayward Gordon Ltd. / XR3(11)
Design Capacity / Head	200 gpm / 61 ft
Construction material	NiHard 28% Chrome Iron
Motor size	10 HP
Grit Classifiers/Cyclones	
Units installed	2 units (1 duty / 1 standby)
Year installed	2003
Equipment Type	Cyclone Separator + Dewatering Classifier
Manufacturer/model	WEMCO Hydrogritter
Classifier Size	12 inches
Construction material	Stainless Steel (Classifiers) and Cast Iron (Cyclones)
Motor size	1.5 HP

4.2 Condition Assessment

The grit pumps, blowers, and classifiers are reported to operate satisfactorily. Minor coating deterioration was observed on the grit pumps. One of the blowers was removed; minor coating deterioration and corrosion was observed on the remaining grit chamber blower, piping and silencers. Moderate corrosion was observed on the stainless steel grit classifiers. The grit classifiers do not have odor control covers or ducting and are open to the building air space. De-lamination and moderate to severe corrosion was observed on the grit bin hoppers/chutes. The hopper gates are prone to jamming are now always left in the open position.

Condition assessment of the structural components (e.g. concrete and covers) of the grit chamber is presented in Section 5.1. The ductile iron grit piping, PVC air piping, diffusers, and supports inside the grit chamber were observed to be in good, serviceable condition. The grit chamber hopper/sumps are prone to grit buildup and SEJPA staff pump out the sumps and clean the grit chamber about once per year. Site photographs taken during a June, 2015 field investigation are documented in Appendix A.

4.3 Grit Removal Evaluation

The original plant drawings (County of San Diego, 1964) provide space and knock-out walls in the channels for a second aerated grit chamber. Based on the data presented in Table 4-2, the SEWRF grit chamber is adequately sized for operation at a peak flow of 13.6 MGD. Based on operational data, the amount of grit accumulated in the digesters suggests that the Grit Chamber removal efficiency is satisfactory.

SEWRF Preliminary Treatment Upgrades - Preliminary Design Report

Table 4-2: Grit Chamber Design Criteria

Design Criteria	Unit	Typical ⁵	SEWRF
Detention Time at Peak Flowrate	min	2-5	3.67 ⁶
Air supply per unit of length	cfm/ft	3-8	6 ⁷

4.4 Grit Aeration Blowers Elimination Analysis

The grit blowers are approximately 25 years old and expected to be reaching the end of their useful life. The secondary treatment aeration system is reported to have excess capacity air flow capacity. To free up space in the Grit and Screenings Building (e.g. for screenings wash presses), the blowers could be removed and an aeration line could be installed from the aeration tank air header to the grit chamber. The grit air pipe would be stainless steel, about 4-inch in diameter, and could be routed above grade on the side of the existing structures as shown in Figure 4-1. The pressure in the aeration basin air header is sufficient to provide air to the Grit Chamber.

Figure 4-1: Grit Piping Alignment

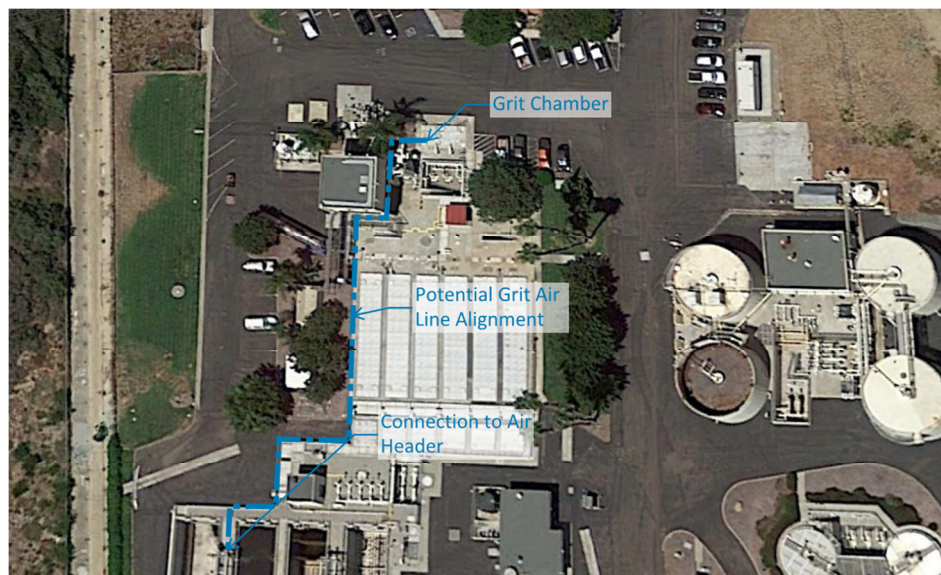

The life-cycle cost of new stainless steel aeration line is comparable to installing new grit blowers with sound enclosure. Installing the new grit air pipe in lieu of new blowers would have the advantage of eliminating two (2) assets, freeing up space in the motor control centers (MCCs), and reducing maintenance costs and time.

⁵ Wastewater Engineering, Metcalf and Eddy, 5th ed. 2014

⁶ Based on 13.6 MGD

⁷ Based on 1964 County of San Diego Drawings

SEWRF Preliminary Treatment Upgrades - Preliminary Design Report

4.5 Recommendations

The following actions are recommended for the grit removal systems:

- Have the classifier manufacturer, WEMCO, retrofit the existing classifiers in the field with the new gasketed odor control panels
- Install odor control ducting for grit classifiers
- Install a new grit aeration piping fed from the aeration tanks air header to replace the grit aeration blowers
- Remove the existing grit aeration blowers
- Rehabilitate the grit chamber concrete coating
- Replace the grit chamber covers per Section 5.5.

5 STRUCTURAL

This section of the report: 1) describes the existing structural and coating materials; 2) provides a condition assessment of the existing equipment; 1) reviews the existing condition of structural concrete and concrete coatings in the Headworks area, presents structural rehabilitation measures; 3) determines structural modifications necessary for adding additional height to the existing concrete channels; 4) reviews cover types appropriate for channels and Grit Chamber; and 5) recommends structural improvements for design and construction in the SEWRF Headworks project.

5.1 Existing Structural and Coating Materials

The existing Influent Junction Chamber, Headworks channels, and Grit Chamber are all constructed of reinforced concrete with aluminum covers. The interior surfaces of the concrete channels south of the existing screens, as well as the upper 4-feet of the grit chamber appear to have a spray-applied polyurethane coating. The channels downstream of the grit chamber area also have a coating, but the type is unknown. The channels are installed with aluminum stop plates at channel junctions.

5.2 Condition Assessment

Areas of the channels with little or no odor control ducting show the most coating failure and concrete corrosion. Minimal to no concrete corrosion was observed at the Influent Junction Chamber and upstream sections of the screen channels. Severe coating failure and concrete corrosion with exposed aggregate was observed on sections of the channels near the Grit Chamber inlet and effluent weir; however, no exposed rebar was observed. The other areas of the channel coatings were observed to be in fair condition with approximately 30% of the area experiencing coating failure (e.g. cracking, peeling) coating. The majority of the cover recesses for the aluminum covers were observed to be fair condition; it is expected that the majority of which will need to be replaced to facility concrete rehabilitation. The aluminum covers of the channels were observed to be in good condition. The aluminum frames installed near the Grit Chamber are corroded and deformed.

The grit chamber was observed to be in good condition with the exception of the extruded aluminum covers. The aluminum covers over the Grit Chamber only were observed to be heavily corroded, especially at the edges of the cover plates where the aluminum has been corroded into frayed, weak edges. Additional localized corrosion has corroded away holes in the top of the aluminum covers. All of the covers require immediate repair or replacement. The grit chamber concrete was observed to be in good condition, with only minor erosion of the substrate near the water surface. The concrete is stained black, presumably due to the upstream addition of ferric chloride, which is not expected to compromise the concrete or coating.

SEWRF Preliminary Treatment Upgrades - Preliminary Design Report

The Grit and Screenings Building was observed to be in good condition with no observed cracks or corrosion. Site photographs taken during a June, 2015 field investigation are documented in Appendix A.

5.3 Structural Rehabilitation

All existing coating material, dirt/grease, and deteriorated concrete should be removed by use of high pressure water blast or scabber. Reinforcing steel which is exposed after concrete removal should be mechanically cleaned, high-pressure washed, and applied with an anti-corrosion primer. A polymer-modified concrete repair mortar should be applied per the manufacturer's recommendations to rehabilitate the concrete surface. Once the mortar is cured, an epoxy or polyurethane (type to be determined during final design) coating designed specifically for wastewater structures should be applied to protect the concrete from future corrosion.

The extent and depth of surface preparation and quantity of repair mortar will vary depending on the extent of concrete and reinforcement corrosion, which varies between the different Headworks channel areas. Based on field investigations, the majority of the concrete surfaces will require removal of the existing coating and surface preparation for application of the new coatings. Bid quantities of the concrete rehabilitation types will be determined in final design. Bid items will use square foot unit prices and will have conservative allowances to accommodate unforeseen concrete conditions.

Where necessary to facilitate concrete rehabilitation and coating, rebate embeds for the channel covers will be replaced.

5.4 Structural Modifications

The wall heights of the existing Headworks channels are required to be raised depending on the hydraulics of the layout alternative selected. The feasibility of increasing the height of the existing 8-inch thick reinforced concrete walls for Headworks channels was evaluated.

Structural analysis determined reinforcing struts would be required for increases in wall height of more than 1-foot and up to 3.5-feet (above original 1964 construction height); reinforcing struts are not required for raising the wall heights 1-foot or less. The reinforcing struts would be Type 316 stainless steel "C" channel or angles, cast into the tops of the proposed additional concrete wall sections, spanning the channel, and with wall anchors. These reinforcing struts would be provided to restrain the top of the walls to counteract the increase in hydrostatic pressure due to higher water depths.

Concrete soundness would be verified during the construction of any modifications, as required by the contract specifications. This verification would be conducted during the drilling to set and epoxy new rebar into the top of the existing concrete walls. Sand blasting the top of wall to

SEWRF Preliminary Treatment Upgrades - Preliminary Design Report

1/4 -inch roughness amplitude would also be required to ensure a bond between existing and new concrete. All soft and incompetent concrete would be removed and replaced.

5.5 Channel and Grit Chamber Covers

The existing aluminum grit chamber covers have been in service for over 25 years. It is recommended that the existing corroded aluminum tank covers be replaced with new aluminum tank covers. Aluminum covers over the channels were observed to be in good condition and suitable for covering headworks channels. New channels will be installed with un-punched aluminum plank grating, which can span longer distances while remaining relatively light weight. Figure 5-1 shows an example of an un-punched aluminum plank grating installation.

Figure 5-1: Un-Punched Aluminum Plank Grating

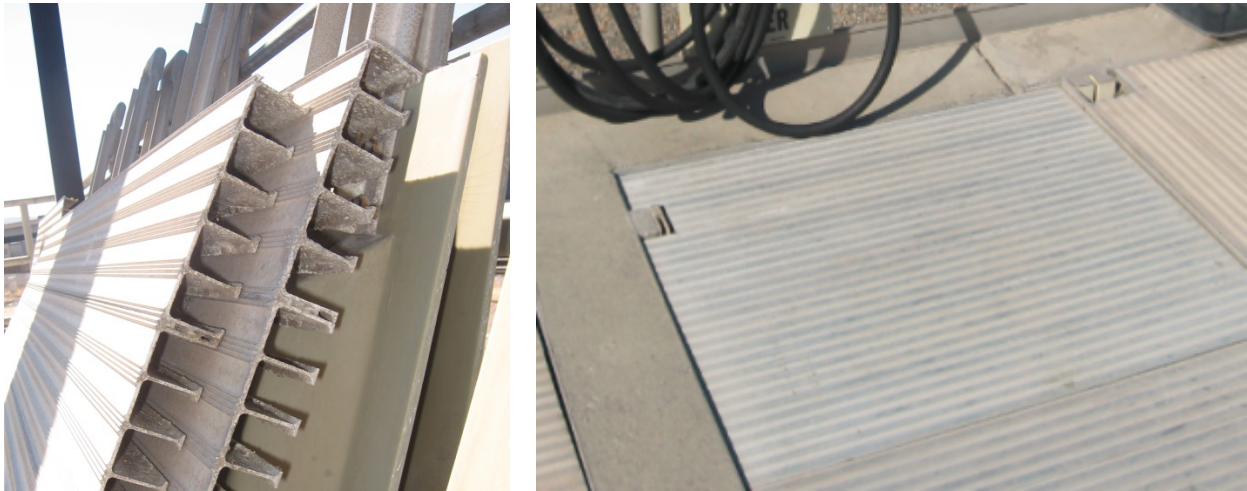

5.6 Structural Recommendations

The following is recommended for implementation as part of the Headworks project:

- Rehabilitate and recoat all existing inside faces of concrete channels and upper 4-feet of grit chamber
- Coat all inside faces of new concrete channels
- Raise channel heights as necessary based on selected layout alternatives; add reinforcement struts as required.
- Install un-punched aluminum plank grating over new channels
- Replace existing aluminum Grit Chamber covers

SEWRF Preliminary Treatment Upgrades - Preliminary Design Report

THIS PAGE INTENTIONALLY LEFT BLANK

6 ODOR CONTROL SYSTEMS

The headspace of the Grit and Screenings Building, Influent Junction Chamber, Grit Chamber, sections of the grit effluent channels, the primary scum pit wet well, and wash press inlet hoppers are connected to odor control ducting and are mechanically ventilated by a centrifugal exhaust fan discharging into the Headworks Odor Scrubber. The Headworks channels at bar screen entrance and at the Grit Chamber do not have aluminum covers for odor containment.

This report section: 1) describes the existing odor control equipment; 2) provides a condition assessment of the odor control existing system; 3) provide evaluation of relocating odor control equipment; 4) recommends odor control measures during construction; 5) reviews existing foul air duct flowrates and ventilation rates; 6) evaluates capacity of existing odor control scrubber; and 7) recommends improvements and optimization measures to the Headworks odor control system, as well as evaluating the feasibility of treating foul air from new areas (e.g. headspace of new Headworks channels, Primary Influent and Effluent Channels) with the existing Headworks scrubber.

6.1 Existing Odor Control Equipment

The odor scrubber system is a wet chemical scrubber with one (1) exhaust fan, two (2) recirculation pumps, a caustic soda and sodium hypochlorite chemical tanks and feed pumps, and a water softener system. The SEWRF currently does not use the sodium hypochlorite pumps, and the water softener system is out of service. The use of reclaimed water, with a chlorine residual, has reportedly allowed SEWRF staff to move away from using sodium hypochlorite in the scrubber.

The odor control scrubber and fan are installed just east of the Grit and Screenings Building, the chemical tanks and pumps are located to the west of the Building, and the recirculation pumps and odor control panel is installed on the bottom floor of the Building. The odor control system was installed in about 1989. The existing odor control equipment is further described in Table 6-1.

SEWRF Preliminary Treatment Upgrades - Preliminary Design Report

Table 6-1: Existing Odor Control Equipment

Parameter	Description
Wet Chemical Scrubber Tower	
Units installed	1 units
Construction material	Fiberglass Reinforced Plastic (FRP)
Current Air Flowrate	9,945 cfm
Diameter	5 feet
Exhaust Fan	
Units installed	1 unit
Construction material	Fiberglass Reinforced Plastic (FRP)
Motor size	10 HP
Recirculation Pumps	
Units installed	2 units (1 duty/ 1 standby)
Pump type	Horizontal Fiberglass Pump
Manufacturer/model	Fybroc / Series 1500 (2x3x8)
Motor size	5 HP

6.2 Condition Assessment

The odor control scrubber, ducting, and fan, were observed to be in good condition, and no reoccurring performance deficiencies have been reported by plant staff. Some corrosion was observed on the FRP ducting near the Grit Chamber. Moderate corrosion was observed on the exhaust grill in the bottom floor of the Grit and Screenings Building. The scrubber recirculation pumps at the headworks are reportedly nearing the end of their useful lives, as repair parts are available but just as costly as a new pump. The recirculation pumps do not have a failure alarm linked to SCADA. The water softener system is out of service and the scrubber is reported to have scaling buildup. The odor control scrubber has an air quality permit and reportedly is in compliance.

Foul odors are noticeable around the screenings equipment, and inside the Grit and Screenings Building. The bar screens are not covered, the grit classifiers do not have odor control containment panels, the screenings effluent channels and Grit Chamber inlet and effluent channels are not connected to the odor control ductwork, and the Grit and Screenings Building appears to be experiencing ventilation short-circuiting and air balancing issues (single intake louver and exhaust grill). The lack of ventilation on some of the Headworks channels may be contributing to observed corrosion (i.e. hydrogen sulfide corrosion) of the concrete channels in these areas.

SEWRF Preliminary Treatment Upgrades - Preliminary Design Report

6.3 Equipment Relocation

Installing the wash-presses inside the Grit and Screenings Building will require the removal/relocation of the Odor Control Recirculation Pumps, Water Softeners System, and Odor Control Panel. Relocating the odor system control panel is identified in the 2014 Facilities Plan; it is recommended to be installed under a shade canopy on the north side of the Chemical Area. New odor control recirculation pumps and water softener system could be installed outdoors near the odor control scrubber.

6.4 Odor Control During Construction

Connecting new foul air FRP duct to the existing duct system will require isolation and shutdown (e.g. close damper) of the existing duct and thus temporary odor control will be required for the duration of the duct shutdown. Layout Alternatives 3 and 4, as discussed in Section 2, will require temporary odor control for multiple months. A temporary packaged carbon scrubber system complete with a fan and control panel, and size accordingly can be rented as needed. Detailed requirements for the Contractor to furnish and setup a temporary packaged odor control system and ducting during construction will be further developed during final design.

6.5 Existing Odor Control System Flowrates

Air flowrates for the Headworks odor control scrubber and duct work were previously measured as part of the *Odor Control Operational and Optimization Strategies*, DHK Engineers, Inc., 2015. The air flowrate measured at the discharge of the odor scrubber centrifugal fan was 9,945 cfm. The measured air flow rates for the existing Headworks odor control system and corresponding calculated ventilation rate, in air changes per hour (ACPH), are presented in Table 6-2.

Table 6-2: Existing Odor Control Air Flowrates and Ventilation Rates

Ventilation Location	Flow Rate (cfm)	Ventilation Rate (ACPH)
Unoccupied Spaces		
Influent Junction Chamber	2,110	268
Grit Chamber (Combined)	685	41
Grit Effluent Channels (Combined)	775	39
Scum Wet Well	180	11
Occupied Spaces (Grit and Screenings Building)		
Bottom Floor	1,930	9
Top Floor	4,265	25
Average Building Ventilation Rate	N/A	16
Total		
Total Air Flowrate	9,945	N/A

SEWRF Preliminary Treatment Upgrades - Preliminary Design Report

6.6 Odor Scrubber Loading Evaluation

The existing odor control scrubber is a packed bed gas absorption scrubber. Typical design criteria for similar packed tower scrubbers for odor control at wastewater treatment plants treating hydrogen sulfide per the *Control of Odors and Emissions from Wastewater Treatment Plants*, Water Environment Federation Manual of Practice 25 were compared the existing operation and the results are summarized in Table 6-3. The scrubber exceeds the typical design criteria for empty bed gas velocity, and gas loading rate. However, the scrubber is reportedly operating satisfactory and is in compliance with its air quality permit. The odor control scrubber appears to be at capacity and it is not recommended to increase the flow rate to the scrubber system.

Table 6-3: Odor Scrubber Design Criteria

Parameter	Unit	Typical Value	SEWRF Value
Air flow rate	cfm	N/A	9,945 ⁸
H ₂ S concentrations	ppm	N/A	0.16 / 19.9 / 42 ⁹
Tower diameter	ft	N/A	5
Empty bed gas velocity	ft/min	300 to 500	506
Packing depth	ft	6 to 12	10
Gas loading rate	lb/sqft/h	1,800 to 2,250	2,683 ¹⁰
H ₂ S loading rate	lb/h	N/A	0.01 / 1.05 / 2.21 ^{11,12}
Makeup water flow rate	gpm/1000 cfm	0.1 to 1.0	0.1

6.7 Odor Control Optimization

To minimize odors, headworks channels and equipment should be enclosed and a fan needs to draw of the headspace at a high enough air flowrate to induce a negative pressure sufficient to keep odors from escaping; a negative pressure of 0.1 inches of water column is typical. To minimize corrosion, the enclosed headspace needs to ventilated enough to dilute accumulating gases such as hydrogen sulfide; common design ventilation rates for enclosed, unoccupied spaces at Headworks is six (6) air changes per hour (ACPH) and 12 to 30 ACPH for occupied spaces. Tanks with diffused aeration should have exhaust foul air flowrates approximately 10% higher than the aeration flow rate to maintain sufficient negative pressure.

⁸ *Odor Control Operational and Optimization Strategies*, DHK Engineers, Inc., 2015

⁹ *Representing Minimum / Average / Maximum channel headspace H₂S concentration as measured in SEJPA's 1998 Engineering Services for Odor Control Upgrades Report.*

¹⁰ *Gas loading rate calculated assuming 70 degree Fahrenheit ambient air temperature.*

¹¹ *H₂S loading rate calculated assuming 70 degree Fahrenheit ambient air temperature.*

¹² *Representing Minimum / Average / Maximum H₂S loading rates calculated using channel headspace H₂S concentrations as measured in SEJPA's 1998 Engineering Services for Odor Control Upgrades Report.*

SEWRF Preliminary Treatment Upgrades - Preliminary Design Report

As shown in Table 6-2, the ventilation rate for the bottom floor of the Grit and Screenings Building is less than recommended which is likely contributing to the elevated odors in the building. Multiple enclosed areas have ventilation rates above recommended values; if the containment (e.g. gasketed odor control covers on all equipment and channels) is improved, ventilation rates in these areas could be reduced while still improving odor control. Additionally, installing additional duct connections where none exist (bar screens, grit classifiers, screenings effluent channels, and Grit Chamber inlet and effluent channel), and rebalancing the ducting will improve Headworks odor control. To further improve the odor control in the Grit and Screenings Building, additional intake louvers, exhaust ducting could be added improve distribution and prevent short-circuiting; exhaust hoods could also be added (space permitting) above the dumpster to better capture odors.

Rebalancing (e.g. adjust dampers) and optimizing the odor control ducting for new and existing enclosed, unoccupied spaces at the Headworks to maintain 6 ACPH, or 10% higher flowrates than aeration, will allow the total Grit and Screenings Building ventilation rate to be increased to approximately 24 ACPH. Adding the Primary Influent and Effluent channels would require the Grit and Screenings Building ventilation rate to be approximately 23 ACPH.

6.8 Recommendations

The following actions are recommended for the odor control systems:

- Replace exhaust grill on bottom floor of Grit and Screenings Building.
- Install new odor control recirculation pump and water softener system outside near the existing scrubber.
- Install new odor control local control panel outdoors under new shade canopy on north side of Chemical Area.
- Add requirements for temporary odor control scrubber during construction to final specification.
- Do not increase air flowrate of the existing Headworks scrubber
- Add channel covers to Screen Influent Channels
- Add gasketed odor control panels to the new bar screen
- Add gasketed odor control panels to the existing grit classifiers (see Section 4)
- Add foul air duct connections to all screens, classifiers, and sluice
- Add additional duct connections to existing screenings effluent channels, and Grit Chamber inlet and effluent channel
- Add duct connections to new Headworks channel covers
- Add additional intake louvers and exhaust ducting/grills/hoods to Grit and Screenings Building to improve distribution and prevent short-circuiting
- Rebalance foul air ducting to maintain 6 ACPH, or 10% higher flowrates than aeration, in enclosed, unoccupied spaces, and 24 ACPH for Grit and Screenings Building.

SEWRF Preliminary Treatment Upgrades - Preliminary Design Report

THIS PAGE INTENTIONALLY LEFT BLANK

SEWRF Preliminary Treatment Upgrades - Preliminary Design Report

7 ELECTRICAL

7.1 General

The headworks and adjacent Grit building equipment is powered by the MCC building constructed in 2011. This MCC Building is located at southwest of the grit building. The air conditioned MCC building houses MCC-A and MCC-B along with a PLC (LCP-PS). Both MCC A and B can accommodate the proposed Headworks upgrades without physical expansion. By phasing the project, existing MCC motor starters can be reused or replaced in the same physical spaces. Existing MCC space is available for a Bar Screen No. 3 starter, if needed. The net load on the MCC's will be reduced after the upgrade. Therefore MCC capacity (loading) is not a concern. The existing site standby generator will not be impacted.

7.2 Power Distribution

The 2011 Facility Electrical Upgrades Project transferred electrical loads from the Headworks to the new MCC building. Conduits between the headworks area/Grit building are mostly exposed and supported by the building and overhead conduit racks. Underground conduits originating in the MCC building stub above grade about 20 feet from the MCC building onto a conduit rack (see Figure 7-1). The conduits associated with the removal and addition of equipment can be intercepted and extended to new locations as required. Conductors may be pulled back to upstream pull boxes and reutilized where lengths are sufficient. Some new conductors may have to be pulled back to the MCC (i.e. for a third Bar Screen) if needed.

The record drawings show small pull-boxes and conduit runs just to the north of the headworks area. These conduits may have been abandoned during the past upgrades. However these conduits and circuits should be closely investigated and traced during final design so they may be relocated in an early part of the construction phasing for the Headworks Upgrade Project.

7.3 Odor Control Panel (LCP-ORH)

The headworks odor control panel is located inside the Grit and Screenings Building. SEJPA has requested that this panel be removed from the Grit building. The panel controls the grit

Figure 7-1: Conduit Rack



SEWRF Preliminary Treatment Upgrades - Preliminary Design Report

building exhaust fans and pumps along with the scrubber and chemical addition systems including the associated tank farm. The panel interfaces with motor starters and SCADA located in the MCC A and B building.

Relocating the odor control panel would require an unacceptable outage and loss of the odor control system. It is recommended that a new odor control panel be installed in a new outdoor location with conduits and conductors roughed in while the existing odor control panel is in operation to allow a phased cutover of pumps and instruments.

7.4 SCADA

The existing PLC in the MCC building appears to have sufficient spare I/O and empty rack slots to accommodate the upgrades. Most existing I/O will become spare from removed loads and reutilized for new loads.

7.5 NFPA 820

The existing headworks area does not entirely meet NFPA 820. Open channels near the headworks and odor control ducting should be classified as Class 1, Division 2. NFPA 820 provides information on the zone boundaries.

The existing pole lights at the headworks would meet NFPA 820 with appropriate conduit seals. All conduits that are new or reworked within the affected classified boundaries will have conduit seals added.

7.6 Equipment Panels

Motor starters for equipment will be installed in the MCCs in lieu of local control panels. Local control panels (e.g. screens, wash press, sluice) for equipment and instruments will be installed under a common shade canopy on the north side of the Chemical Area. The Odor Control Panel will also be located in this area. Fiber optic cable will be installed from the existing MCC A and B building to the new equipment local control panels area. Remote Hand-Off-Auto and Emergency Stop switches will be provided next to each equipment unit.

7.7 Existing Flow Meter Vaults

The existing flow meters for the Solana Beach and Cardiff forcemains are currently installed in below grade and covered vaults which require multiple personnel, special equipment, and a self-issued confined space permit for Confined Space Entry (CSE). To facilitate access to the meters, the vault roofs will be removed, handrail will be installed around the top, and a permanent ladder will be installed. SEJPA will follow appropriate procedures for entry in the future. Flow meter signal transmitter panels will be installed on the handrail, facing north to minimize glare.

SEWRF Preliminary Treatment Upgrades - Preliminary Design Report

7.8 Lighting

Existing lighting will be replaced with LED fixtures. New outdoor lighting will be installed around the new headworks channels and equipment. Additional fixtures will be added to the bottom floor of the Grit and Screenings Building to improve the lighting.

7.9 Recommendations

The following actions are recommended for the electrical systems:

- Intercept existing conduits associated with the removal and addition of equipment and extend to new locations as required.
- Install new odor control panel outdoor to aid in equipment and instrument cutover.
- All conduits that are new or reworked within the affected NFPA 820 classified boundaries will have conduit seals added.
- Install motor starters in motor control centers.
- Install control panels under common shade canopy just north of Chemical Area.
- Install fiber optic cable between MCC building and equipment local control panels
- Install Hand-Off-Auto and Emergency Stop switches at each equipment unit
- Improve access to existing flow meters by removing vault roofs and adding guardrail, ladder, and appurtenances as required
- Replace all existing Headworks lighting with LED fixtures, install new outdoor lighting around new headworks, and improve lighting in bottom floor of the Grit and Screenings Building.

SEWRF Preliminary Treatment Upgrades - Preliminary Design Report

THIS PAGE INTENTIONALLY LEFT BLANK

SEWRF Preliminary Treatment Upgrades - Preliminary Design Report

8 PROJECT IMPLEMENTATION

8.1 Recommended Project

Dudek recommends that the SEWRF Headworks Upgrade Project include the following:

- **Hydraulics and Layout**
 - Modify existing channels to alleviate existing hydraulic constraints
 - Reuse existing channels for emergency overflow/bypass
 - Construct Layout Alternative 2 (3-foot wide channels with fillets, two new screen channels, reuse existing channels for emergency overflow/bypass)
- **Screenings Equipment**
 - Installation of new multi-rake bar screens or step screen with at least one (1) standby unit
 - Installation of a single screenings sluice conveyor with redundant inlet water valves and diverter gates at the discharge
 - Installation of a two (2) wash presses in the existing Grit and Screenings Building
- **Grit Equipment**
 - Have the classifier manufacturer, WEMCO, retrofit the existing classifiers in the field with the new gasketed odor control panels
 - Install odor control ducting for grit classifiers
 - Install a new grit aeration piping fed from the aeration tanks air header to replace the grit aeration blowers
 - Remove the existing grit aeration blowers
 - Rehabilitate the grit chamber concrete coating
 - Replace the grit chamber covers per Section 5.5.
- **Structural**
 - Rehabilitate and recoat all existing inside faces of concrete channels and upper 4-feet of grit chamber
 - Coat all inside faces of new concrete channels
 - Raise channel heights as necessary based on selected layout alternatives; add reinforcement struts as required.
 - Install un-punched aluminum plank grating over new channels
 - Replace existing aluminum Grit Chamber covers
- **Odor Control**
 - Replace exhaust grill on bottom floor of Grit and Screenings Building.
 - Install new odor control recirculation pump and water softener system outside near the existing scrubber.
 - Install new odor control local control panel outdoors under new shade canopy on north side of Chemical Area.
 - Add requirements for temporary odor control scrubber during construction to final specification.

SEWRF Preliminary Treatment Upgrades - Preliminary Design Report

- Do not increase air flowrate of the existing Headworks scrubber
- Add channel covers to Screen Influent Channels
- Add gasketed odor control panels to the new bar screen
- Add gasketed odor control panels to the existing grit classifiers (see Section 4)
- Add foul air duct connections to all screens, classifiers, and sluice
- Add additional duct connections to existing screenings effluent channels, and Grit Chamber inlet and effluent channel
- Add duct connections to new Headworks channel covers
- Add additional intake louvers and exhaust ducting/grills/hoods to Grit and Screenings Building to improve distribution and prevent short-circuiting
- Rebalance foul air ducting to maintain 6 ACPH, or 10% higher flowrates than aeration, in enclosed, unoccupied spaces, and 24 ACPH for Grit and Screenings Building.
- Electrical
 - Intercept existing conduits associated with the removal and addition of equipment and extend to new locations as required.
 - Install new odor control panel outdoor to aid in equipment and instrument cutover
 - All conduits that are new or reworked within the affected NFPA 820 classified boundaries will have conduit seals added.
 - Install motor starters in motor control centers
 - Install control panels under common shade canopy just north of Chemical Area
 - Install fiber optic cable between MCC building and equipment local control panels
 - Install Hand-Off-Auto and Emergency Stop switches at each equipment unit
 - Improve access to existing flow meters by removing vault roofs and adding guardrail, ladders, etc.
 - Replace all existing Headworks lighting with LED fixtures, install new outdoor lighting around new headworks, and improve lighting in bottom floor of the Grit and Screenings Building.

A preliminary mechanical plan and sections of the recommended project is included in Figure 8-1 and Figure 8-2, respectively. A process flow diagram and hydraulic profile of the recommended project is presented in Figure 8-3 and Figure 8-4, respectively.

P:\101.Engineering\San Elijo_JPA\8981 Headworks Rehab and Upgrade\06-Design\CAD\8981.dwg REPORT FIGURES

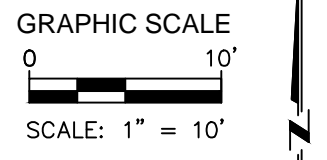
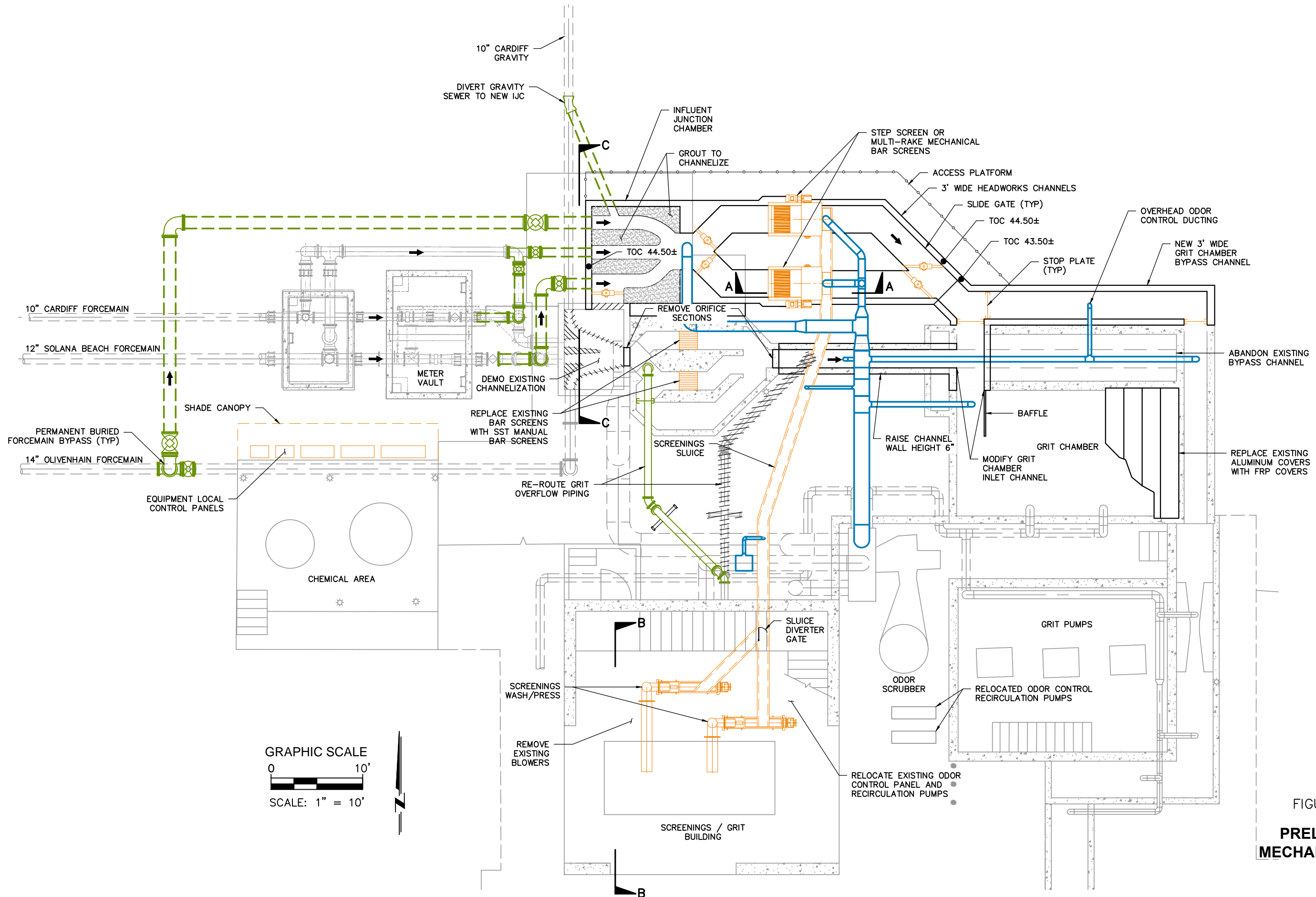
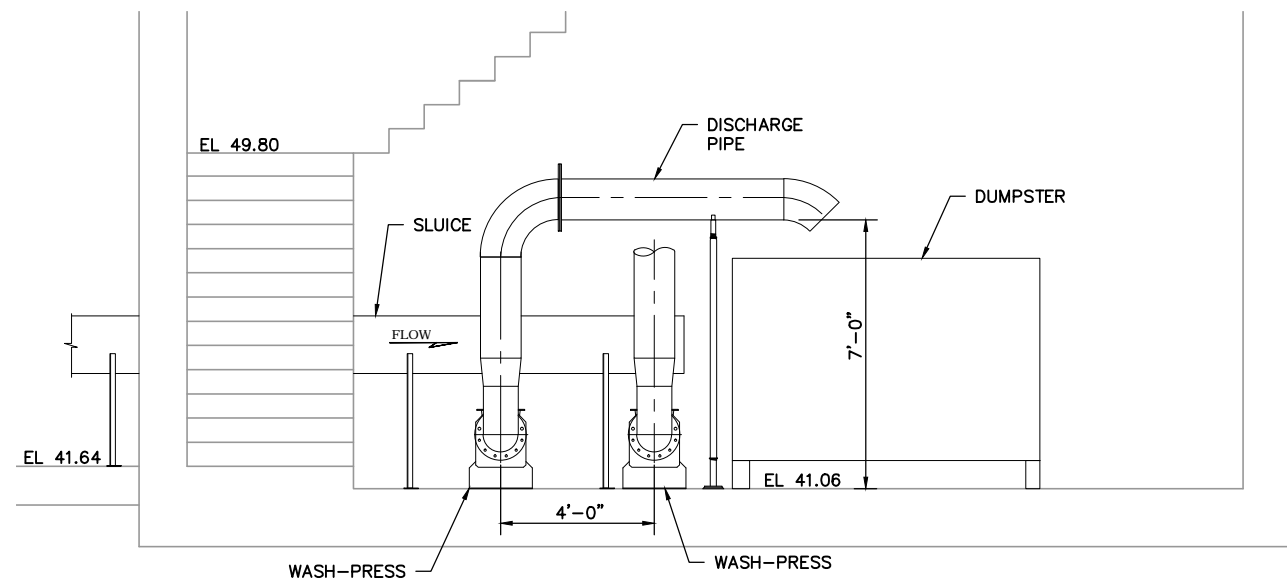

FIGURE 8-1
**PRELIMINARY
 MECHANICAL PLAN**

THIS PAGE INTENTIONALLY LEFT BLANK

P:\101.Engineering\San Elijo_JPA\8981 Headworks Rehab and Upgrade\06-Design\CAD\8981.dwg\REPORT FIGURES



SECTION B-B

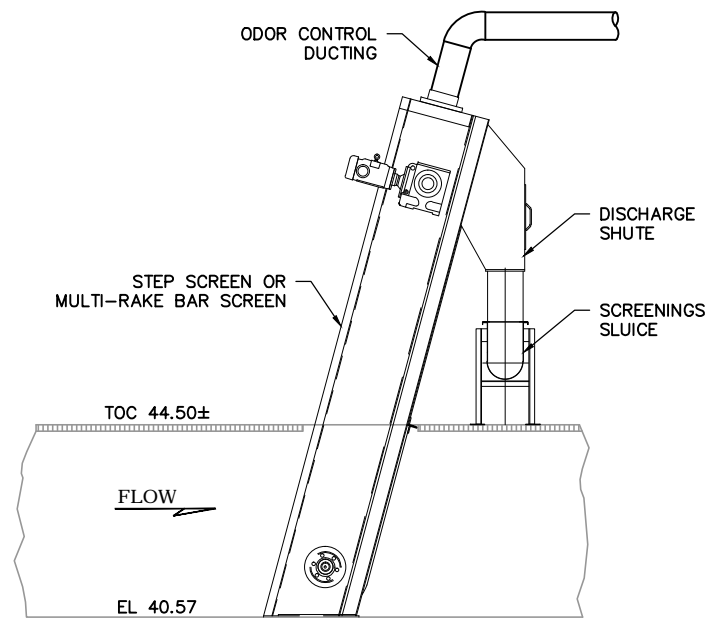

SECTION A-A

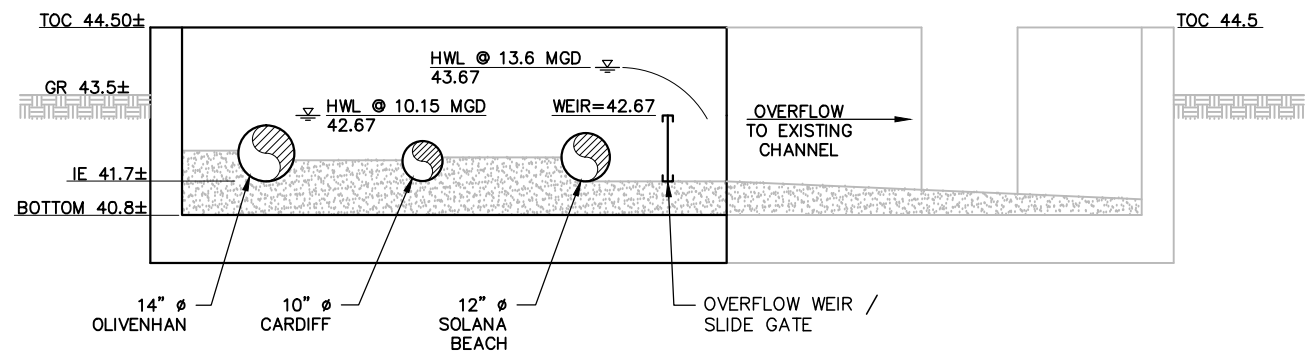

SECTION C-C

FIGURE 8-2
PRELIMINARY
MECHANICAL
SECTIONS

THIS PAGE INTENTIONALLY LEFT BLANK

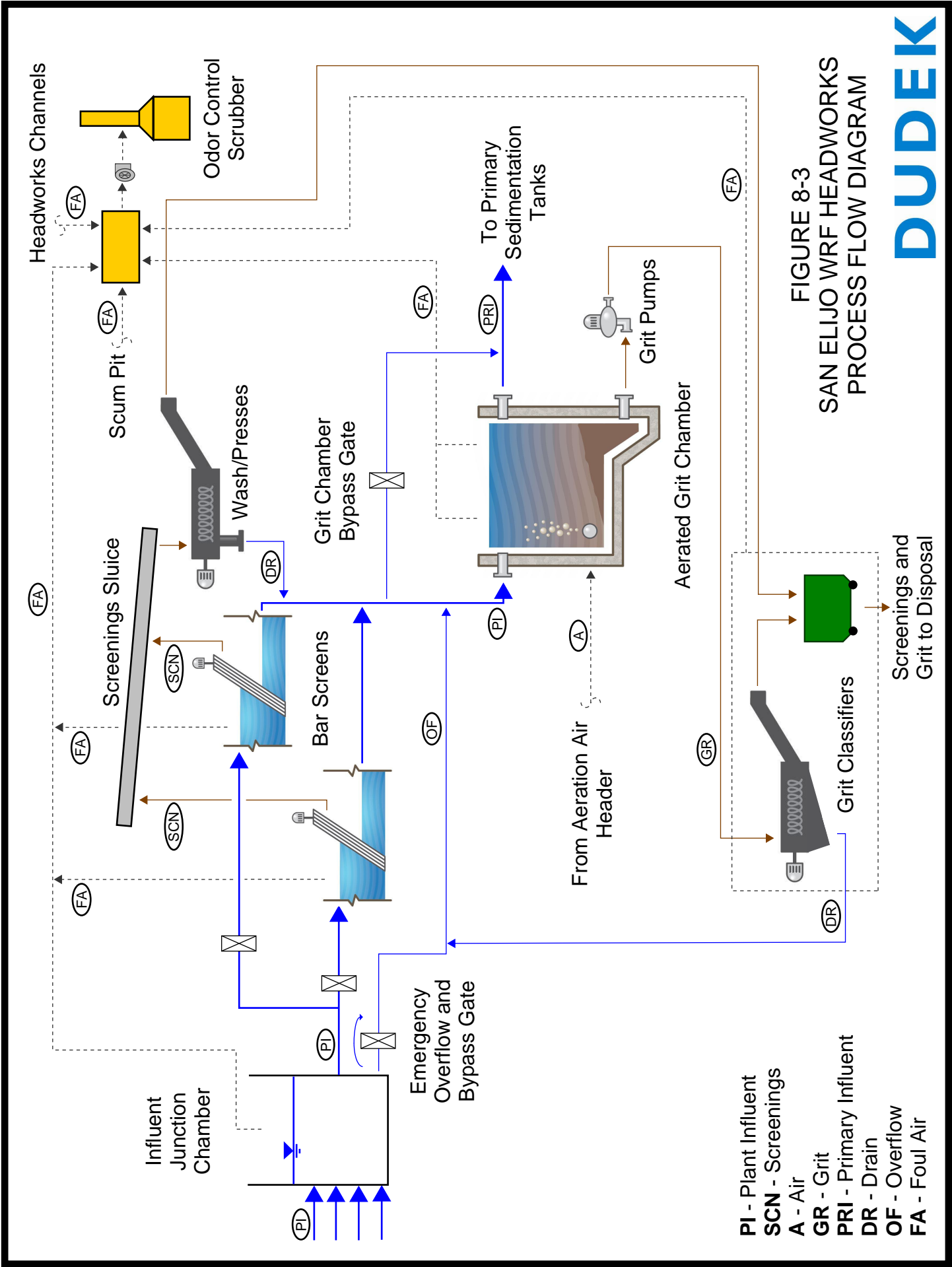

PI - Plant Influent
SCN - Screenings
A - Air
GR - Grit
PRI - Primary Influent
DR - Drain
OF - Overflow
FA - Foul Air

FIGURE 8-3
SAN ELIJO WRF HEADWORKS
PROCESS FLOW DIAGRAM

SEWRF Preliminary Treatment Upgrades - Preliminary Design Report

THIS PAGE INTENTIONALLY LEFT BLANK

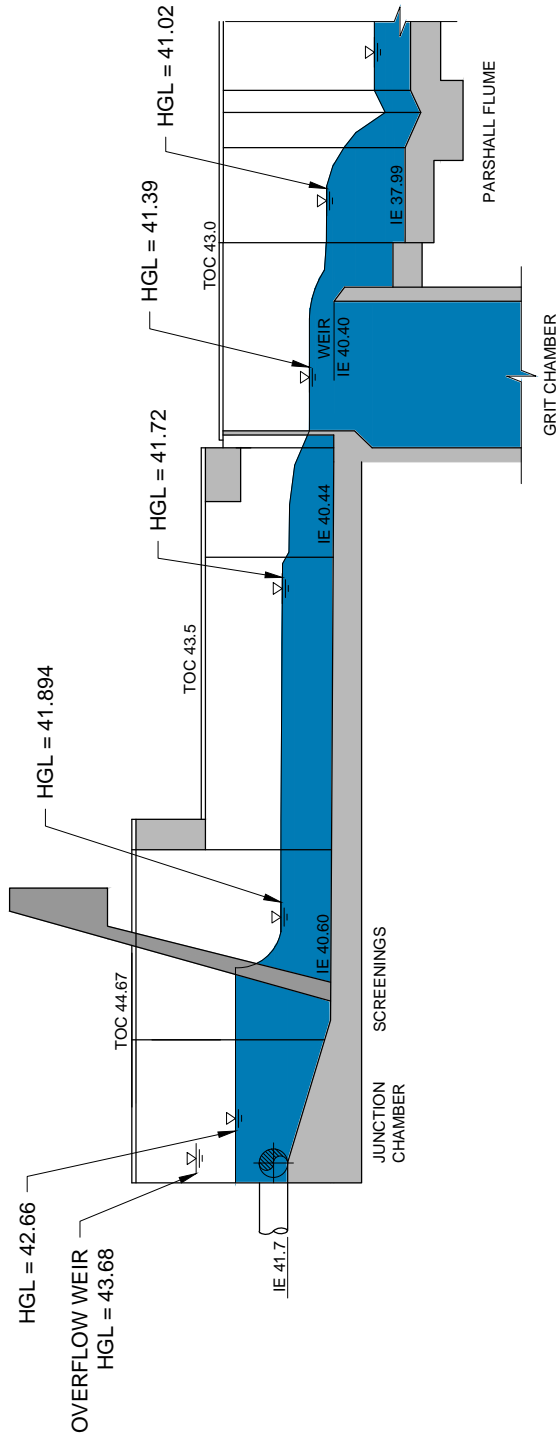

NOTE:
 HYDRAULIC GRADE LINES (HGL) SHOWN FOR PLANT FLOW RATE OF 13.6 MGD, WITH 3.45 MGD OVERFLOWING BYPASS WEIR AND 10.15 MGD FLOWING THROUGH SCREEN

FIGURE 8-4
 HYDRAULIC PROFILE

SEWRF Preliminary Treatment Upgrades - Preliminary Design Report

THIS PAGE INTENTIONALLY LEFT BLANK

SEWRF Preliminary Treatment Upgrades - Preliminary Design Report

8.2 OPCC

The Engineers Opinion of Probable Construction Cost (OPCC) is included as an attachment to this PDR. Contractor overhead and profit is included in each individual line item as a percentage of material or equipment quotes. A project level contingency of 20% was added to the subtotal at this preliminary design phase and will be reduced to 10% during the final design phase as more detailed takeoffs and project cost data is available. This OPCC of phased construction costs does not include soft costs (e.g., design, construction, operating, and management).

Headworks upgrade construction costs are anticipated to be \$2,470,000 which assumes Layout Alternative 2. Detailed opinions of probable construction cost (Layout Alternatives 1 through 5 as described in Section 2) are included in Appendix D.

Other project costs will include engineering work for construction documents; construction management; planning costs; and the SEJPA’s administration and legal costs. The average costs for engineering and construction management are each estimated at 10% of the estimated construction cost. Planning and administration costs are each estimated at 5% of estimated construction cost.

8.3 Project Implementation Schedule

Total construction duration of 12 months after notice to award is anticipated for the Headworks upgrade project. The anticipated project schedule is presented in Table 8-1.

Table 8-1: Anticipated Project Schedule

Task	Date
PDR Completion	October 2015
Final Design Completion	August 2016
Advertisement	September 2016
Bid Opening	November 2016
Construction Notice to Proceed	January 2017
Construction Completion	December 2017
Startup and Testing	January 2018

8.4 Permitting Requirements

8.4.1 CEQA Permitting

Due to the minimal nature of the improvements proposed, the project would fall under a Categorical Exemption as outlined in Section 15302 of the CEQA Guidelines, *Replacement or Reconstruction*. Pursuant to Section 15302(c), the project would include “replacement or

SEWRF Preliminary Treatment Upgrades - Preliminary Design Report

reconstruction of existing structures and facilities where the new structure will be located on the same site as the structure replaced and will have substantially the same purpose and capacity as the structure replaced” (CEQA, 2015). Therefore, pursuant to Section 15300 of the CEQA Guidelines, the project would not have a significant effect on the environment and would be declared to be categorically exempt from the requirement for the preparation of environmental documents (CEQA, 2015).

8.4.2 Stormwater Permitting

For the proposed project, Stormwater Pollution Prevention Plan (SWPPP) permitting will not be required because the construction footprint will be less than one acre. SWPPP permitting is required according to the following description:

Construction activity resulting in a land disturbance of one acre or more, or less than one acre but part of a larger common plan of development or sale must obtain Construction Activities Storm Water General Permit (2009-0009-DWQ Permit). Construction activity includes clearing, grading, excavation, stockpiling, and reconstruction of existing facilities involving removal and replacement. Construction activity does not include routine maintenance such as, maintenance of original line and grade, hydraulic capacity, or original purpose of the facility.

In addition, it is not expected the project will require a Water Quality Management Plan (WQMP) for design of permanent Best Management Practices (BMP's) regarding runoff pollution control. Standard source control BMP's for a construction site such as sediment control, fugitive dust control, and general water quality protection would be required and enforced however.

APPENDIX A

Site Observation Photos

SEWRF Preliminary Treatment Upgrades - Preliminary Design Report

THIS PAGE INTENTIONALLY LEFT BLANK

Screenings Equipment



Screenings Area



Screenings Wash/Press



Mechanical Bar Screen



Manual Bar Screen

Grit Handling Equipment



Grit Pump



Grit Pump



Grit Blower



Grit Blower



Grit Classifier



Grit Cyclone

Structural



Influent Junction Chamber



Screenings Influent Channel



Grit Influent Channel



Grit Influent Channel



Grit Influent Channel



Grit Influent Channel



Grit Chamber



Grit Chamber Covers



Grit Effluent Weir and Channel



Grit Effluent Channel



Grit Effluent Channel



Grit Effluent Channel



Parshall Flume



Grit Effluent Channel

Odor Control Equipment



Odor Control Fan



Odor Control Scrubber Tower



Chemical Recirculation Pump



Chemical Piping and Water Softening Tanks



Duct Plenum



Odor Control Duct Corrosion

APPENDIX B
Kickoff Meeting Presentation

SEWRF Preliminary Treatment Upgrades - Preliminary Design Report

THIS PAGE INTENTIONALLY LEFT BLANK

San Elijo Water Reclamation Facility

Headworks Upgrades and Rehab Project



Kickoff Meeting

June 3, 2015

Prepared for:

San Elijo Joint Powers Authority

2695 Manchester Avenue

Cardiff by the Sea, California 92007



Meeting Outline

- **Introductions**
- **Project Purpose/Objectives**
- **Project Approach**
- **Data Requests**
- **Administrative/Contractual/Procedural Items**
- **Schedule**
- **Other Discussion Items**
- **Action Items**

Project Purpose/Objectives

- **Relieve Hydraulic Constraints**
- **Increase Reliability and Redundancy for Equipment and Structures**
- **Optimize Screenings Removal Process**
- **Improve Access at Headworks and Minimize O&M Intensity for Screenings Handling**
- **Observe Operational Constraints and Constructability**
- **Other Headworks Objectives/Issues to be resolved**

Level of Service

- Balance objectives
 - Headloss vs. Screening Capture
 - Screening capture vs. Screenings Handling

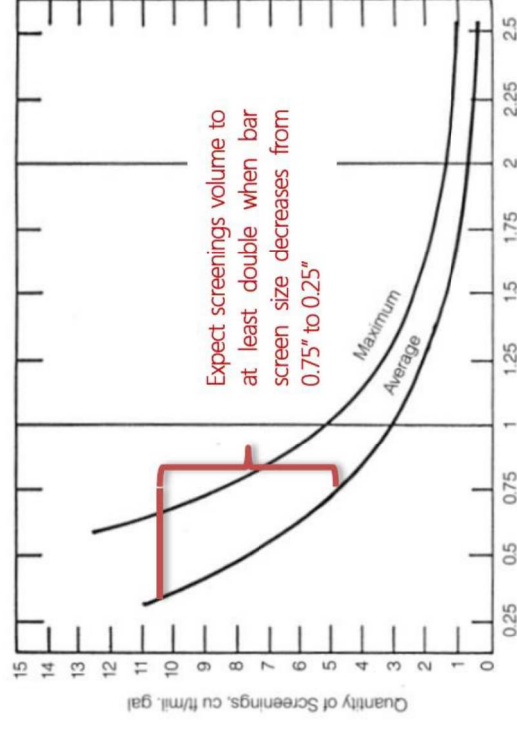
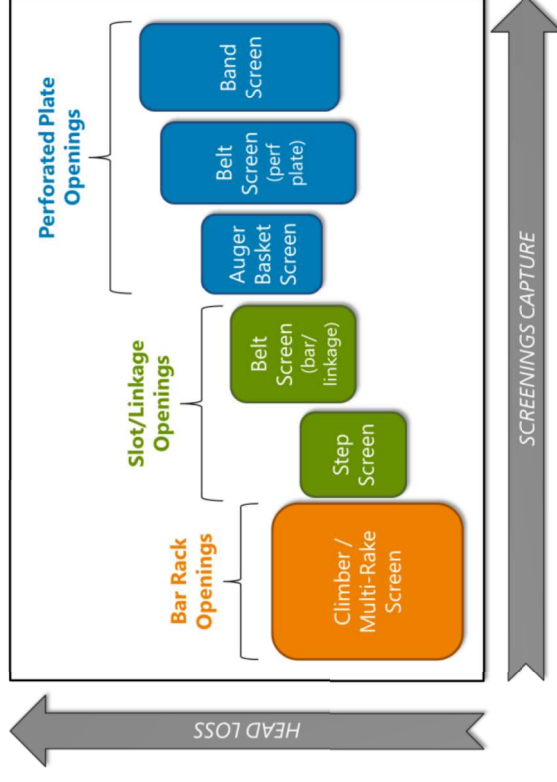

Screen Types

- **Bar Screens**
 - Reciprocating Rake Bar Screen
 - Multi-Rake (Chain Driven) Bar Screen
 - Multi-Rake (Catenary/Chain Hybrid) Bar Screen
- **Belt Screens**
 - Continuous Belt (bar/slots)
 - Continuous Belt (perforated Plate)
 - Band Screen
- **Step Screen**
- **Basket Screens**
 - Auger Basket Screen
 - Rotating Basket/Drum Screen

Features Available to all Screen Types

- **At least 1/4" (6mm) openings available**
- **Odor Control Covers**
- **316 Stainless Steel Construction**
- **Field Tested – Reputable Manufacturers**

Characteristics to Consider

- **Equipment Dimensions/Layout**
- **Openings Type/Sizes**
- **Screenings Capture**
- **Solids Carryover**
- **Headloss**
- **Cleaning Speed**
- **Wear Parts and Submerged Parts**
- **Daily/Long Term Maintenance**
- **Jamming Resistance and Durability**
- **Cost**
- **Operator Preference & JPA's Objectives**

Bar Screens

- **Rake-cleaned bar rack**
 - Bar spacing: $\frac{1}{4}$ " (6mm) to 2"
 - Installed at ~ 75 deg
 - Solids scraped off rakes
- **Lowest screenings capture ratio**
- **Low headloss**



Bar Screen - Reciprocating Rake (Climber)

- Existing type at SEWRF
- Key Features
 - Narrow frame width = less headloss
 - Slower cleaning speed
 - Submerged parts: None
 - Wear parts: None
 - “Carryover” Pathway: None
- Components
 - Drive Motor and Cogwheel Mech
- Manufacturers
 - Vulcan, Infilco-Degremont

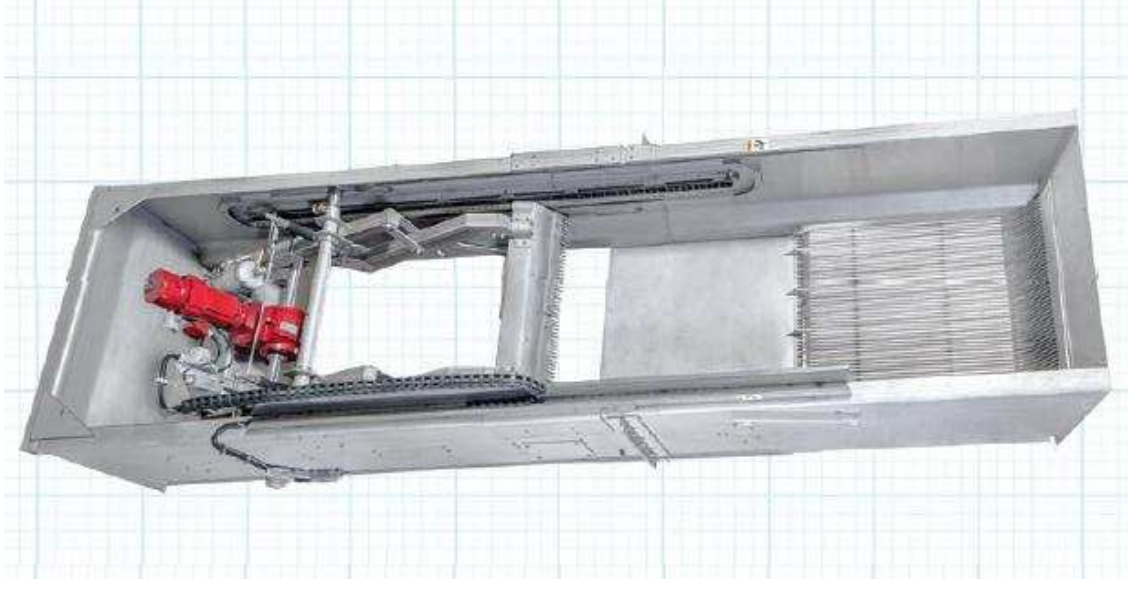

Bar Screen - Multi-Rake (Chain Driven)

- **Key Features**
 - Susceptible to jamming
 - Submerged parts: Chain
 - Wear parts: None
 - “Carryover” Pathway: None
- **Components**
 - Drive Motor and Chain
- **Manufacturers**
 - Vulcan, WesTech

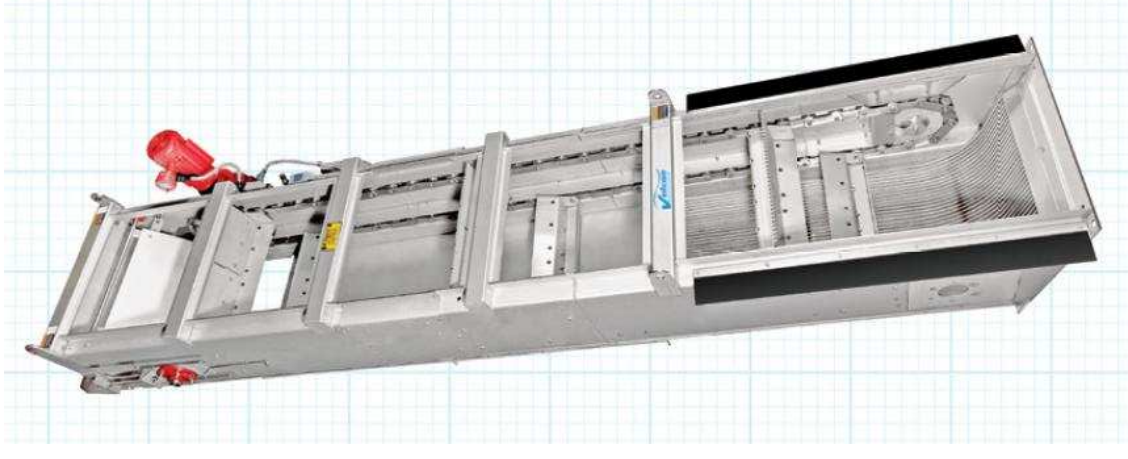

Bar Screen - Multi-Rake (Catenary Hybrid)

- **Key Features**
 - Linkage system flexes over large objects
 - Submerged parts: linkage system
 - Wear parts: None
 - “Carryover” Pathway: None
- **Components**
 - Drive Motor and Linkage
- **Manufacturers**
 - Duperon

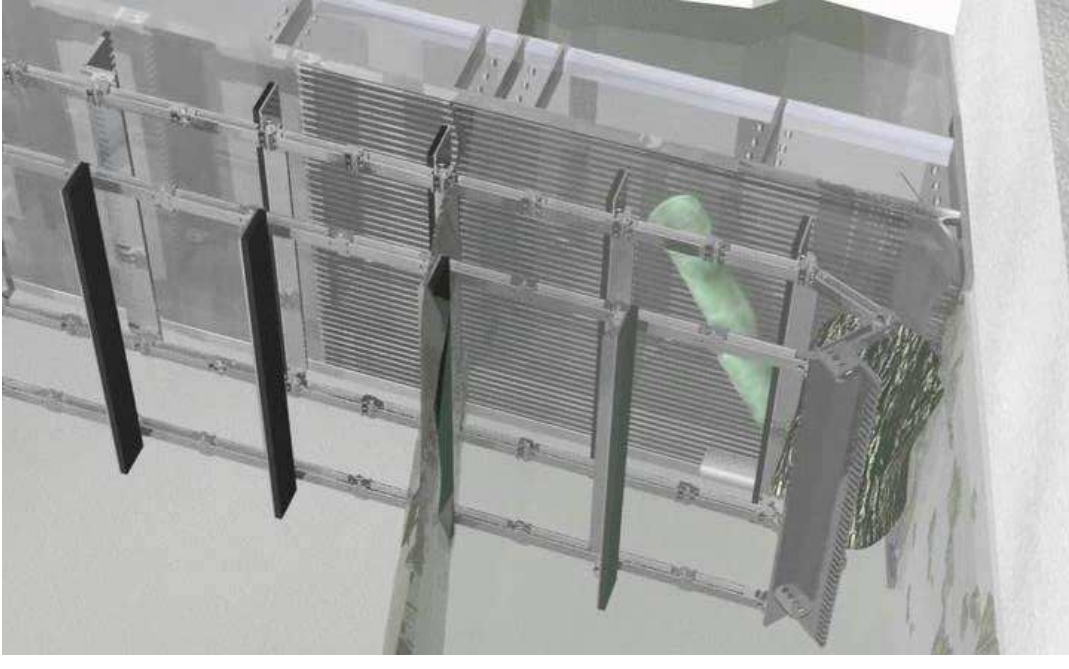

Belt Screens

- **Continuous belt/linkage of filter panels**
 - Perforated Plate or Bar/Slots
 - Openings: 1mm to 6 mm (1/4") openings (up to 1" for bar/slots)
 - Less prone to jamming
 - Seals on side & bottom
 - Spray and/or brush to remove solids
- **High Screenings Capture Ratio**
- **Expensive**



Belt Screen - Continuous Belt (bar/slots)

- **Key Features**
 - Installed perpendicular to flow
 - Submerged parts: linkage system
 - Wear parts: Brush and Seals
 - “Carryover” pathway:
 - Side & bottom seals,
 - Back returned belt (brush/spray clean)
- **Components**
 - Drive Motor, Belt/Linkage, Rotating Brush, Spray Valves
- **Manufacturers**
 - Parkson, Andritz, WesTech

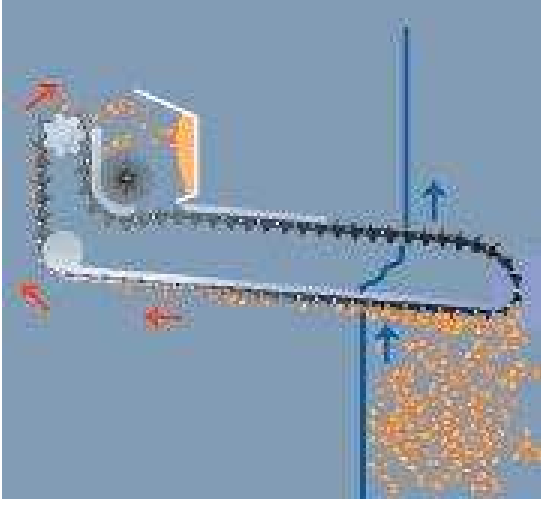

Belt Screen - Continuous Belt (Perf Plate)

- **Key Features**
 - Installed perpendicular to flow
 - Submerged parts: linkage system
 - Wear parts: Brush and Seals
 - “Carryover” pathway:
 - Side & bottom seals,
 - Back returned belt (brush/spray clean)
- **Components**
 - Drive Motor, Belt/Linkage, Rotating Brush, Spray Valves
- **Manufacturers**
 - Parkson, JWC



Belt Screen - Band Screen

- **Key Features**
 - High headloss
 - Installed parallel to flow
 - Inside-out flow path
 - Submerged parts: linkage system
 - Wear parts: Seals
 - “Carryover” pathway: Side seals
- **Components**
 - Drive Motor, Belt/Linkage, Spray Valves
- **Manufacturers**
 - Ovivo (Bracket Green), JWC



Step Screen

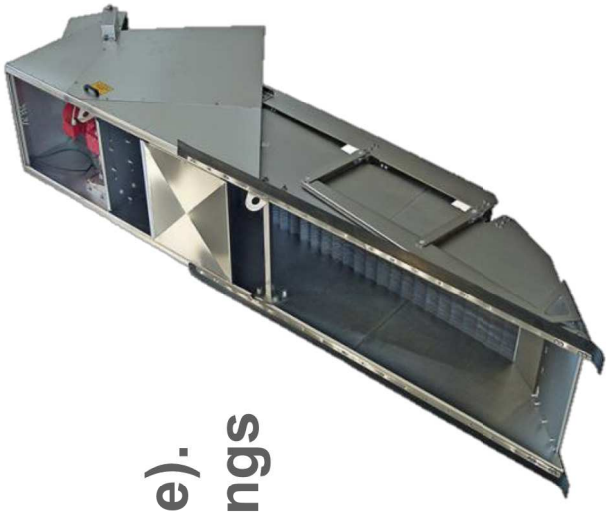

- **Key Features**
 - 2 sets of thin vert plates (1 fixed, 1 moveable).
 - Moveable plate rotates to slowly lift screenings
 - Installed at ~ 50 deg
 - 1mm to 6mm (1/4") openings
 - Screen blinds to improve capture
 - Submerged parts: linkage arm
 - Wear parts: None
 - “Carryover” pathway: None
- **Components**
 - Drive Motor, Linkage Arm
- **Manufacturers**
 - Huber, WesTech

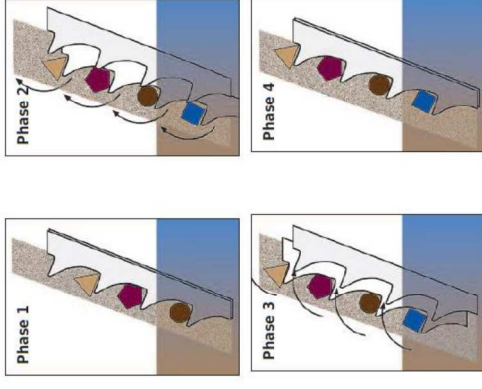

Basket Screens

- **Perforate Plate Basket**
- **Inclined at ~ 35 deg**
- **Auger transports solids**
- **Integral compactor
(Compaction Zone)**
- **Optional Washing System**
 - **Wash Water Valve Assembly**
- **1mm to 6mm (1/4")
openings**



Basket Screen - Auger Basket Screen

- **Key Features**
 - Screw auger scrapes screenings off basket
 - Submerged parts: none
 - Wear parts: Brushes on auger
 - “Carryover” pathway: None
- **Components**
 - Drive Motor, Auger, Wash Water Valves
- **Manufacturers**
 - Huber, WesTech



Basket Screen - Rotating Basket Screen

- May be too large for channels
- Key Features
 - Basket rotates and drops screenings into auger trough
 - Spray nozzles to remove screenings
 - Submerged parts: Center Bearing
 - Wear parts: Perimeter Seals
 - “Carryover” pathway: Seal
- Components
 - Drive Motor, Rotating Basket Drive, Wash & Spray Valves
- Manufacturers
 - Huber, Lakeside



Screen Selection

- **Identify “Fatal Flaws”**
- **Physical Fit**
- **Hydraulic Fit**
- **Meet JPA’s objectives**
- **Scoring Matrix**
 - **Weighted Categories**
 - **Operations’ Preferences**

Screenings Conveyance

- Belt Conveyors
- Screw Conveyors
- Sluice



Screenings Washer/Compactor

- **Critical Features**
 - 316 SST Construction (alloy steel shaft)
 - Separate Washing and Dewatering zones
 - Forward-Reverse Cycles
- **Manufacturer to match Screen**
- **Optional grinder on inlet**
- **Sized to handle screening load**

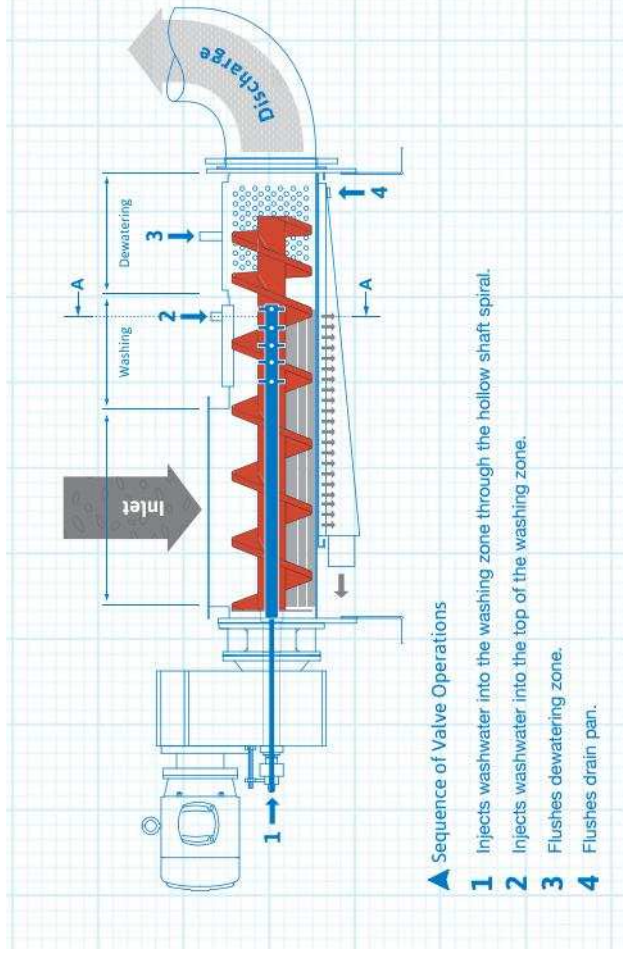

Hydraulics

- Raise channel walls
- Additional channel
- Through-Screen Velocity

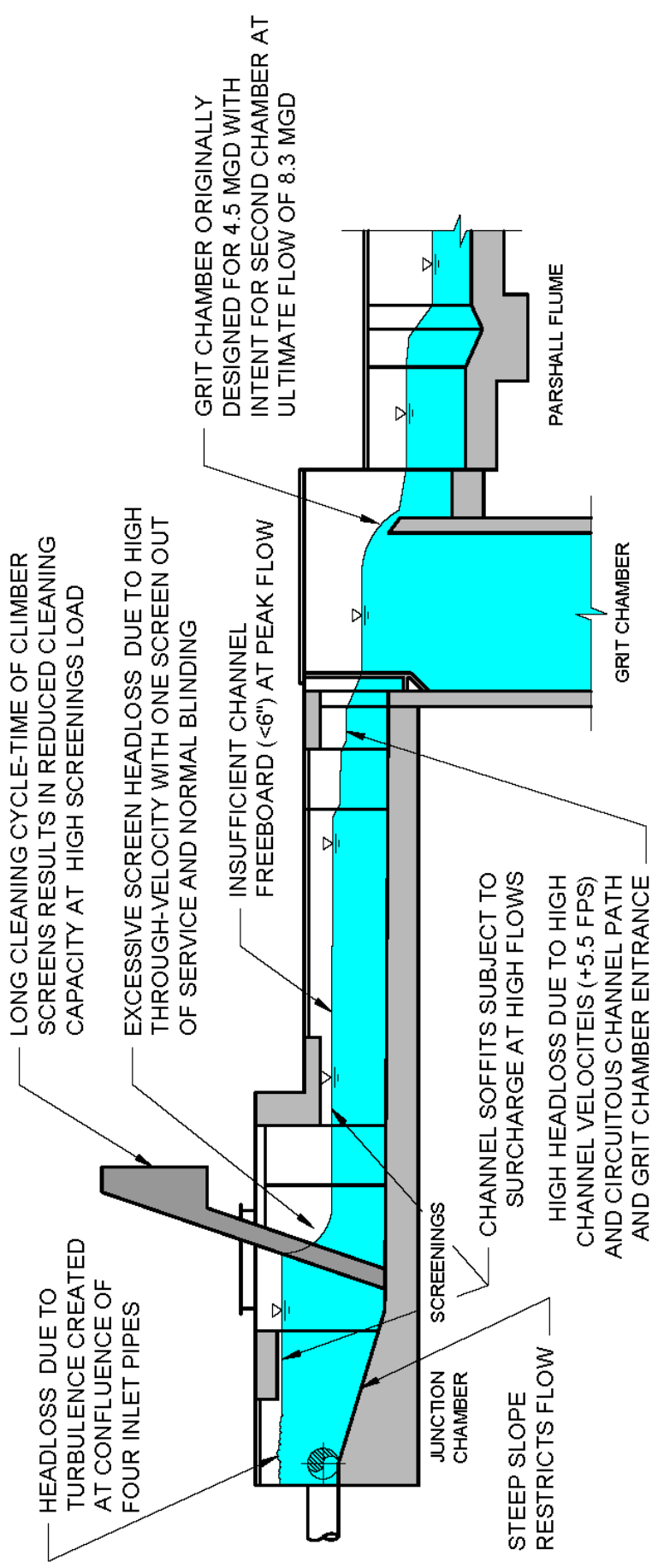

Screenings Handling Strategy

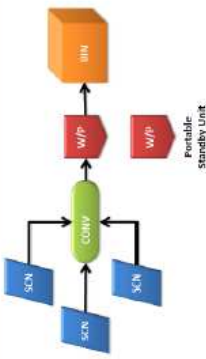
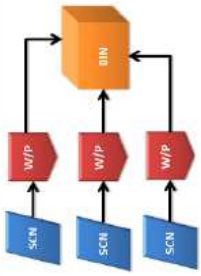
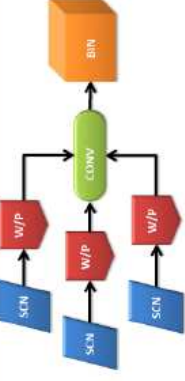
Configuration #1	Configuration #2	Configuration #3
 <p>SCN: Discharge to conveyor CONV: Conveying raw screenings with:</p> <ul style="list-style-type: none"> Belt Conveyor, Shaftless Screw Conveyor, Sluice <p>W/P: Single Duty Unit – portable w/ standby unit</p>	 <p>SCN: Discharge to dedicated W/P CONV: None W/P: Dedicated Unit to each Screen</p>	 <p>SCN: Discharge to dedicated W/P CONV: Convey dewatered screenings with:</p> <ul style="list-style-type: none"> Belt Conveyor <p>W/P: Dedicated Unit to each Screen</p>
Screenings Handling Strategy		
Redundancy		
<p>SCN: 50% - 2 Duty + 1 Standby CONV: None – Use of Sluice mitigates Risk of mechanical failure mode W/P: 100% - Portable unit minimizes conveyor complexity and installed equipment costs</p>	<p>SCN & W/P: 25% - 2 Duty + 1 Standby, however, each SCN & W/P acts as a single process unit with two failure points CONV: n/a</p>	<p>SCN & W/P: 25% - 2 Duty + 1 Standby, however, each SCN & W/P acts as a single process unit with two failure points CONV: None – Limited to belt conveyor which governs failure risk</p>
Conclusion		
<p>Configuration maximizes redundancy while minimizing installation costs. Use of sluice affords flexibility in routing raw screenings to ease layouts. Duede designed the Corona WRF2 headworks in this configuration, accommodating spatial constraints of existing structure; sluice with redundant flushing system alleviates risk of system failure due to conveyor downtime.</p>	<p>Configuration alleviates conveyor equipment in exchange for additional installed equipment. Duede designed the Corona WRF1 headworks in this configuration, dictated by spatial constraints of existing structure.</p>	<p>Configuration requires conveyance of dewatered screenings which limits to belt conveyor. This configuration is not common.</p>

Layout - Alternate No. 1

Outdoor screenings storage

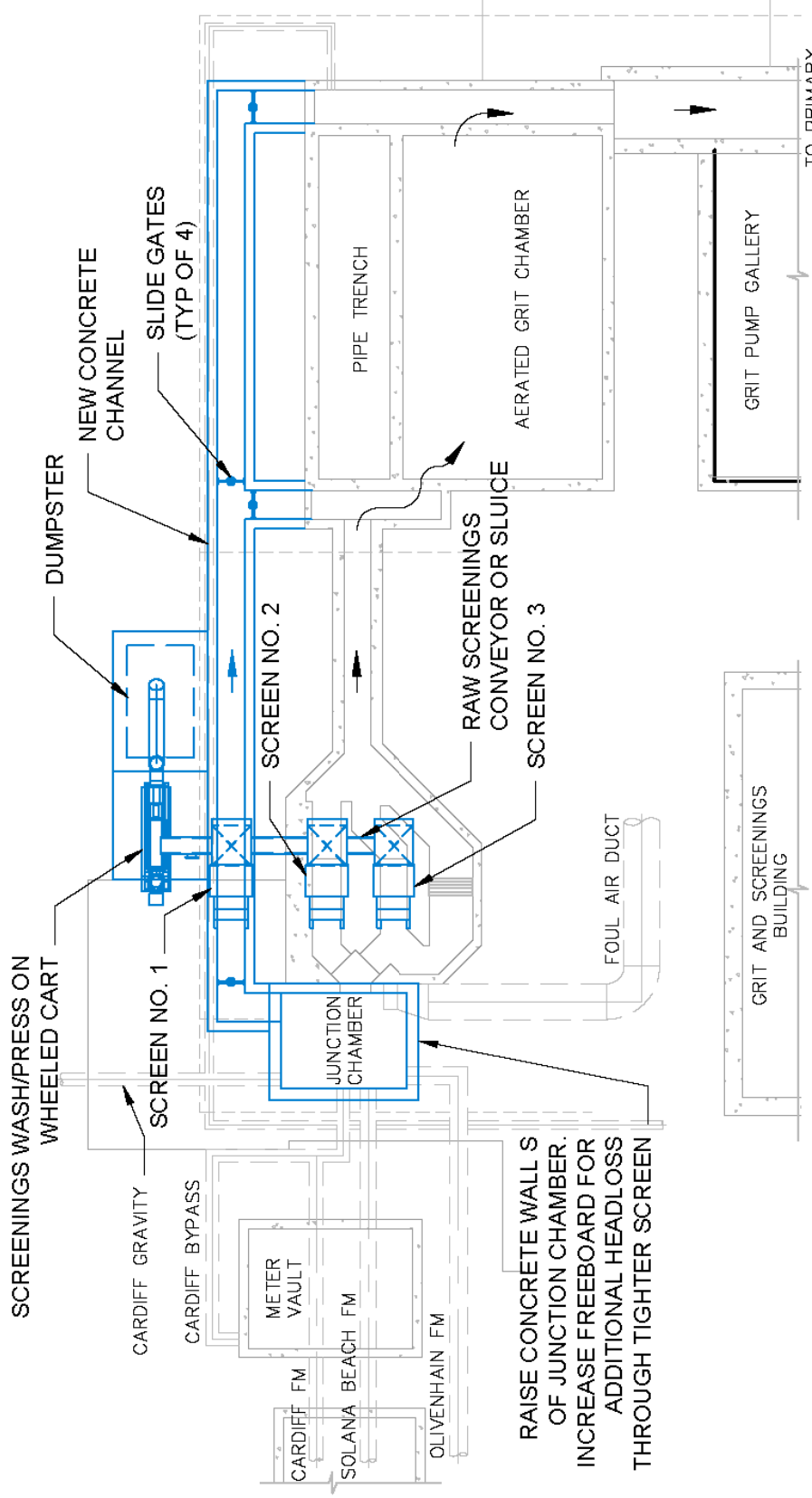

Layout - Alternate No. 2

Indoors screenings storage

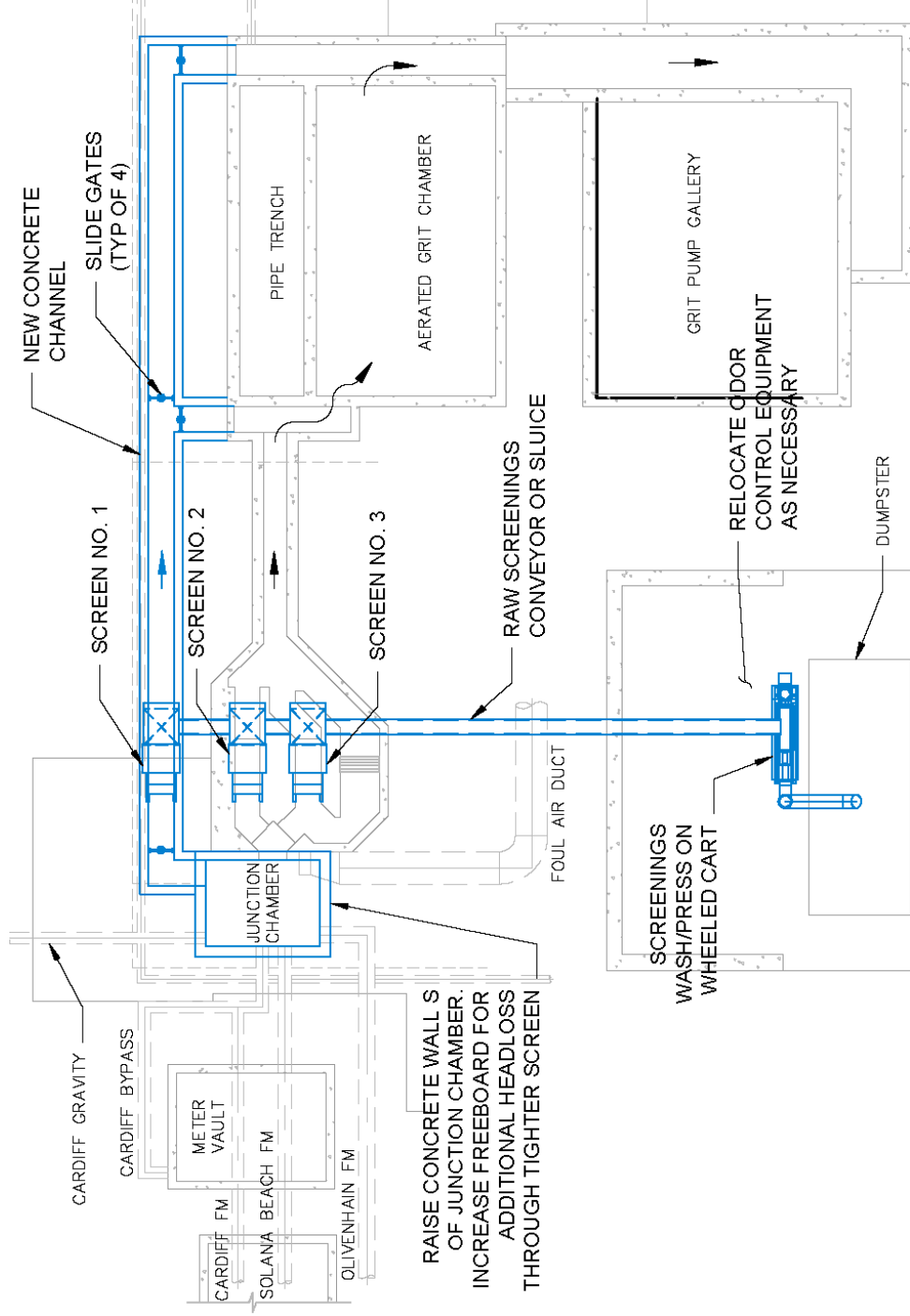

Immediate Next Steps/Schedule

- Info Requests
- Site Visit/Field Measurements
- Determine LOS Objectives
- Screen Equipment Comparison
- Determine Equipment Configuration
- Hydraulics

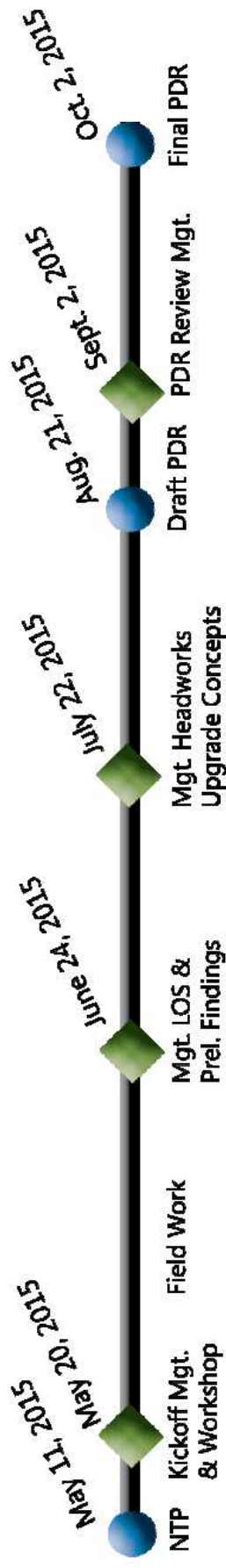

INTENTIONALLY LEFT BLANK

APPENDIX C

Screenings Equipment Vendor Brochures

SEWRF Preliminary Treatment Upgrades - Preliminary Design Report

THIS PAGE INTENTIONALLY LEFT BLANK



Model VMR Multi-Rake Screen

Product Information Guide



Find more product information at:
vulcanindustries.com

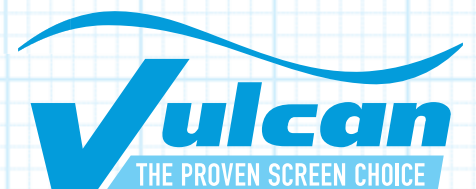



Model VMR Multi-Rake Screen

Chain Take-Up Mechanism

Wiper Mechanism

Internal to screen frame with no brushes or water required.

Stainless Steel Side Frame

Full Frame (as shown), and Spliced Frame (for installation in existing buildings) are available. Standard side frames are formed from 1/4" thick stainless steel plate with four engineered bends for rigidity creating a side frame width of 28" - the strongest frames in the industry.

Dead Plate

Rake Heads

Multiple, large-capacity rake heads with deep tooth penetration and positive engagement of the bar rack.

Choice of Rectangular or Trapezoidal Bar Rack

Bar spacing from 1/4" to 3"+

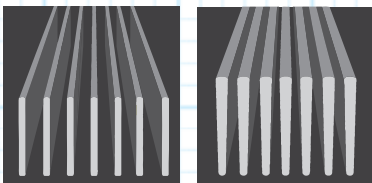

Sized For Your Project

Channel widths from 18 inches to 8 feet, and depths to over 50 feet.

Upper Stainless Steel Drive Sprockets

Drive Options

TEFC and explosion-proof motors available with variable frequency drive (VFD) for soft start and flexible operating speed control.

Stainless Steel Chain Guides

Drive Chains

Heavy-duty stainless steel roller chains.

Lower Engagement System

With choice of guide rail bearings or sprockets.

Lower Curved Bar Rack Bars

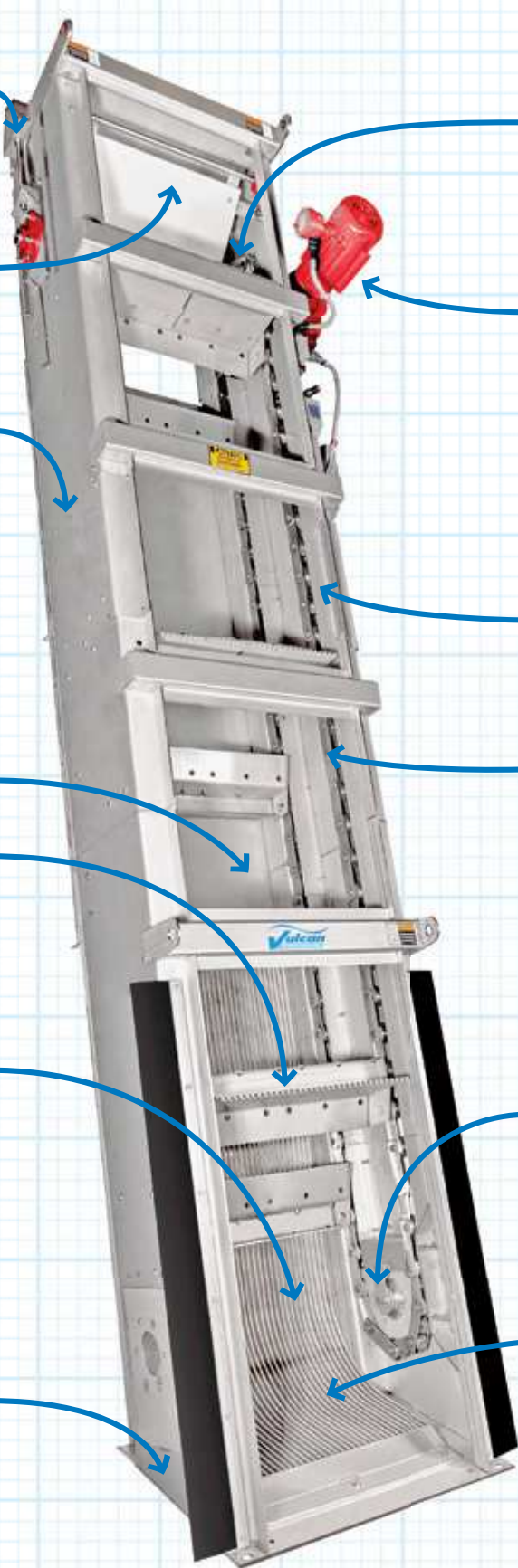

Engineered for Capacity, Known for Reliability

Since 1978, Vulcan has been a leader in manufacturing quality wastewater equipment. The **VMR Multi-Rake Screen** continues this tradition of excellence, incorporating many of the same features found in our Mensch Severe Duty™ Bar Screen. Coupling these tried and true features with Vulcan's own UL approved fully automatic and multiple speed controls produces quick and efficient screenings removal.

Designed for use in high screenings volume applications, the VMR Multi-Rake Screen can efficiently remove large amounts of screenings with continuous operation. The versatility of the VMR Multi-Rake Screen makes it ideal for special applications of extreme channel depth and severe screen blinding. Heavy duty components used in the VMR Multi-Rake Screen ensure a long and productive service life even under the most severe conditions.

The VMR Multi-Rake screen is an automatic, self-cleaning mechanical bar screen designed for tough primary and secondary screening applications.

The VMR Multi-Rake Screen can be customized for new construction as well as existing channels.

Electrical Controls

Each control panel we provide is designed and manufactured by highly skilled technicians in our own electrical facility to meet the specifications for the particular project. Our panels are UL Listed and can meet UL 508A or UL 698A standards. Prior to shipment, each panel is fully assembled and tested with the equipment. Panels can be installed as free standing, wall mounted or screen mounted. Control system design can include a variety of relay or programmable logic devices to interact with today's SCADA and HMI systems. Our standard control package includes timers with ultrasonic differential level control for starting and stopping the screen. Variable Frequency Drives (VFD) provide soft motor starts and a wide range of operating speeds to accommodate each particular application. Motor current is monitored to prevent damage to the screen drive system if something were to lodge into the bar rack. A reversing feature allows back cleaning of the bar rack to dislodge the object and then reverses again to continue screening.

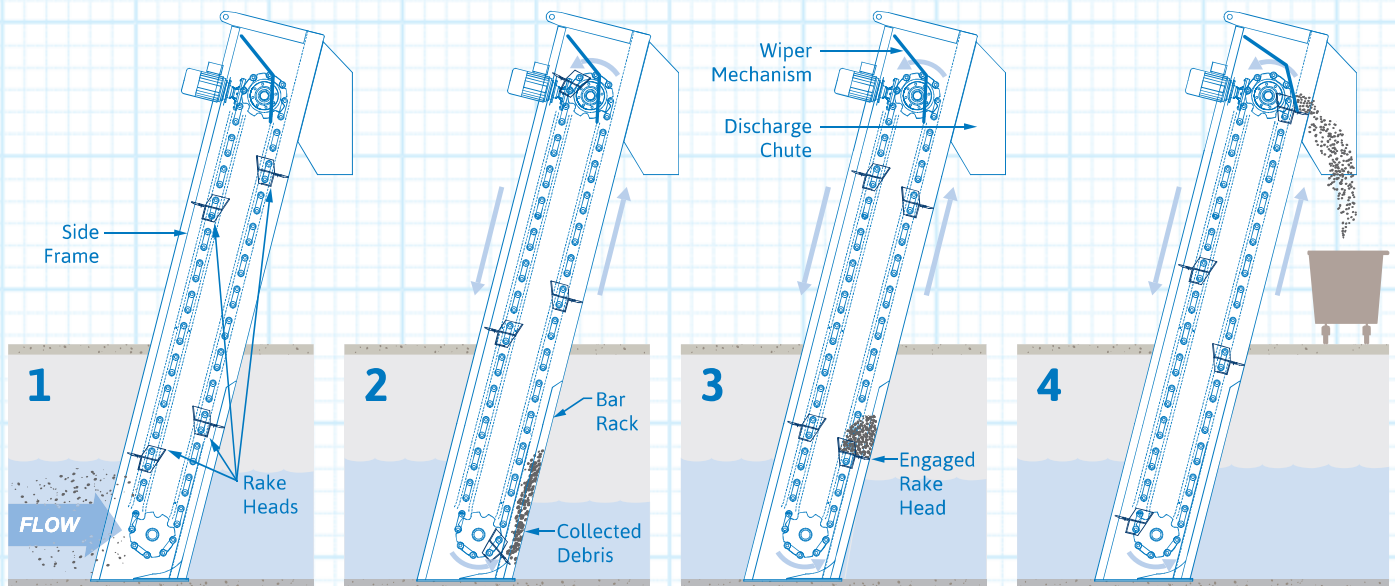

▲ Sequence of Operations

- 1** The bar rack begins to collect screenings while the bar screen is in the idle position.
- 2** As screenings collect and the bar rack blinds, the upstream water level rises which initiates a cleaning cycle.
- 3** One of the multiple rakes engages the bar rack, clearing up the debris and transporting it up the dead plate toward the discharge point.
- 4** When the rake reaches the discharge point, a wiper assembly cleans the rake and directs the screenings to a receiving device (i.e. conveyor, screenings press, dumpster).



Model VMR Multi-Rake Screen



▲ Option 1

Heavy-duty stainless steel chain and lower guide rail engagement system



▲ Option 2

Heavy-duty stainless steel chain and lower sprocket engagement system



▲ Lower Curved Bar Rack

Find more product information at:
vulcanindustries.com

212 S. Kirlin Street
Missouri Valley, Iowa 51555 USA
712-642-2755 Fax 712-642-4256





Model ESR Stair Screen

Product Information Guide

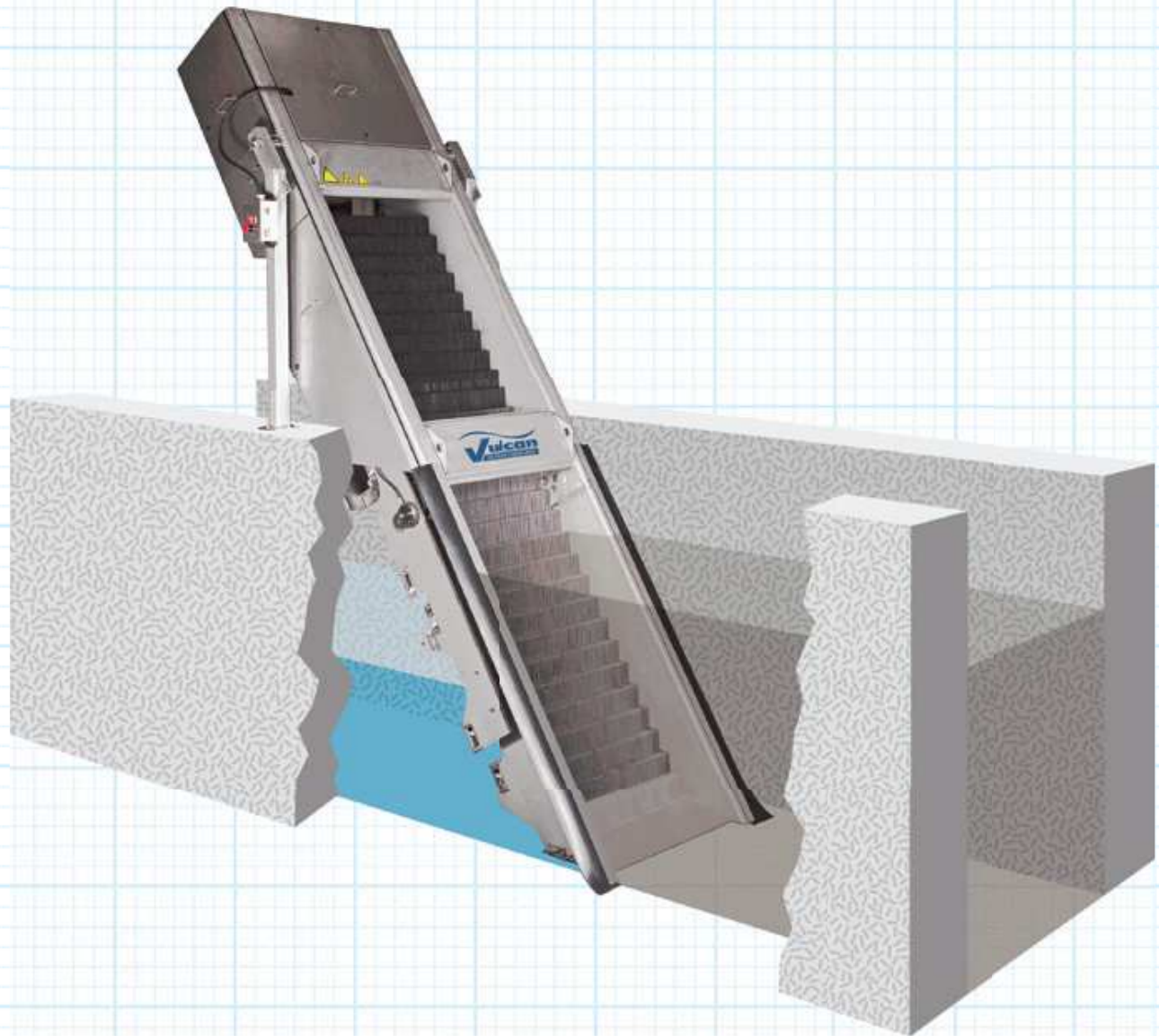

Find more product information at:
vulcanindustries.com

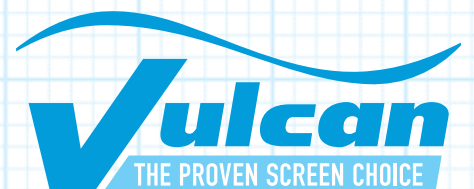



Model ESR Stair Screen

The **Model ESR Stair Screen** is an automatic, self cleaning, fine screen for primary, secondary or sludge screening in municipal and industrial sewage treatment installations. The screens are also ideal for industrial applications such as slaughterhouses, tanneries, breweries, and paper plants. The design of the Model ESR Stair Screen allows for easy installation in new and existing facilities without channel modification. With a maximum setting angle of 57°, the Model ESR Stair Screen has a compact overall footprint.

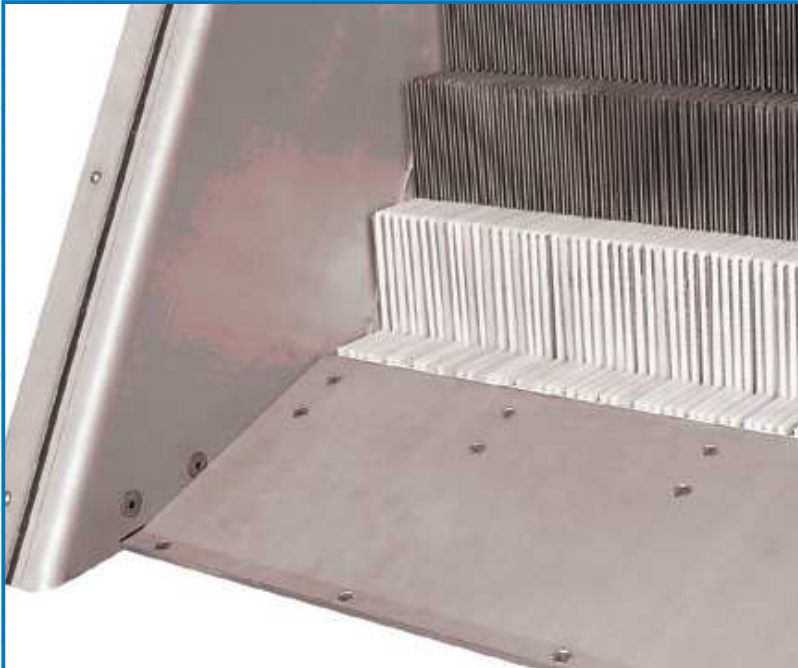

The low profile bottom step is accompanied by a removable diverter plate that extends from the upstream side of the flush bottom base plate to the bottom row of steps. This helps prevent grit and heavy debris from accumulating in front of or under the lamellas. Note the wide plastic sleeves along the bottom row of steps. These sleeves are mounted on the fixed lamellas and they prevent metal-to-metal contact between the movable and fixed lamellas while they maintain the specified bar spacing during operation.

Construction

The side frames of the Model ESR Stair Screen are constructed of formed stainless steel plate having a thickness of 0.24" (6 mm). The screening elements (aka lamellas) in the screening area are stainless steel. The lamellas in the transport area can be stainless steel or a corrosion resistant, UV stabilized synthetic material, depending on the overall height of the screen. The drive system consists of a gear reducer, motor, and a dual chain transmission system with automatic chain tensioning devices. To prevent corrosion, ease maintenance and ensure years of reliable service, the drive system is located completely above the maximum water level, and the gear reducer and motor are encapsulated away from the corrosive atmosphere of the channel. All moving parts of the drive system are protected by removable enclosure panels. The screen enclosure above the channel are equipped with removable panels to provide safe operation and reduce odor.



Post-Screening Devices

In addition to primary screening devices, Vulcan Industries offers a wide array of post-screening and dewatering devices. **The Model EWP Washing Press** and **Model ESP Screw Press** provide dewatering and transport for screenings. Connect multiple screening devices to a single post-screening dewatering and compacting device with a conveyor from Vulcan Industries. To assemble the most cost effective and efficient array of screening and post-screening devices, please contact your Vulcan Industries representative.

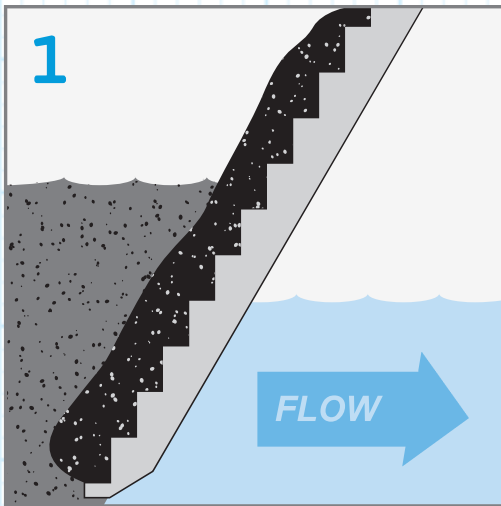

Sequence of Operations

The Model ESR Stair Screen operates on a system of alternating fixed and movable stair-shaped screening elements, or lamellas that extend over the entire screening surface. The nominal space between the screening elements is variable between 1/4" and 1/32". Typical sizes include 6 mm and 3 mm openings . Please contact Vulcan if a different bar spacing is required.

Debris from the flow stream collects on the screening surface to form a mat. This mat acts as a filter to remove particles that would otherwise pass between the lamellas. Typically a thick screenings mat can be formed due to the low headloss characteristics of this type of screen.

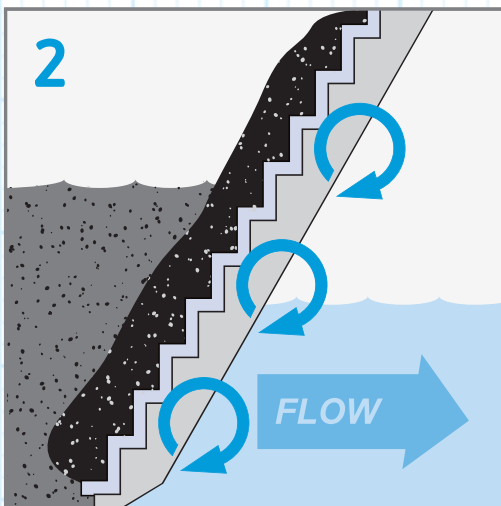

When the differential or high level reaches a predetermined level, the movable lamellas are activated. The movable lamellas rotate upward, lifting the debris to the next highest level of fixed lamellas, and then rotate back to their original position. The drive system provides a positive mechanical action throughout the complete rotation of the movable lamellas. This enables the unit to drive through any debris that may accumulate under the screening surface.

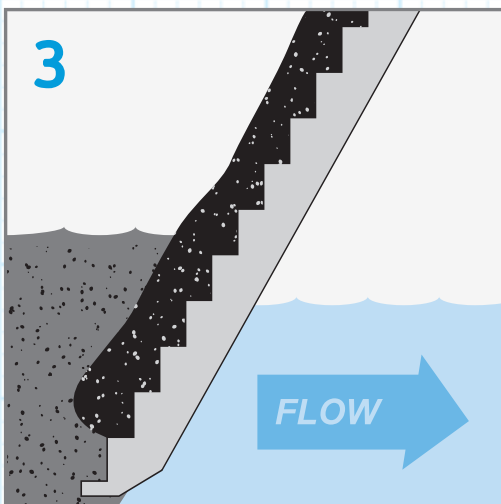

The lamellas move the debris from the screening area in the channel to a transport area above the operating floor. The intermittent and slow progress from channel to discharge allows the debris to shed excess water while suspended on the fixed lamellas. Once the debris reaches the top step it is discharged to a conveyor, post-screening device or suitable container. The rotation of the movable lamellas mechanically forces debris off of the screen at the point of discharge without the need for brushes or spray systems.



Model ESR Stair Screen

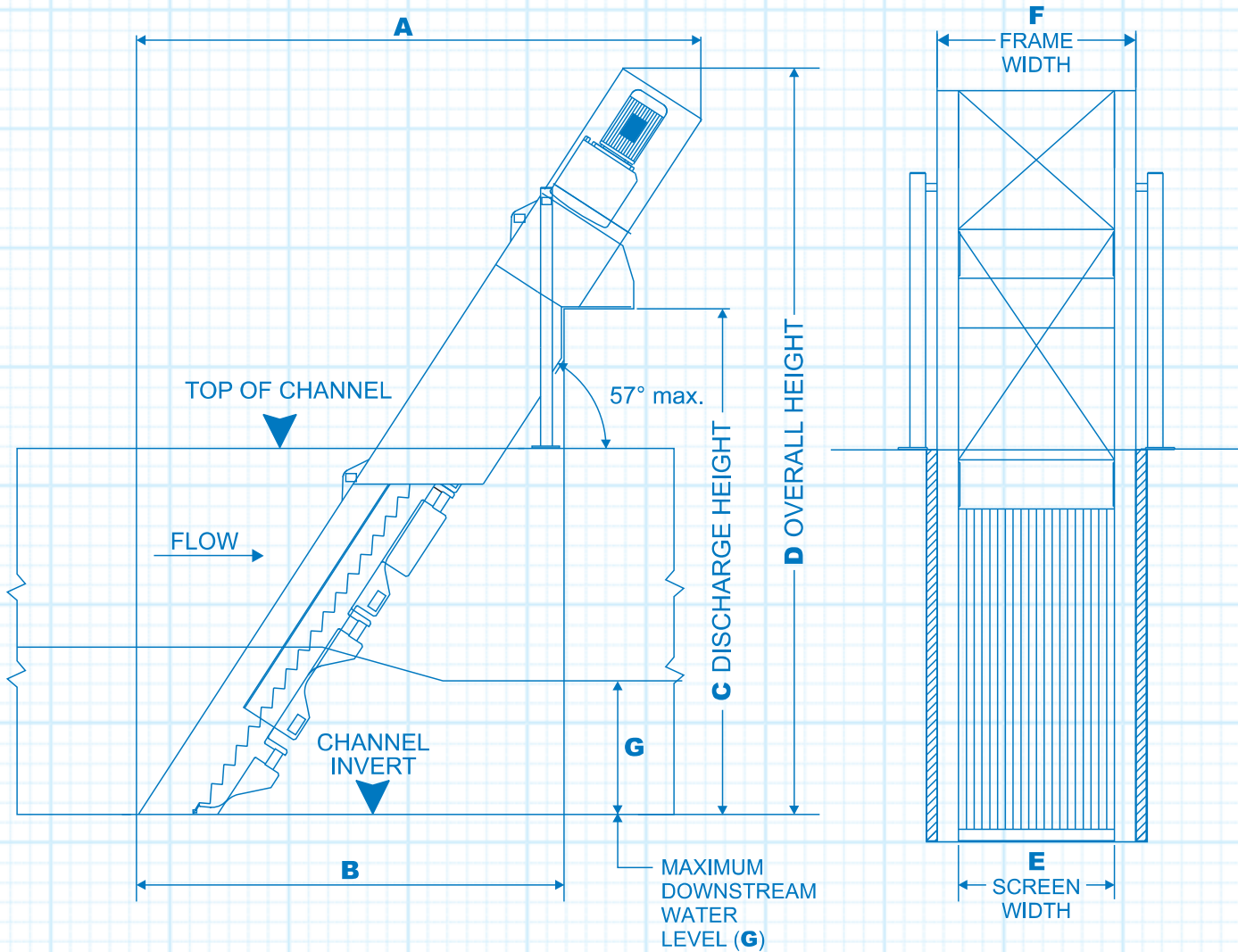

Type	A	B	C	D	E	F	G	Motor
ESR 13	6'-9"	4'-6"	4'-3"	8'-2"	12"—55"	19"—62"	1'-10"	1 HP
ESR 17	7'-7"	5'-4"	5'-6"	9'-5"	12"—55"	19"—62"	2'-9"	1—1.5 HP
ESR 23	8'-7"	6'-4"	7'	11'	14"—78"	23"—87"	3'-4"	2 HP
ESR 28	10'-3"	7'-8"	9'-1"	13'-6"	16"—78"	24"—87"	4'-7"	2—3 HP
ESR 34	11'-3"	8'-3"	10'-10"	15'-2"	16"—78"	24"—87"	5'-11"	3 HP
ESR 42	13'-3"	10'-8"	13'-9"	18'	18"—78"	30"—91"	5'-11"	5—7.5 HP

Find more product information at:
vulcanindustries.com

212 S. Kirlin Street
 Missouri Valley, Iowa 51555 USA
 712-642-2755 Fax 712-642-4256

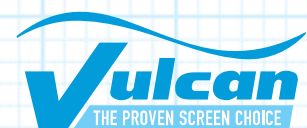

HUBER RakeMax® Multi-Rake Bar Screen



Reliable, sturdy travelling screen

- Very high screenings discharge capacity
- Low headloss
- Low installation height above ground level even in deep channels

►► Design and function

The HUBER RakeMax® Multi-Rake Bar Screen is perfectly suited to both municipal and industrial wastewater, and process water screening. The cleaning elements, attached to the chain system, can easily be adjusted to different requirements. These elements can be conventional rakes, or brushes, or plastic wipers.

As the cleaning elements are changeable, the screenings discharge capacity is then adjustable. This is especially favourable for high solids loads.

The installation height of the RakeMax® above ground level is very small and only dependent, even in case of deep channels, on the installation height of screenings transport or washing units.

Both ends of the cleaning elements are connected to drive chains. Each chain is driven by a sprocket on a common shaft and a flange mounted gear motor. Furthermore, defined meshing of the cleaning rakes with the bar rack ensures a high operating reliability. If the screen operation is blocked, a mechanical overload protection interrupts the operation.

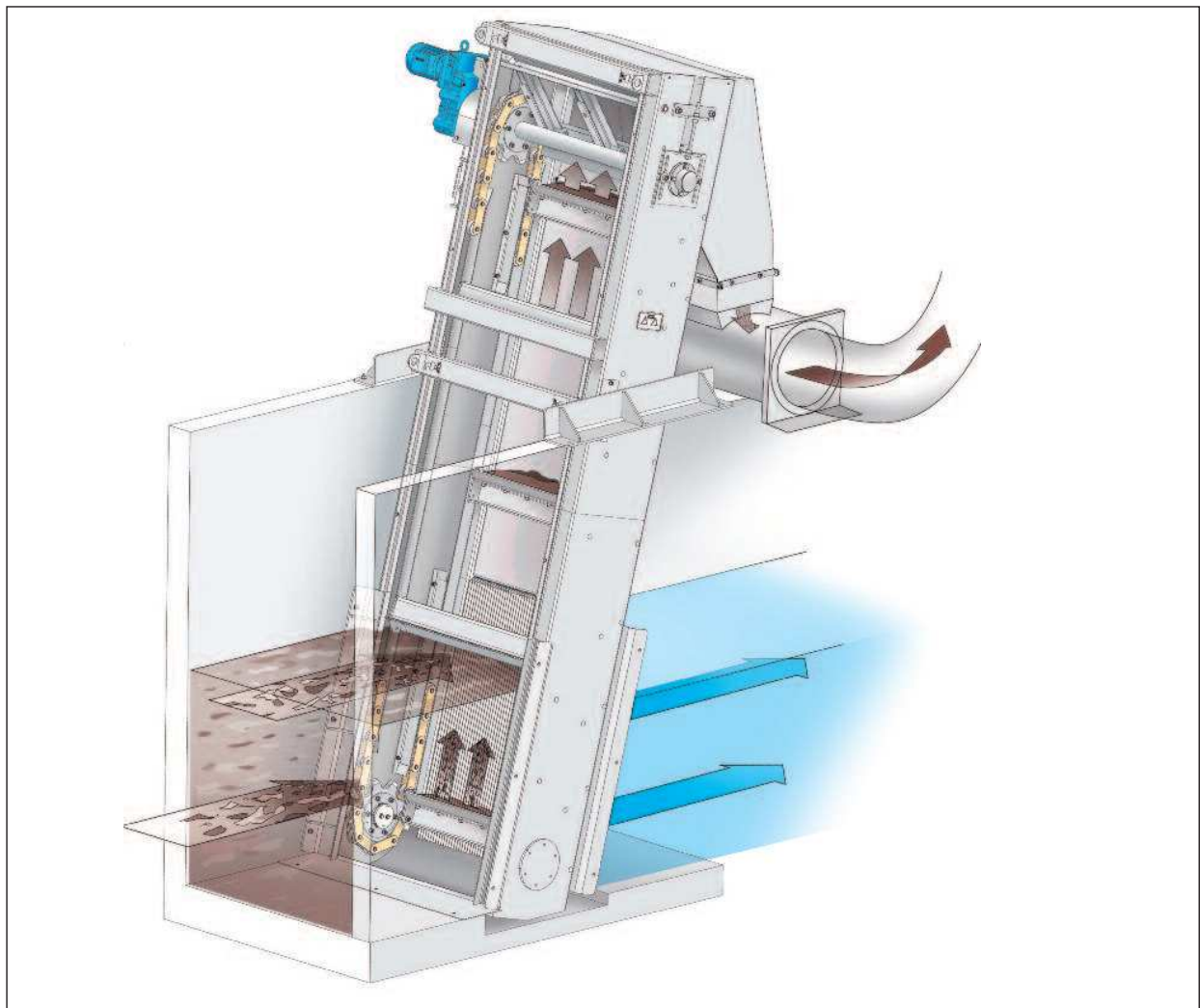

Schematic drawing of the HUBER RakeMax® Multi-Rake Bar Screen

►► The benefits of the RakeMax® Screen at a glance:

- Very low headloss – high separation efficiency
- Defined meshing of the cleaning rakes with the bar rack ensures a high operating reliability.
- Screen installation possible without a bottom step
- Compact design with a low installation height above ground level
- Completely odour-encased screen with easy to remove covers
- Easy-to-retrofit into existing channels, installation without channel recesses possible
- The screen consists of a self-supporting folded stainless steel profile so that it can easily be lifted out of the channel.
- Not hindered by gravel or grit
- Simple and easy-to-access chain tensioning unit
- All parts in contact with medium (except the chain, drive and bearing) are made of immersion pickled stainless steel, optional stainless steel chains.
- High screenings discharge capacity through adjustable cleaning elements
- Independently replaceable rake and comb plates

►► RakeMax® Features

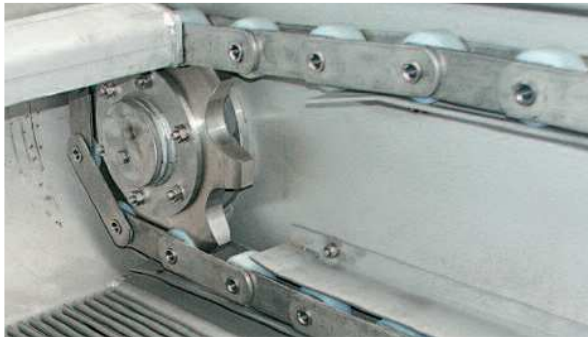

Drive chain made of hardened wear-resistant steel or stainless steel of different qualities as suitable for the specific requirements. Irrespective of the design, wear-resistant and maintenance-free ceramic bearings are used.

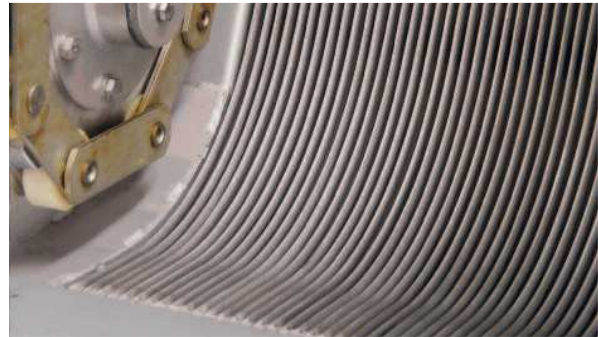

The RakeMax®-J offers extra high hydraulic throughput capacity and the advantage of screenings removal from the bar rack starting straight at the channel bottom, in addition to all the well known benefits of the proven RakeMax®, i.e. reliable solids separation and high screenings discharge capacity.



Screens with small bar spacings (here 6 mm) have specially shaped bars (tear drop design). The pressure loss is thus significantly reduced compared to flat or trapezoidal bars. The special bar shape prevents jamming of solids in the bar spacings. The screen proves thus its insensitivity to grit and gravel.



A control-independent safety system (torque compensator) reliably protects the screen against damage giving an electric signal. The specific design principle ensures high adjustability and continuous control.

►► Installation examples:



Universally applicable HUBER RakeMax® screen for big channel widths ...



... and big discharge heights

►► Screen sizes:

Channel width:	up to 4000 mm
Discharge height above channel floor:	up to 20 m
Bar spacing:	≥ 1 mm
Installation angle:	70° – 85°



Rear view of a HUBER RakeMax® Screen with subsequent Wash Press WAP/SL

HUBER SE

Industriepark Erasbach A1 · D-92334 Berching
Phone: + 49-84 62-201-0 · Fax: + 49-84 62-201-810
info@huber.de · Internet: www.huber.de

Subject to technical modification
0,15 / 11 – 5.2014 – 8.2004 - Vorabdruck IFAT 2014

HUBER RakeMax® Screen

STEP SCREEN® Flexible SSF



- for deep channels
- for high flows and low head loss
- for high screenings loads
- for lifting of screenings from the channel bottom
- for reliable operation and long life

➤➤ HUBER – The World Leader

With over 12,000 installations worldwide we are the unrivalled market leader as supplier of headwork equipment. No other screen supplier has comparable experience and expertise. We have thousands of STEP SCREEN® installations.

➤➤ The STEP SCREEN® System

The STEP SCREEN®, invented by HUBER-Hydropress, has been so successful because of its simple and self-cleansing function. STEP SCREENS® are not only highly efficient screens, but at the same time conveyors for gentle lifting and discharging of the screenings. They are suitable for deep channels; they handle high hydraulic and solids loads; and they are easy to operate and maintain.

➤➤ STEP SCREEN® Flexible – SSF

The SSF is installed in channels with an inclination between 40° and 53°. This variable inclination permits optimal adjustment to site conditions, such as channel depth and space constraints. Its discharge height is up to 11.5 ft (3.5 m) above the channel floor. The SSF has a linkage system with lubrication-free bearings, defining the exact and parallel movement of the lamellae over their entire

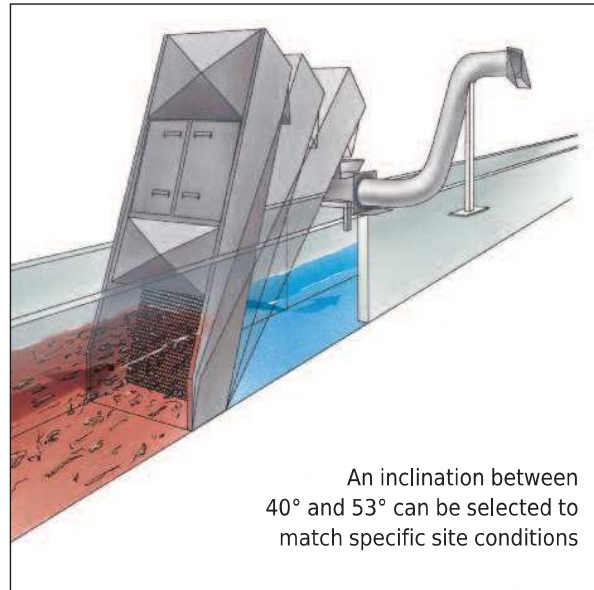

An inclination between 40° and 53° can be selected to match specific site conditions

length. Use of difficult-to-maintain chains and sprockets and water contamination by oil and grease is thus avoided.

➤➤ Operating principle

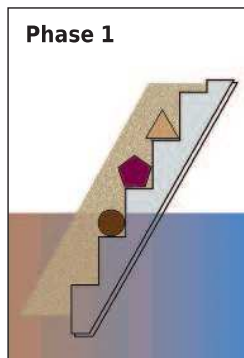

Screenings are retained on the steps and form a mat.

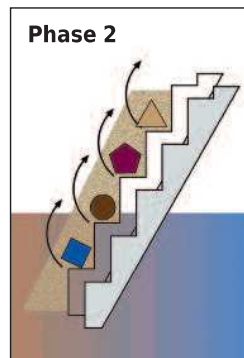

The complete screenings mat is lifted and transported, one step at a time, by rotation of the movable lamellae.

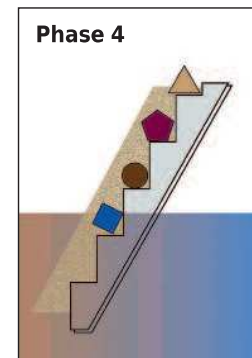
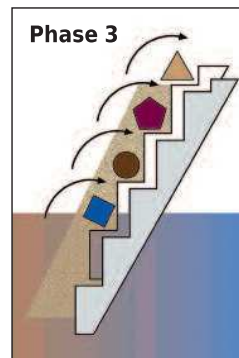

The screenings mat is laid down on the next step.

➤➤ Advantages of a screenings mat

The screenings mat or carpet forms a filter retaining particles that are smaller than the width of the spaces between the lamellae. The solids capture rate of the SSF

is thus further improved. The structure of the mat keeps the screenings together as they travel to the discharge point.

➤➤ SSF – HE Version

It has always been our main objective to reduce operation and maintenance work to a minimum, and to improve the reliability not only of our headworks equipment, but also of all downstream treatment processes.

The SSF-HE, when installed in channels without a bottom step or recess, has a vertical plate in front of the lowest step. Grit and gravel settles in front of this plate and should be removed from time to time. Installation of a bottom flap, as done by some competitors and intended for flushing grit and gravel through the bottom of the screen when opened, is no solution. Such flaps are hardly operable due to grit jamming. If they could be opened, coarse solids would be flushed through the open flap thus defeating the screen's purpose of protecting downstream equipment and processes from coarse and impairing material.

We have developed an optimal bottom step design for the SSF-HE screen preventing grit and gravel sedimentation and guaranteeing removal of rocks and gravel. The lowest step of the SSF-HE is flush with the channel floor. A horizontal plate extends from the channel floor to the edge of the first step, directing wastewater and solids onto the first step. The lowest step of the fixed lamellae is doubled up with stainless steel plates thus reducing its spacing. Gravel and rocks are thus retained on the lowest step. They are lifted up and removed when the lamellae rotate. Sedimentation in front of the screen is thus eliminated.

The SSF-HE is provided with a flush pipe for automatic and periodic flushing of grit that has settled underneath or behind the screen.

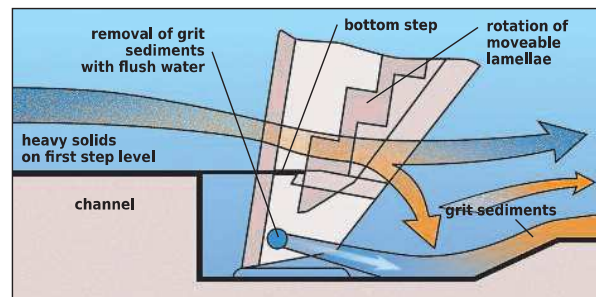
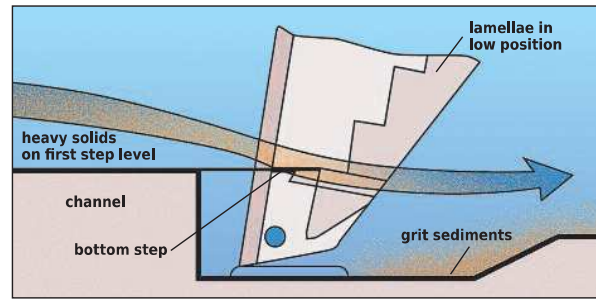

STEP SCREEN® with optimal bottom step design. The channel floor is flush with the top of the lowest step.

➤➤ SSF – HF Version

The SSF-HF does not have a vertical plate in front of its lowest step. It therefore has the largest open area, the highest flow capacity and the lowest head loss off all screens of this type.

While the movable lamellae rotate, they are removed from the lowest step for a short period of time. Edges of the movable lamellae engage the screenings and lift them to the next steps. The increased flow through the fixed lamellae flushes grit and gravel through the bottom of the screen. A flush pipe is not required.



Flexible 0.08" (2 mm) thick lamellae at the bottom of the SSF-HF

►► Benefits

Operational Principle

- Gentle and complete lifting of screenings and rocks from the channel floor

Variable Inclination

- Adjustable to site conditions

Outstanding Hydraulics

- Highest flow / lowest head loss of its class

Great Capture Rate

- High separation efficiency due to narrow slots, further improved by formation of screenings mat

Cleaning

- Self-cleansing design. No spray water or brushes are needed.

Odor Control

- Fully enclosed screen

Maintenance

- No need for regular lubrication

Reliability

- Low susceptibility to jamming by grit, gravel and rocks;
- Overload-protection with rocker arm and proximity switch

Durability

- Sturdy design
- Made of stainless steel, pickled in an acid bath

Experience

- Unsurpassed for more than 20 years; thousands of installations

►► Technical data

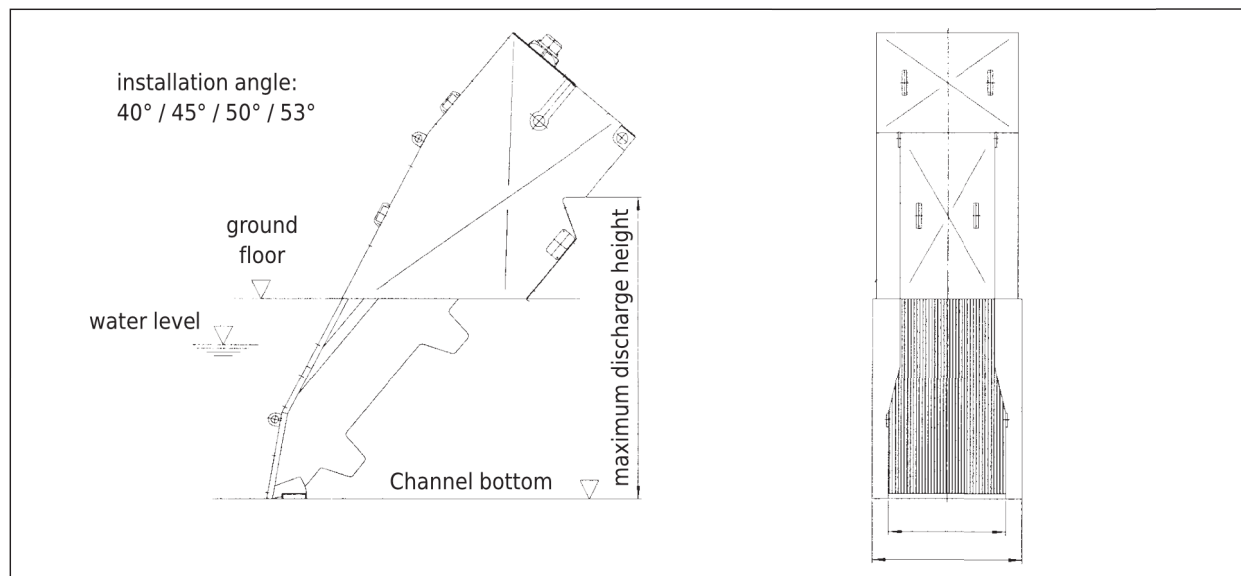

Flow: up to 60 MGD per unit
 Inclination: 40° to 53°
 Discharge height: max. 11.5' (3.5 m)
 Channel width: 20" to 6.5' (0.5 to 2 m)

Water level: max. 7.5' (2.3 m)
 Spacing: 1/8" or 1/4" (3 or 6 mm)
 Lamella thickness: 0.08" / 0.12" (2 / 3 mm)

HUBER TECHNOLOGY, Inc.

9735 NorthCross Center Court STE A · Huntersville, NC 28078
 Phone: (704) 949-1010 · Fax: (704) 949-1020
 huber@hhusa.net · <http://www.huber-technology.com>

Subject to technical modification
 0,0 / 9 – 11.2012 – 9.2004

STEP SCREEN® Flexible



Model EWP Washing Press

Product Information Guide

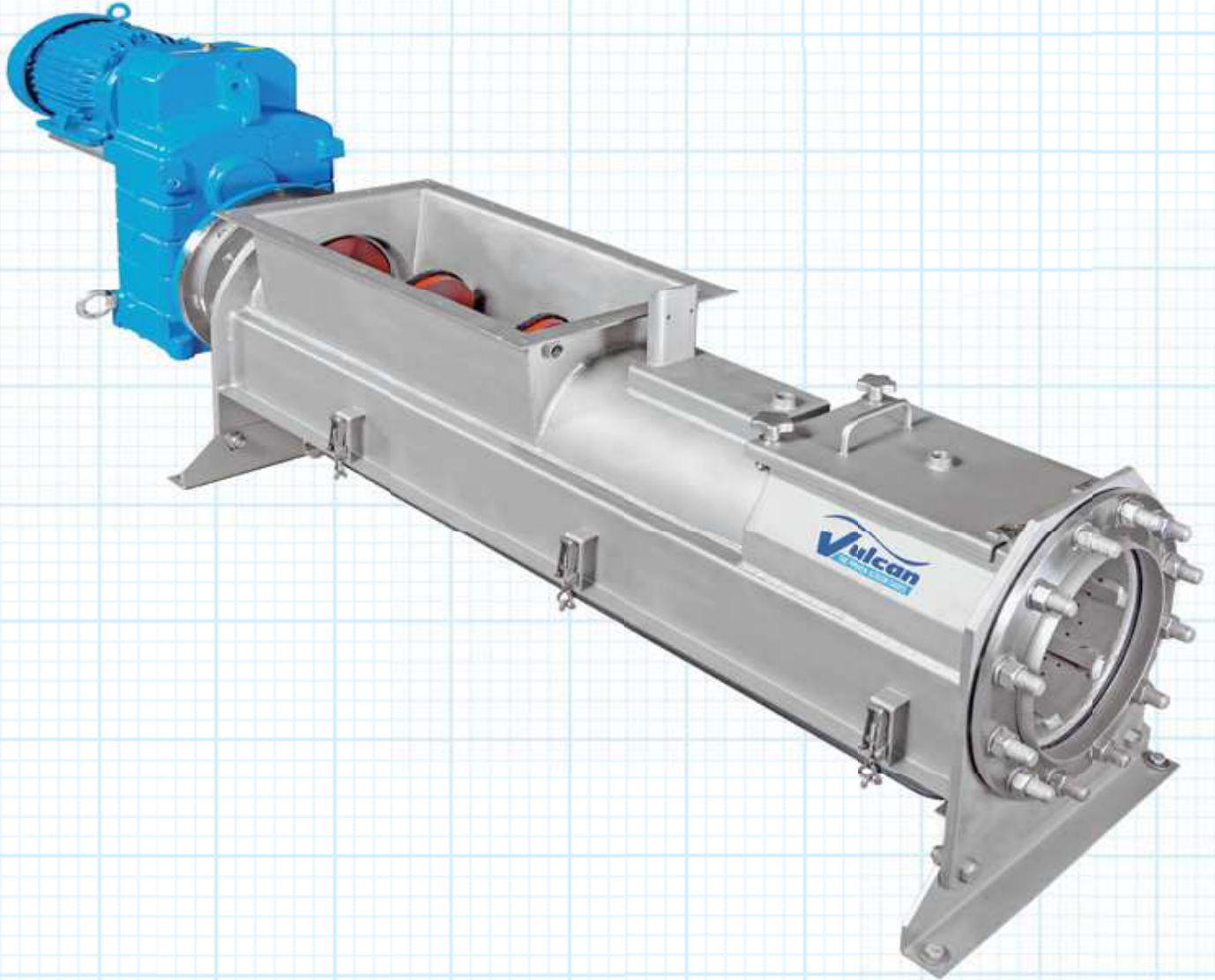

Find more product information at:
vulcanindustries.com

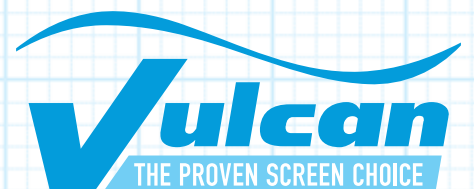



Model EWP Washing Press



A detail of the axial thrust bearing that connects the gear reducer to the press body and the shafted spiral. This bearing handles the load created during compaction and carries the overhung load of the spiral. This protects the gear reducer and extends the life of the unit.

The **Model EWP Washing Press** is a spiral press used to wash organic matter out of screenings material. The Washing Press washes, dewateres, compacts and transports screenings to a conveyor, container or other suitable receiving device.

Construction

The Washing Press consists of a press body with separate washing and dewatering sections, hollow shaft spiral, axial thrust bearing (see photo on left), gear reducer and motor, drain pan, washwater spray connections and sequencing valves.

The press body is constructed of stainless steel. A wedge wire drain constructed of individual profile bars is mounted on the bottom of the press and extends from the inlet hopper through the washing section. The wedge wire, with 2 mm spacings, guarantees clog-free drainage of the washwater, while ensuring screenings capture.

The spiral, of alloy steel construction, is welded to the hollow shaft. The hollow shaft contains perforations located in the washing zone to introduce washwater to the screenings from the inside out. A nylon brush is attached to the trailing edge of the spiral to ensure debris is thoroughly removed from the drainage area. The drain pan is constructed of stainless steel, and is located directly under the press body. A flushing nozzle periodically rinses the drain pan. Sealed with a gasket, and secured with a latching system, the drain pan is easily removed for service.



Model EWP Washing Press with an inlet hopper and discharge pipe. The inlet hopper can be directly connected to a primary screening device such as a Model FT Mensch Screen, Model VMR Multi-Rake Screen, or Model ESR Stair Screen, and can be fed by a conveyor or sluice trough. The discharge pipe can be fitted with a bagging assembly, or feed directly into a receiving container.



Note the substantial construction of the shafted spiral. A nylon brush is affixed to the trailing edge of the spiral to ensure the drain is clean, even when greasy material is present. Beneath the spiral you can see the wedgewire drain. The profiled bars (See section A-A on the diagram, right page) used in the drain construction allow for greater flow and prevent blinding. The spiral is cantilevered off the thrust bearing and does not rest in the housing. This reduces wear on the nylon brush and the press body by eliminating metal-to-metal contact.

Operation

The Washing Press receives the screenings from a primary screening device, sluice trough, or conveyor through the inlet hopper. The spiral transports the screenings from the inlet to the washing zone where they are compacted and washed. In the washing zone, washwater is injected into the screenings from the openings in the hollow shaft of the spiral, and from a nozzle at the top of the unit.

To maximize washing, after the press compacts the screenings the spiral reverses, pulling apart the compacted screenings. The cycle is repeated a minimum of four times, recompacting the screenings and squeezing out excess washwater and organics. The repetition helps the press achieve up to 90% organic removal from the screenings. As the screenings move into the dewatering zone, the pitch of the spiral decreases, further compacting the screenings for maximum water extraction prior to entering the discharge pipe. From inlet hopper to discharge, the screenings volume is reduced from 70% up to 85%.

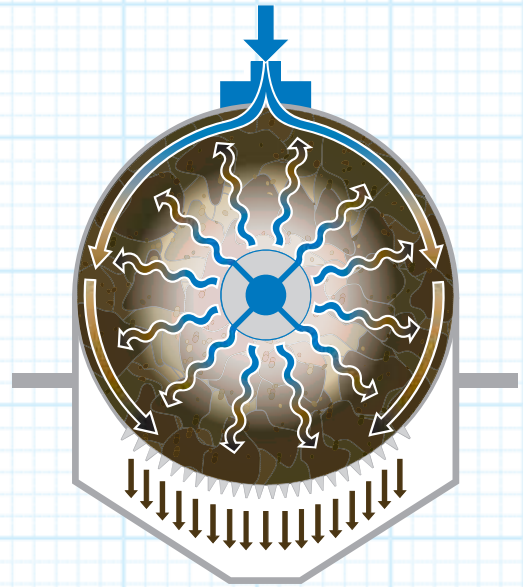

▲ Section A-A through the washing zone.

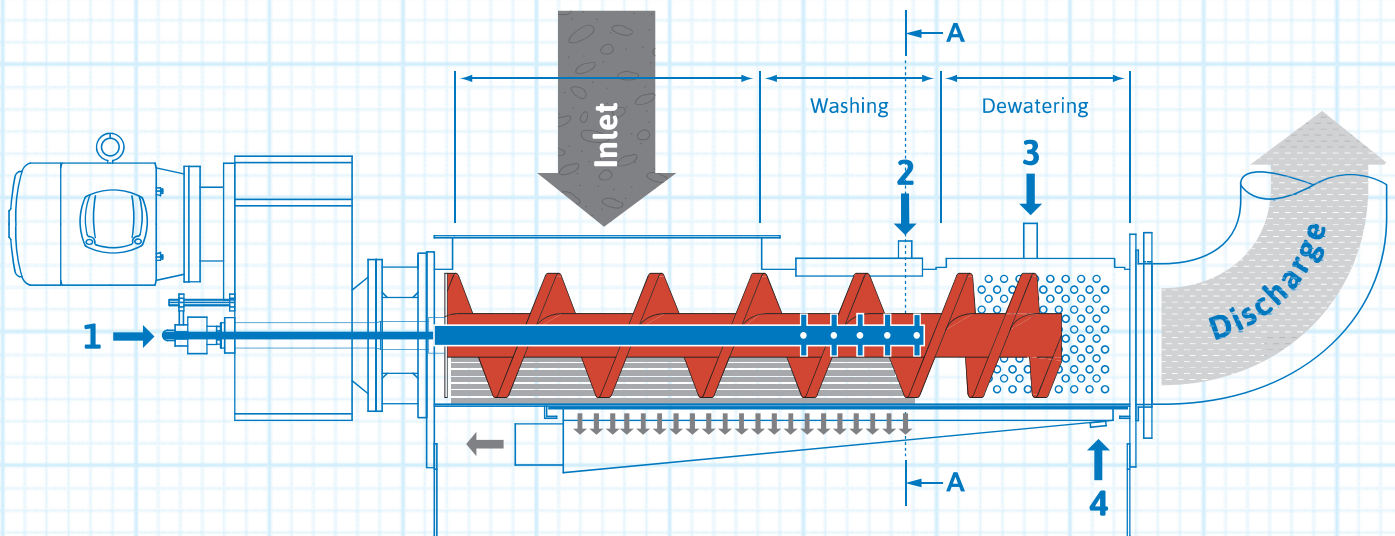

▲ Sequence of Valve Operations

- 1** Injects washwater into the washing zone through the hollow shaft spiral.
- 2** Injects washwater into the top of the washing zone.
- 3** Flushes dewatering zone.
- 4** Flushes drain pan.



Model EWP Washing Press

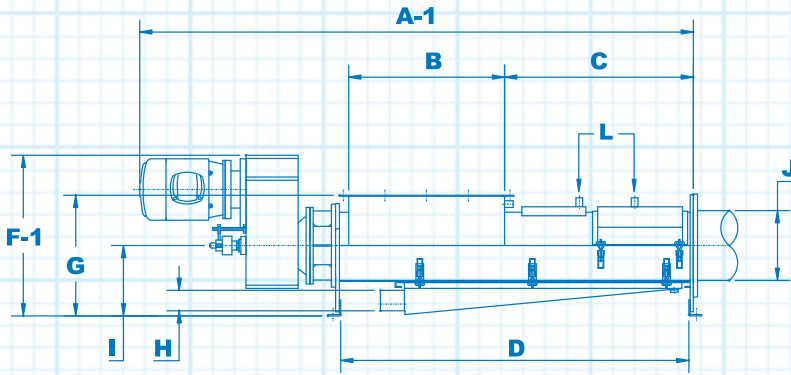
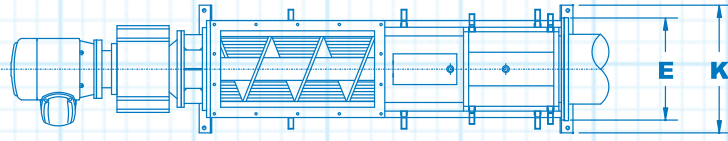

▲ Parallel Drive Configuration

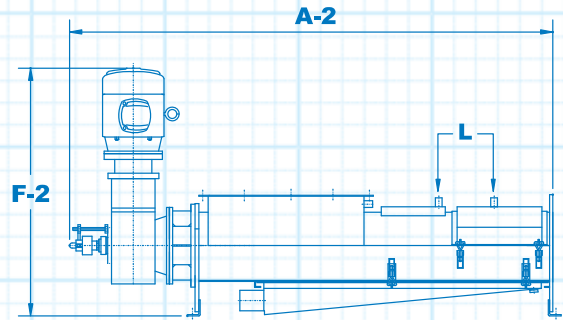

▲ Right Angle Drive Configuration

Type	A-1	A-2	B	C	D	E	F-1	F-2	G	H	I	J	K	L	MOTOR
EWP 250/600	86"	75"	24"x10"	29"	57"	16"	24"	40"	19"	3"	12"	10"ø	20"	1/2"	5 HP
EWP 250/800	94"	83"	32"x10"	29"	65"	16"	24"	40"	19"	3"	12"	10"ø	20"	1/2"	5 HP
EWP 250/1000	101"	91"	40"x10"	29"	73"	16"	24"	40"	19"	3"	12"	10"ø	20"	1/2"	5 HP
EWP 250/1200	109"	97"	48"x10"	29"	81"	16"	24"	40"	19"	3"	12"	10"ø	20"	1/2"	5 HP
EWP 250/1600	125"	113"	63"x10"	29"	92"	16"	24"	40"	19"	3"	12"	10"ø	20"	1/2"	5 HP
EWP 250/2000	141"	128"	78"x10"	29"	107"	16"	24"	40"	19"	3"	12"	10"ø	20"	1/2"	5 HP
EWP 300/600	98"	85"	24"x12"	34"	58"	19"	30"	50"	22"	4"	13"	12"ø	21"	3/4"	7.5 HP
EWP 300/800	106"	93"	32"x12"	34"	65"	19"	30"	50"	22"	4"	13"	12"ø	21"	3/4"	7.5 HP
EWP 300/1000	113"	100"	40"x12"	34"	73"	19"	30"	50"	22"	4"	13"	12"ø	21"	3/4"	7.5 HP
EWP 300/1200	122"	108"	48"x12"	34"	81"	19"	30"	50"	22"	4"	13"	12"ø	21"	3/4"	7.5 HP
EWP 300/1600	137"	124"	63"x12"	34"	96"	19"	30"	50"	22"	4"	13"	12"ø	21"	3/4"	7.5 HP
EWP 400/600	117"	98"	24"x16"	42"	70"	23.5"	39"	62"	27.5"	4"	14.5"	16"ø	26"	3/4"	10 HP
EWP 400/800	125"	106"	32"x16"	42"	78"	23.5"	39"	62"	27.5"	4"	14.5"	16"ø	26"	3/4"	10 HP
EWP 400/1000	132"	114"	40"x16"	42"	86"	23.5"	39"	62"	27.5"	4"	14.5"	16"ø	26"	3/4"	10 HP
EWP 400/1200	141"	122"	48"x16"	42"	94"	23.5"	39"	62"	27.5"	4"	14.5"	16"ø	26"	3/4"	10 HP

▼ Input Capacity of Raw Screenings

Type	Continuous Mode	Batch Mode
EWP 250	Up to 99 ft ³ /hr	Up to 33 ft ³ /hr
EWP 300	Up to 159 ft ³ /hr	Up to 53 ft ³ /hr
EWP 400	Up to 247 ft ³ /hr	Up to 82 ft ³ /hr

▼ Wash Water Requirements

Type	Requirements
EWP 250	19 gpm at 35 psi minimum – 60 psi maximum
EWP 300	27 gpm at 35 psi minimum – 60 psi maximum
EWP 400	27 gpm at 35 psi minimum – 60 psi maximum

Find more product information at:
vulcanindustries.com

212 S. Kirlin Street
 Missouri Valley, Iowa 51555 USA
 712-642-2755 Fax 712-642-4256

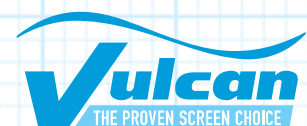

APPENDIX D
***Engineer's Opinion of Probable Construction
Cost***

SEWRF Preliminary Treatment Upgrades - Preliminary Design Report

THIS PAGE INTENTIONALLY LEFT BLANK

ENGINEER'S OPINION OF PROBABLE CONSTRUCTION COST
San Elijo Joint Powers Authority
SEWRF Preliminary Treatment Upgrades

PROJECT STATUS: Preliminary Design

ALTERNATIVE 1

Item	Total
General Items	\$ 115,000
Demolition (Outdoor)	\$ 38,000
Demolition (Inside Building)	\$ 40,000
Bypassing and Pipe Re-routing	\$ 162,000
- Re-route forcemains to new Inf. Junc. Chamber	\$ 32,000
- Re-route gravity line	\$ -
- Bypass pumping (cardiff gravity)	\$ 50,000
- Bypass pumping (grit effluent/primary inf chnl rehab)	\$ 80,000
- Bypass pumping (grit inlet channel bypassing)	\$ -
- Temporary odor control scrubber	\$ -
- Temporary odor control ducting	\$ -
- Full Headworks Bypassing w/ Temp Screenings	\$ -
Civil	\$ 12,000
Structural (New)	\$ 79,000
- Concrete Walls	\$ 27,520
- Concrete Slab	\$ 21,760
- Aluminum coverplates	\$ 12,773
- Canopy	\$ -
- Grit chamber covers	\$ 16,800
- New headworks building with temporary screening	\$ -
Structural (Rehab/Modify Existing)	\$ 137,000
Coatings	\$ 66,000
Equipment (Screenings)	\$ 899,000
- Multi-Rake Screens	\$ 520,520
- Wash presses	\$ 194,040
- Sluice (~50' long, diverter gate)	\$ 105,000
- Slide Gates	\$ 59,400
- Stop plates	\$ 19,800
- New Odor Control Scrubber	\$ -
Equipment (Relocated Outdoors)	\$ 40,000
Piping/Ducting	\$ 111,000
Electrical, Instrumentation & Control	\$ 335,000
- Conduit rework	\$ 70,000
- MCC modifications	\$ 75,000
- New Lighting	\$ 15,000
- New odor control LCP	\$ 100,000
- Install LCP and circuits	\$ 50,000
- Commissioning of LCP	\$ 25,000
Subtotal Construction Cost	\$ 2,034,000
Contingency on Subtotal (20%)	\$ 410,000
Bonds & Insurance (2.5%)	\$ 60,000
Subtotal	\$ 2,510,000
Bid Inflation Projection to Midpoint (3%)	\$ 80,000
Total Construction Cost	\$ 2,590,000

ENGINEER'S OPINION OF PROBABLE CONSTRUCTION COST
San Elijo Joint Powers Authority
SEWRF Preliminary Treatment Upgrades

PROJECT STATUS: Preliminary Design

ALTERNATIVE 2

Item	Total
General Items	\$ 115,000
Demolition (Outdoor)	\$ 35,000
Demolition (Inside Building)	\$ 40,000
Bypassing and Pipe Re-routing	\$ 175,000
- Re-route forcemains to new Inf. Junc. Chamber	\$ 40,000
- Re-route gravity line	\$ 5,000
- Bypass pumping (cardiff gravity)	\$ 50,000
- Bypass pumping (grit effluent/primary inf chnl rehab)	\$ 80,000
- Bypass pumping (grit inlet channel bypassing)	\$ -
- Temporary odor control scrubber	\$ -
- Temporary odor control ducting	\$ -
- Full Headworks Bypassing w/ Temp Screenings	\$ -
Civil	\$ 16,000
Structural (New)	\$ 114,000
- Concrete Walls	\$ 50,413
- Concrete Slab	\$ 29,360
- Aluminum coverplates	\$ 17,234
- Canopy	\$ -
- Grit chamber covers	\$ 16,800
- New headworks building with temporary screening	\$ -
Structural (Rehab/Modify Existing)	\$ 122,000
Coatings	\$ 66,000
Equipment (Screenings)	\$ 779,000
- Multi-Rake Screens	\$ 400,400
- Wash presses	\$ 194,040
- Sluice (~50' long, diverter gate)	\$ 105,000
- Slide Gates	\$ 59,400
- Stop plates	\$ 19,800
- New Odor Control Scrubber	\$ -
Equipment (Relocated Outdoors)	\$ 40,000
Piping/Ducting	\$ 111,000
Electrical, Instrumentation & Control	\$ 335,000
- Conduit rework	\$ 70,000
- MCC modifications	\$ 75,000
- New Lighting	\$ 15,000
- New odor control LCP	\$ 100,000
- Install LCP and circuits	\$ 50,000
- Commissioning of LCP	\$ 25,000
Subtotal Construction Cost	\$ 1,948,000
Contingency on Subtotal (20%)	\$ 390,000
Bonds & Insurance (2.5%)	\$ 50,000
Subtotal	\$ 2,390,000
Bid Inflation Projection to Midpoint (3%)	\$ 80,000
Total Construction Cost	\$ 2,470,000

ENGINEER'S OPINION OF PROBABLE CONSTRUCTION COST
San Elijo Joint Powers Authority
SEWRF Preliminary Treatment Upgrades

PROJECT STATUS: Preliminary Design

ALTERNATIVE 3

Item	Total
General Items	\$ 115,000
Demolition (Outdoor)	\$ 58,000
Demolition (Inside Building)	\$ 40,000
Bypassing and Pipe Re-routing	\$ 340,000
- Re-route forcemains to new Inf. Junc. Chamber	\$ 32,000
- Re-route gravity line	\$ -
- Bypass pumping (cardiff gravity)	\$ 50,000
- Bypass pumping (grit effluent/primary inf chnl rehab)	\$ 80,000
- Bypass pumping (grit inlet channel bypassing)	\$ 77,000
- Temporary odor control scrubber	\$ 81,000
- Temporary odor control ducting	\$ 20,000
- Full Headworks Bypassing w/ Temp Screenings	\$ -
Civil	\$ 15,000
Structural (New)	\$ 91,000
- Concrete Walls	\$ 34,400
- Concrete Slab	\$ 27,200
- Aluminum coverplates	\$ 12,766
- Canopy	\$ -
- Grit chamber covers	\$ 16,800
- New headworks building with temporary screening	\$ -
Structural (Rehab/Modify Existing)	\$ 137,000
Coatings	\$ 66,000
Equipment (Screenings)	\$ 899,000
- Multi-Rake Screens	\$ 520,520
- Wash presses	\$ 194,040
- Sluice (~50' long, diverter gate)	\$ 105,000
- Slide Gates	\$ 59,400
- Stop plates	\$ 19,800
- New Odor Control Scrubber	\$ -
Equipment (Relocated Outdoors)	\$ 40,000
Piping/Ducting	\$ 111,000
Electrical, Instrumentation & Control	\$ 335,000
- Conduit rework	\$ 70,000
- MCC modifications	\$ 75,000
- New Lighting	\$ 15,000
- New odor control LCP	\$ 100,000
- Install LCP and circuits	\$ 50,000
- Commissioning of LCP	\$ 25,000
Subtotal Construction Cost	\$ 2,247,000
Contingency on Subtotal (20%)	\$ 450,000
Bonds & Insurance (2.5%)	\$ 60,000
Subtotal	\$ 2,760,000
Bid Inflation Projection to Midpoint (3%)	\$ 90,000
Total Construction Cost	\$ 2,850,000

ENGINEER'S OPINION OF PROBABLE CONSTRUCTION COST**San Elijo Joint Powers Authority
SEWRF Preliminary Treatment Upgrades****PROJECT STATUS: Preliminary Design****ALTERNATIVE 4**

Item	Total
General Items	\$ 115,000
Demolition (Outdoor)	\$ 80,000
Demolition (Inside Building)	\$ 40,000
Bypassing and Pipe Re-routing	\$ 257,000
- Re-route forcemains to new Inf. Junc. Chamber	\$ 32,000
- Re-route gravity line	\$ -
- Bypass pumping (cardiff gravity)	\$ 50,000
- Bypass pumping (grit effluent/primary inf chnl rehab)	\$ 80,000
- Bypass pumping (grit inlet channel bypassing)	\$ -
- Temporary odor control scrubber	\$ -
- Temporary odor control ducting	\$ 20,000
- Full Headworks Bypassing w/ Temp Screenings	\$ 75,000
Civil	\$ 16,000
Structural (New)	\$ 139,000
- Concrete Walls	\$ 64,500
- Concrete Slab	\$ 40,800
- Aluminum coverplates	\$ 17,234
- Canopy	\$ -
- Grit chamber covers	\$ 16,800
- New headworks building with temporary screening	\$ -
Structural (Rehab/Modify Existing)	\$ 78,000
Coatings	\$ 50,000
Equipment (Screenings)	\$ 779,000
- Multi-Rake Screens	\$ 400,400
- Wash presses	\$ 194,040
- Sluice (~50' long, diverter gate)	\$ 105,000
- Slide Gates	\$ 59,400
- Stop plates	\$ 19,800
- New Odor Control Scrubber	\$ -
Equipment (Relocated Outdoors)	\$ 40,000
Piping/Ducting	\$ 100,000
Electrical, Instrumentation & Control	\$ 335,000
- Conduit rework	\$ 70,000
- MCC modifications	\$ 75,000
- New Lighting	\$ 15,000
- New odor control LCP	\$ 100,000
- Install LCP and circuits	\$ 50,000
- Commissioning of LCP	\$ 25,000
Subtotal Construction Cost	\$ 2,029,000
Contingency on Subtotal (20%)	\$ 410,000
Bonds & Insurance (2.5%)	\$ 60,000
Subtotal	\$ 2,500,000
Bid Inflation Projection to Midpoint (3%)	\$ 80,000
Total Construction Cost	\$ 2,580,000

ENGINEER'S OPINION OF PROBABLE CONSTRUCTION COST
San Elijo Joint Powers Authority
SEWRF Preliminary Treatment Upgrades

PROJECT STATUS: Preliminary Design

ALTERNATIVE 5

Item	Total
General Items	\$ 115,000
Demolition (Outdoor)	\$ 125,000
Demolition (Inside Building)	\$ 30,000
Bypassing and Pipe Re-routing	\$ 190,000
- Re-route forcemains to new Inf. Junc. Chamber	\$ 60,000
- Re-route gravity line	\$ -
- Bypass pumping (cardiff gravity)	\$ 50,000
- Bypass pumping (grit effluent/primary inf chnl rehab)	\$ 80,000
- Bypass pumping (grit inlet channel bypassing)	\$ -
- Temporary odor control scrubber	\$ -
- Temporary odor control ducting	\$ -
- Full Headworks Bypassing w/ Temp Screenings	\$ -
Civil	\$ 36,000
Structural (New)	\$ 1,092,000
- Concrete Walls	\$ 374,100
- Concrete Slab	\$ 74,800
- Aluminum coverplates	\$ 25,851
- Canopy	\$ -
- Grit chamber covers	\$ 16,800
- New headworks building with temporary screening	\$ 600,000
Structural (Rehab/Modify Existing)	\$ 82,000
Coatings	\$ 50,000
Equipment (Screenings)	\$ 1,139,000
- Multi-Rake Screens	\$ 400,400
- Wash presses	\$ 194,040
- Sluice (~50' long, diverter gate)	\$ 52,500
- Slide Gates	\$ 59,400
- Stop plates	\$ 19,800
- New Odor Control Scrubber	\$ 412,500
Equipment (Relocated Outdoors)	\$ -
Piping/Ducting	\$ 182,000
Electrical, Instrumentation & Control	\$ 335,000
- Conduit rework	\$ 70,000
- MCC modifications	\$ 75,000
- New Lighting	\$ 15,000
- New odor control LCP	\$ 100,000
- Install LCP and circuits	\$ 50,000
- Commissioning of LCP	\$ 25,000
Subtotal Construction Cost	\$ 3,376,000
Contingency on Subtotal (20%)	\$ 680,000
Bonds & Insurance (2.5%)	\$ 90,000
Subtotal	\$ 4,150,000
Bid Inflation Projection to Midpoint (3%)	\$ 130,000
Total Construction Cost	\$ 4,280,000

November 2, 2015

8981

Christopher A. Trees, PE
Director of Operations
San Elijo Joint Powers Authority
2695 Manchester Avenue
Cardiff-by-the-Sea, California 92007

Subject: Proposal for the Final Design of SEWRF Headworks Upgrade Project

Dear Mr. Trees:

We appreciate the opportunity to provide this scope and fee letter proposal for the final design of the Headworks Upgrade Project at the San Elijo Water Reclamation Facility (SEWRF). Dudek has been working closely with the SEJPA to develop the recommended project for upgrading the SEWRF's Headworks. The Final Preliminary Design Report prepared by Dudek for this project thoroughly evaluates multiple alternatives and outlines recommendations for the headworks layout, construction phasing to maintain plant operation, hydraulic design, screenings equipment selection, grit removal system, structural design, electrical design, and odor control system. We look forward to continuing with this project into the final design phase to prepare a quality bid set for construction which clearly defines the construction requirements and phasing to ensure a successful project. This letter proposal describes our project team, proposed scope of work, fee, and schedule.

Project Team

The same project team for the preliminary design would continue into the final design phase to ensure the project knowledge and quality is maintained. The project technical team and subconsultants have worked together on multiple final designs for headworks rehabilitation and retrofit projects. The key members of the project team include:

- Steve Deering, Principal-in-Charge / Technical Advisor
- Steve Jepsen, Project Manager
- Michael Hill, Lead Project Engineer
- Moraes-Pham & Associates, Electrical Engineer
- R2H Engineering, Structural Engineer
- Leighton Consulting, Geotechnical Engineer
- ROW Engineering, Survey

Scope of Work

The scope of work to provide professional engineering services for the final design of the SEWRF Headworks Upgrade Project is presented below.

Task 1 Project Management, Meetings, and QA/QC

Project Management

Our project team believes that communication with the project team members and the owner is of paramount importance. We encourage regular scheduled monthly meetings or calls with SEJPA to ensure timely exchange of information that will keep the project on schedule and budget. Our team is familiar with SEJPA staff and facilities. With Dudek's Encinitas office located only 5 minutes from the SEWRF, impromptu in-person meetings and site visits will be easily accommodated. We will prepare monthly project status reports to accompany our invoice that document work completed, budget status, schedule status and planned upcoming activities.

Meetings

We anticipate five (5) formal meetings with SEJPA through the course of final design. We anticipate we will meet with SEJPA staff for the kickoff meeting and after every submittal to review comments. Dudek will prepare meeting agendas and minutes for each meeting, which will be distributed to all attendees.

Quality Assurance and Quality Control

The Quality Control Manager, Steve Deering, will be engaged throughout the project, providing invaluable input from his extensive experience with the tributary collection system pump stations and SEWRF upgrades over the years. Mr. Deering will ensure the completion of quality control processes that will include review of specific project elements by appropriate senior staff. Additionally, the quality control reviewer(s) and project manager will collaborate on interdisciplinary reviews, checking of actual field conditions, project calculation reviews, cost opinions, deliverable review, unique project requirements, and successfully resolving and providing responses to SEJPA comments.

Task 2 Final Engineering and Contract Documents

Electrical Design

Moraes-Pham & Associates (MPA) will provide electrical, instrumentation, and control engineering design services. MPA will be responsible for all electrical, instrumentation, and control drawings and specifications. MPA will also provide bid phase services.

Structural Design

R2H Engineering will provide structural design engineering services. R2H will be responsible for all Structural drawings and specifications. R2H will also provide bid phase services.

Site Survey

ROW Engineering will perform field survey, field measurements of the existing structures, and revision of the existing topographic CAD file.

Geotechnical Investigation

Leighton Consulting will perform subsurface exploration, geotechnical laboratory testing services, geotechnical analysis, and geotechnical report preparation. Leighton will also provide review of the final design plans and specifications.

Contract Document Preparation

Dudek will perform final engineering design and preparation of the final drawings and technical specifications based on the recommendations based on the recommendations made in the Preliminary Design Report. It is assumed that Dudek will review the SEJPA prepared front end documents. The following will be submitted:

1. 30% Design
 - a. Half size drawings (3 copies)
 - b. Full size drawings (1 copy & PDF)
 - c. Technical Specification List (PDF)
 - d. Opinion of Probable Construction Cost
2. 60% Design
 - a. Half size drawings (3 copies)
 - b. Full size drawings (1 copy & PDF)
 - c. Draft Technical Specifications (PDF)
 - d. Opinion of Probable Construction Cost
3. 90% Design
 - a. Half size drawings (3 copies)
 - b. Full size drawings (1 copy & PDF)
 - c. Technical Specification List (3 copies & PDF)
 - d. Opinion of Probable Construction Cost
4. 100% Design
 - a. Half size drawings (3 copies)
 - b. Full size drawings (1 copy & PDF)
 - c. Technical Specification List (3 Copies & PDF)
 - d. Opinion of Probable Construction Cost
5. Final Signed
 - a. Half size drawings (3 copies)
 - b. Full size drawings (1 mylar, PDF, and DWG)
 - c. Technical Specification List (3 copies & PDF)
 - d. Opinion of Probable Construction Cost

The anticipated list of final drawings is attached.

Task 3 Bid Phase Services

It is anticipated that SEJPA will manage the construction bid process and be the designated primary point of contact for prospective bidders. It is also anticipated that SEJPA will administer the pre-bid meeting. Key personnel from the Dudek team will be in attendance.

Dudek will review and provide responses to bid phase requests for clarification (assume up to 6 RFCs). We will produce sketches or spec revisions, if required, to support issuance of addenda (assume up to 2 addenda) issued by SEJPA.

Schedule and Fee

We propose to complete the scope of work for a time and materials fee not to exceed \$263,522 as itemized in the attached work breakdown structure fee estimate. We will complete the work in accordance with the following schedule.

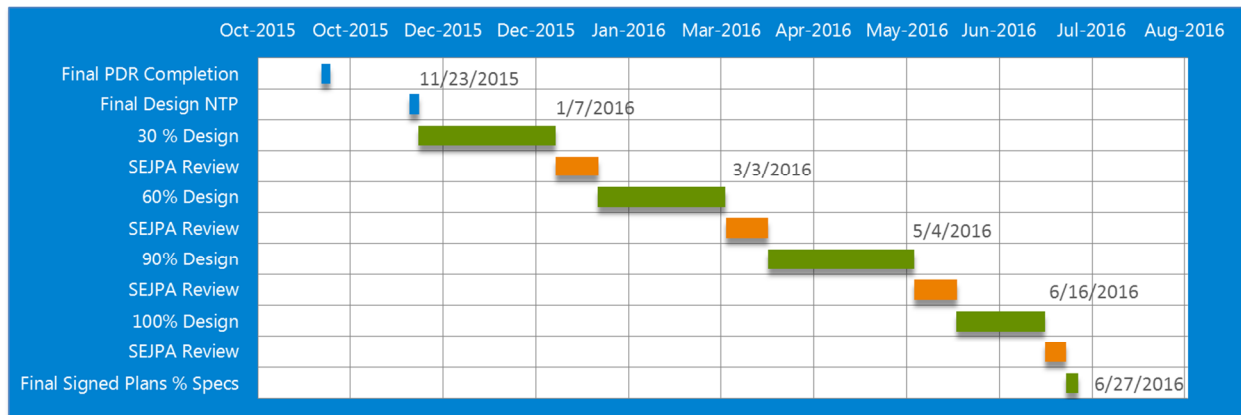

We appreciate the opportunity to provide SEJPA with the engineering services for Final Design of SEWRF Headworks Upgrade Project, and look forward to the notice to proceed. Please feel free to contact me at 760.479.4112 or by email at sjepsen@dudek.com, if there are any questions or if additional information is required.

Respectfully Submitted,
DUDEK

Steve Jepsen
Project Manager

Steve Deering, PE
Principal, Chief Engineer

Att: *Fee Estimate*
Drawing List
Rate Schedule

San Elijo Joint Powers Authority
San Elijo WRF Headworks Upgrade Project - Final Design
DUDEK FEE ESTIMATE
11/2/2015

	Project Team Role:	Project Team						TOTAL HOURS	DUDEK LABOR COST	Subconsultant Hours & Fees				OTHER DIRECT COSTS	TOTAL FEE	
		PIC QA/QC	Project Manager	Lead Engineer	Project Engineer	CAD Designer	CAD Drafter			Admin	Electrical & I/C Engineering Moraes-Pham & Associates	Structural Engineering R2H Engineering	Geotechnical Engineering Leighton Consulting			Survey ROW Engineering
		Team Member:	S. Deering	S. Jepsen	M. Hill	-	N. Hunter			-	-	Fee	Fee			Fee
Billable Rate :	\$225	\$195	\$155	\$120	\$140	\$110	\$80									
Task 1 - Proj.Mgt, Mtgs, QA/QC, Site Visit																
1-A	Kick off Meeting	2	4	4				10	\$ 1,850						\$ 1,850	
1-B	Progress Meetings (5)	6	10	12				28	\$ 5,160	\$1,173					\$ 6,333	
1-C	Project Administration		52	6				58	\$ 11,070						\$ 11,070	
1-D	QA/QC	28	8					36	\$ 7,860						\$ 7,860	
	Subtotal Task 1	36	74	22				132	\$ 25,940	\$ 1,173	\$ -	\$ -	\$ -	\$ -	\$ 27,113	
Task 2 - Construction Documents and Final Engineering																
2-A	Survey		1	1		2		4	\$ 630				\$3,657		\$ 4,287	
2-B	Geotechnical Investigation		1	2				3	\$ 505			\$11,270			\$ 11,775	
2-C	Site Visit		3	8		8		19	\$ 2,945	\$782					\$ 3,727	
2-C	Drawings	10	16	156	28	160	60	430	\$ 61,910	\$56,228	\$34,155	\$575			\$ 152,868	
2-D	Specifications	6	8	72	8			94	\$ 15,030	\$1,564	\$3,795	\$575			\$ 20,964	
2-E	Front End Documents	3	4	16				23	\$ 3,935						\$ 3,935	
2-F	Engineer's Opinion of Probable Construction Cost	3	8	32	8			51	\$ 8,155	\$2,392					\$ 10,547	
2-G	Final Engineering	10	12	64				86	\$ 14,510						\$ 14,510	
2-H	Deliverables (30%, 60%, 90%, pre-final, and final-signed)		6	20		14	6	20	\$ 8,490						\$ 8,490	
	Subtotal Task 2	32	59	371	44	184	66	776	\$ 116,110	\$ 60,966	\$ 37,950	\$ 12,420	\$ 3,657	\$ -	\$ 231,103	
Task 3 - Bid Phase Services																
3-A	Bidding Assistance		3	6				9	\$ 1,515	\$391	\$1,150				\$ 3,056	
3-B	Addenda		2	12				14	\$ 2,250						\$ 2,250	
	Subtotal Task 3		5	18				23	\$ 3,765	\$ 391	\$ 1,150	\$ -	\$ -	\$ -	\$ 5,306	
Total Non-Optional Hours and Fee		68	138	411	44	184	66	20	931	\$ 145,815	\$ 62,530	\$ 39,100	\$ 12,420	\$ 3,657	\$ -	\$ 263,522
<i>Percent of Hours:</i>		<i>7%</i>	<i>15%</i>	<i>44%</i>	<i>5%</i>	<i>20%</i>	<i>7%</i>	<i>2%</i>	<i>100%</i>							

Sheet	Dwg.	Title	Resp.
1	G-1	General - Title Sheet and Vicinity Map	Dudek
2	G-2	General - Notes and Drawing Index	Dudek
3	G-3	General - Abbreviations	Dudek
4	G-4	General - Symbols and Pipe Schedule	Dudek
5	G-5	General - Hydraulic Profile, Process Flow Diagram, and Design Criteria	Dudek
6	G-6	General - Overall Site Plan and Contractor Staging and Laydown	Dudek
7	D-1	Demolition - Site Plan	Dudek
8	D-2	Demolition - Screenings Equipment Plan	Dudek
9	D-3	Demolition - Grit and Screenings Building Plan	Dudek
10	GC-1	Civil - Details and Notes	Dudek
11	C-1	Civil - Site Plan	Dudek
12	GS-1	Structural - General Notes	R2H
13	GS-2	Structural - General and Typical Details	R2H
14	GS-3	Structural - Typical Details	R2H
15	S-1	Structural - Screenings Channels Plan	R2H
16	S-2	Structural - Screenings Channels Sections	R2H
17	S-3	Structural - Screenings Channels Sections	R2H
18	S-4	Structural - Grit Chamber and Channels Plan	R2H
19	S-5	Structural - Grit Chamber and Channels Sections	R2H
20	S-6	Structural - Meter Vault Plan and Sections	R2H
21	S-7	Structural - Headworks Sections and Details	R2H
22	S-8	Structural - Headworks Details	R2H
23	S-9	Structural - Headworks Details	R2H
24	GM-1	Mechanical - Notes, Equipment Schedules, and Standard Details	Dudek
25	GM-2	Mechanical - Standard Details 1	Dudek
26	GM-3	Mechanical - Standard Details 2	Dudek
27	M-1	Mechanical - Headworks Key Plan	Dudek
28	M-2	Mechanical - Influent Forcemains and Vaults Plan and Sections	Dudek
29	M-3	Mechanical - Screenings Channels and Equipment Plan	Dudek
30	M-4	Mechanical - Screenings Channels and Equipment Sections	Dudek
31	M-5	Mechanical - Screenings Channels and Equipment Sections and Details	Dudek
32	M-6	Mechanical - Grit and Screenings Building Plan	Dudek
33	M-7	Mechanical - Grit and Screenings Building Sections	Dudek
34	M-8	Mechanical - Grit and Screenings Building Sections and Details	Dudek
35	M-9	Mechanical - Foul Air Ducting Plan	Dudek
36	M-10	Mechanical - Grit Aeration Piping Plans	Dudek
37	M-11	Mechanical - Grit Aeration Piping Sections and Details	Dudek
38	GE-1	Electrical - Standard Symbols and Abbreviations	MPA
39	E-1	Electrical - Site Plan	MPA

Sheet	Dwg.	Title	Resp.
40	E-2	Electrical - Single Line Diagram	MPA
41	E-3	Electrical - Schedules	MPA
42	E-4	Electrical - Controls 1	MPA
43	E-5	Electrical - Controls 2	MPA
44	E-6	Electrical - Odor Control LCP	MPA
45	E-7	Electrical - Canopy Area Area Plan	MPA
46	E-8	Electrical - Headworks Area Plan	MPA
47	E-9	Electrical - Screenings Building Power & Signal Plan	MPA
48	E-10	Electrical - Screenings Building Lighting Plan	MPA
49	E-11	Electrical - MCC Building Plan/Elevations	MPA
50	E-12	Electrical - Headworks Demo Plan	MPA
51	E-13	Electrical - Screening Building Demo Plan	MPA
52	E-14	Electrical - Details/Photos 1	MPA
53	E-15	Electrical - Details/Photos 2	MPA
54	GI-1	Process and Instrumentation - Symbols and Abbreviations	MPA
55	I-1	Process and Instrumentation - Diagram 1	MPA
56	I-2	Process and Instrumentation - Diagram 2	MPA
57	I-3	Process and Instrumentation - Diagram 3	MPA

DUDEK
2015 STANDARD SCHEDULE OF CHARGES

ENGINEERING SERVICES

Project Director.....	\$255.00/hr
Principal Engineer III.....	\$225.00/hr
Principal Engineer II.....	\$215.00/hr
Principal Engineer I.....	\$205.00/hr
Program Manager.....	\$205.00/hr
Senior Project Manager.....	\$195.00/hr
Project Manager.....	\$190.00/hr
Senior Engineer III.....	\$185.00/hr
Senior Engineer II.....	\$175.00/hr
Senior Engineer I.....	\$165.00/hr
Project Engineer IV/Technician IV.....	\$155.00/hr
Project Engineer III/Technician III.....	\$140.00/hr
Project Engineer II/Technician II.....	\$125.00/hr
Project Engineer I/Technician I.....	\$110.00/hr
Project Coordinator.....	\$85.00/hr
Engineering Assistant.....	\$75.00/hr

ENVIRONMENTAL SERVICES

Principal.....	\$235.00/hr
Senior Project Manager/Specialist II.....	\$220.00/hr
Senior Project Manager/Specialist I.....	\$210.00/hr
Environmental Specialist/Planner VI.....	\$190.00/hr
Environmental Specialist/Planner V.....	\$170.00/hr
Environmental Specialist/Planner IV.....	\$160.00/hr
Environmental Specialist/Planner III.....	\$150.00/hr
Environmental Specialist/Planner II.....	\$130.00/hr
Environmental Specialist/Planner I.....	\$120.00/hr
Analyst III.....	\$110.00/hr
Analyst II.....	\$100.00/hr
Analyst I.....	\$90.00/hr
Planning Assistant II.....	\$80.00/hr
Planning Assistant I.....	\$70.00/hr

COASTAL PLANNING/POLICY SERVICES

Senior Project Manager/Coastal Planner II.....	\$215.00/hr
Senior Project Manager/Coastal Planner I.....	\$205.00/hr
Environmental Specialist/Coastal Planner VI.....	\$195.00/hr
Environmental Specialist/Coastal Planner V.....	\$175.00/hr
Environmental Specialist/Coastal Planner IV.....	\$165.00/hr
Environmental Specialist/Coastal Planner III.....	\$155.00/hr
Environmental Specialist/Coastal Planner II.....	\$145.00/hr
Environmental Specialist/Coastal Planner I.....	\$135.00/hr

ARCHAEOLOGICAL SERVICES

Senior Project Manager/Archaeologist II.....	\$210.00/hr
Senior Project Manager/Archaeologist I.....	\$200.00/hr
Environmental Specialist/Archaeologist VI.....	\$180.00/hr
Environmental Specialist/Archaeologist V.....	\$160.00/hr
Environmental Specialist/Archaeologist IV.....	\$150.00/hr
Environmental Specialist/Archaeologist III.....	\$140.00/hr
Environmental Specialist/Archaeologist II.....	\$130.00/hr
Environmental Specialist/Archaeologist I.....	\$120.00/hr
Environmental Specialist/Paleontologist III.....	\$160.00/hr
Environmental Specialist/Paleontologist II.....	\$140.00/hr
Environmental Specialist/Paleontologist I.....	\$120.00/hr
Paleontological Technician III.....	\$80.00/hr
Paleontological Technician II.....	\$70.00/hr
Paleontological Technician I.....	\$50.00/hr
Archaeologist Technician II.....	\$70.00/hr
Archaeologist Technician I.....	\$50.00/hr

CONSTRUCTION MANAGEMENT SERVICES

Principal/Manager.....	\$195.00/hr
Senior Construction Manager.....	\$180.00/hr
Senior Project Manager.....	\$160.00/hr
Construction Manager.....	\$150.00/hr
Project Manager.....	\$140.00/hr
Resident Engineer.....	\$140.00/hr
Construction Engineer.....	\$135.00/hr
On-site Owner's Representative.....	\$130.00/hr
Construction Inspector III.....	\$125.00/hr
Construction Inspector II.....	\$115.00/hr
Construction Inspector I.....	\$105.00/hr
Prevailing Wage Inspector.....	\$135.00/hr

COMPLIANCE SERVICES

Compliance Director.....	\$200.00/hr
Compliance Manager.....	\$140.00/hr
Compliance Project Coordinator.....	\$100.00/hr
Compliance Monitor.....	\$90.00/hr

HYDROGEOLOGICAL SERVICES

Principal.....	\$235.00/hr
Sr. Hydrogeologist IV/Engineer IV.....	\$215.00/hr
Sr. Hydrogeologist III/Engineer III.....	\$200.00/hr
Sr. Hydrogeologist II/Engineer II.....	\$180.00/hr
Sr. Hydrogeologist I/Engineer I.....	\$165.00/hr
Hydrogeologist VI/Engineer VI.....	\$150.00/hr
Hydrogeologist V/Engineer V.....	\$140.00/hr
Hydrogeologist IV/Engineer IV.....	\$130.00/hr
Hydrogeologist III/Engineer III.....	\$120.00/hr
Hydrogeologist II/Engineer II.....	\$110.00/hr
Hydrogeologist I/Engineer I.....	\$100.00/hr
Technician.....	\$95.00/hr

DISTRICT MANAGEMENT & OPERATIONS

District General Manager.....	\$175.00/hr
District Engineer.....	\$160.00/hr
Operations Manager.....	\$150.00/hr
District Secretary/Accountant.....	\$85.00/hr
Collections System Manager.....	\$95.00/hr
Grade V Operator.....	\$100.00/hr
Grade IV Operator.....	\$85.00/hr
Grade III Operator.....	\$80.00/hr
Grade II Operator.....	\$63.00/hr
Grade I Operator.....	\$55.00/hr
Operator in Training.....	\$40.00/hr
Collection Maintenance Worker II.....	\$55.00/hr
Collection Maintenance Worker I.....	\$40.00/hr

OFFICE SERVICES

Technical/Drafting/CADD Services

3D Graphic Artist.....	\$150.00/hr
Senior Designer.....	\$140.00/hr
Designer.....	\$130.00/hr
Assistant Designer.....	\$125.00/hr
GIS Specialist IV.....	\$150.00/hr
GIS Specialist III.....	\$140.00/hr
GIS Specialist II.....	\$130.00/hr
GIS Specialist I.....	\$120.00/hr
CADD Operator III.....	\$120.00/hr
CADD Operator II.....	\$115.00/hr
CADD Operator I.....	\$100.00/hr
CADD Drafter.....	\$90.00/hr
CADD Technician.....	\$80.00/hr

SUPPORT SERVICES

Technical Editor III.....	\$140.00/hr
Technical Editor II.....	\$125.00/hr
Technical Editor I.....	\$110.00/hr
Publications Specialist III.....	\$100.00/hr
Publications Specialist II.....	\$90.00/hr
Publications Specialist I.....	\$80.00/hr
Clerical Administration II.....	\$80.00/hr
Clerical Administration I.....	\$75.00/hr

Forensic Engineering – Court appearances, depositions, and interrogatories as expert witness will be billed at 2.00 times normal rates.

Emergency and Holidays – Minimum charge of two hours will be billed at 1.75 times the normal rate.

Material and Outside Services – Subcontractors, rental of special equipment, special reproductions and blueprinting, outside data processing and computer services, etc., are charged at 1.15 times the direct cost.

Travel Expenses – Mileage at current IRS allowable rates. Per diem where overnight stay is involved is charged at cost

Invoices, Late Charges. – All fees will be billed to Client monthly and shall be due and payable upon receipt. Invoices are delinquent if not paid within thirty (30) days from the date of the invoice. Client agrees to pay a monthly late charge equal to one percent (1%) per month of the outstanding balance until paid in full.

Annual Increases – Unless identified otherwise, these standard rates will increase 3% annually.

SAN ELIJO JOINT POWERS AUTHORITY
MEMORANDUM

November 9, 2015

TO: Board of Directors
San Elijo Joint Powers Authority

FROM: General Manager

SUBJECT: VILLAGE PARK RECYCLED WATER PROJECT UPDATE

RECOMMENDATION

No action required. This memorandum is submitted for information only.

BACKGROUND

At the October 2013 SEJPA Board meeting, the General Manager presented opportunities for expanding recycled water deliveries. The staff report highlighted several projects that could be developed in partnership with the local water districts. The General Manager provided the Board a letter-of-intent for expanding recycled water sales to both Olivenhain Municipal Water District (OMWD) and Santa Fe Irrigation District (SFID). The Board of Directors provided direction to the General Manager to move forward with developing the project concepts.

At the July 2014 SEJPA Board meeting, the General Manager recommended partnering with OMWD to expand recycled water service to the Village Park community located in the City of Encinitas. The Board approved the agreements for delivering recycled water to the project and for sharing capital costs.

The Village Park project includes more than 7 miles of new recycled water pipelines, the conversion of an existing potable water reservoir to recycled water storage, and the construction of a new water pressure boosting station. The project will provide recycled water for landscape irrigation for streetscape, greenbelts, and several schools. The recycled water for this project will be produced at the San Elijo Water Reclamation Facility. It is anticipated that the project will ultimately conserve 90 million gallons of potable water per year by converting existing irrigation systems to recycled water.

DISCUSSION

Staff will provide a PowerPoint Presentation to update the Board on project progress.

Respectfully submitted,



Michael T. Thornton, P.E.
General Manager